

Vickers by Danfoss Power Amplifier

105EC00044A, EEA-PAM-535-D-33

www: www.salushydraulics.pl
e-mail: pl@salushydraulics.pl
shop/sklep: www.salushydraulics.pl/sklep/



ENGINEERING
TOMORROW

BC444273273086en-000101

DISCLAIMER OF WARRANTIES AND LIMITATION OF LIABILITY

The information, recommendations, descriptions and safety notations in this document are based on Danfoss experience and judgment and may not cover all contingencies. If further information is required, a Danfoss sales office should be consulted. Sale of the product shown in this literature is subject to the terms and conditions outlined in appropriate Danfoss selling policies or other contractual agreement between Danfoss and the purchaser.

THERE ARE NO UNDERSTANDINGS, AGREEMENTS, WARRANTIES, EXPRESSED OR IMPLIED, INCLUDING WARRANTIES OF FITNESS FOR A PARTICULAR PURPOSE OR MERCHANTABILITY, OTHER THAN THOSE SPECIFICALLY SET OUT IN ANY EXISTING CONTRACT BETWEEN THE PARTIES. ANY SUCH CONTRACT STATES THE ENTIRE OBLIGATION OF DANFOSS. THE CONTENTS OF THIS DOCUMENT SHALL NOT BECOME PART OF OR MODIFY ANY CONTRACT BETWEEN THE PARTIES.

In no event will Danfoss be responsible to the purchaser or user in contract, in tort (including negligence), strict liability or otherwise for any special, indirect, incidental or consequential damage or loss whatsoever, including but not limited to damage or loss of use of equipment, plant or power system, cost of capital, loss of power, additional expenses in the use of existing power facilities, or claims against the purchaser or user by its customers resulting from the use of the information, recommendations and descriptions contained herein. The information contained in this manual is subject to change without notice.

Contents

Index

General installation recommendation	4
General description	5
Features	5
Type A amplifier for proportional control valves	6
Type B amplifier with command logic	16
Type C amplifier with command logic module and 4 ramps..... Module and 2 ramps	22
Type D Power amplifiers with PID modules	31
Type E power amplifiers with strip guidance controller modules.....	40
Type F Power amplifiers with CNC adaptation modules	49
EURO PAM card offerings	58

General installation recommendation

The amplifier is ready for use as supplied, but it must be properly installed by a qualified person using the machine designer's wiring diagram

1. Safety notes

1. The amplifiers described in these installation and start-up guidelines are designed exclusively for electrical control of the corresponding Danfoss proportional valves specified.
2. Start-up, maintenance and repair operations may only be performed by qualified personnel with knowledge of electrics/electronics.
3. The 24V DC supply voltage must meet the guidelines for safe low voltages according to VDE 0551/EN 607242/IEC 742.

2. Pre-installation checks

1. Check for any damage received in transit.
2. Ensure that the model code on this amplifier is the correct one for the application.
3. Check that the 24V DC power supply is within the specification.
4. Ensure that no adjustments are made before the amplifier is installed and powered up.
5. Ensure that the power is switched OFF before installing it into its edge connector. (Never insert or remove the amplifier while the electronic system is live.)

3. Installation requirements according to European EMC regulations

1. Use screened cables for the wires between amplifier and solenoid. The screen must be connected to protective ground at the amplifier end.
2. The amplifier board must be mounted in a metal housing which is connected to an efficient ground point.
3. The wiring for the LVDT (if fitted) must be screened and grounded at both ends to efficient ground points.

Alternatively, double screened cable can be used for the LVDT with the two screens grounded at opposite ends.

Table 1.

EMC		
Radiated Emission	CISPR 11:2015	Class A: 30MHz to 1 GHz
Radiated Immunity	IEC 61000-4-3:2010	Class A: 80MHz to 2.7 GHz: 10V/m
Conducted Emissions	CISPR 11:2015	Class A: 150kHz to 30MHz
Conducted immunity	IEC 61000-4-6:2008 DC Port: 3Vrms Signal Port: 3Vrms	Class A: 150kHz to 80 MHz
Electric fast Transient immunity	IEC 61000-4-4:2012 DC Port: ±2kV Signal Port: ±1kV	Class B
Surge Immunity Test	IEC 61000-4-5:2014 DC Port: ±1kV Signal Port: ±0.5kV	Class B
Electrostatic discharge (ESD)	IEC 61000-4-2:2008 Air: ±8kV Contact: ±4kV	Class B

WARNING

Electromagnetic Compatibility (EMC)

It is necessary to ensure that the unit is wired up in accordance with the connection arrangements shown in this catalog. For effective protection, the user's electrical cabinet, the valve subplate or manifold and the cable screens should be connected to efficient earth (ground) points. In all cases, both valve and cable should be kept as far away as possible from any source of electromagnetic radiation such as cables carrying heavy current, relays and certain kinds of portable radio transmitters, etc. Difficult environments could mean that extra screening may be necessary to avoid the interference.

Type A amplifier for proportional control valves

General description

The power amplifier has five voltage inputs (one inverting) and a current input 0-20 mA. Adjustments for set zero point or deadband compensation and for gain allow the amplifier to be easily tuned to the proportional control valve. The ramp function generator can be switched on and off using the "ramp enable" control.

Monitor points on the front panel allow measurement of the conditioned command signal, and either of spool position LVDT signal or (for valves without LVDT) of solenoid current. ("Conditioned command signal" is the input signal modified according to settings of set zero point or deadband compensation, gain and ramp functions.)

Features

- User-friendly front panel with all the necessary adjustments, LEDs and monitor points
- Electronic overload protection with automatic reset
- Pulse width modulation for high efficiency
- Can be equipped with plug-in modules for special functions
- Switchable ramp function generator for controlling rates of increase and decrease of output
- 24V DC power supply
- Either current or voltage input signals
- Standard input and output signals
- CE Electromagnetic compatibility.- 2014/30/EU
- RoHS Compatibility-DIRECTIVE 2011/65/EU



This product has been designed and tested to meet specific standards outlined in the European Electromagnetic Compatibility Directive (EMC) 2014/30/EU which repealed Directive 89/336/EEC, amended by Directives 91/263/EEC, 92/31/EEC, 93/68/EEC and 93/97/EEC. For instructions on installation requirements to achieve effective protection levels, see the Installation Wiring Practices for Vickers Electronic Products leaflet 2468. Wiring practices relevant to this Directive are indicated by  Electromagnetic Compatibility (EMC).

Type A Amplifier for proportional control valves

The following power amplifier models are covered in this catalog

Table 2.

Power amplifier	For proportional valve
EEA-PAM-513-A-33	KCG-3, 1* series KCG-6/8, 1* series KX(C)G-6/8, 1* series
EEA-PAM-523-A-33	KTG4V-3...H*, 6* series KDG4V-3...H*, 6* series KDG5V-5/7/8, 1* series
EEA-PAM-525-A-33	KTG4V-5...H*, 3* series KDG4V-5...H*, 3* series
EEA-PAM-533-A-33	KFTG4V-3, 2* series KFDG4V-3, 2* series
EEA-PAM-535-A-33	KFTG4V-5, 2* series KFDG4V-5, 2* series
EEA-PAM-541-A-33	KHDG5V-5/7/8, 3* series With zero-lapped main spool
EEA-PAM-553-A-33	KSDG4V-3, 1* series
EEA-PAM-561-A-33	KFDG5V-5, 3* series KFDG5V-7, 1* series
EEA-PAM-568-A-33	KFDG5V-8, 1* series
EEA-PAM-571-A-33	CVU-**-EFP1-3*
EEA-PAM-581-A-33	KHDG5V-5/7/8, 3* series

Type A amplifier for proportional control valves

Front panel

Model

523, 525, 533, 535, 561, 568 and 581

LEDs

- [1] 24V supply voltage, green
- [2] 15V control voltage, green
- [3] Solenoid output enabled, yellow
- [4] Solenoid output overload, red
- [5] LVDT failure, red
- [6] Drive to solenoid, yellow

Potentiometers

- [7] Deadband compensation, flow from P to B
- [8] Deadband compensation, flow from P to A
- [9] Gain, flow from P to B
- [10] Gain, flow from P to A

LED

- [11] Ramps enabled, yellow

Potentiometers

- [12] Acceleration ramp
- [13] Deceleration ramp

Monitor points ▲

- [14] Conditioned command signal MP1
- [15] Common ground 0V
- [16] Spool position MP2
(except for 523/525: solenoid current)

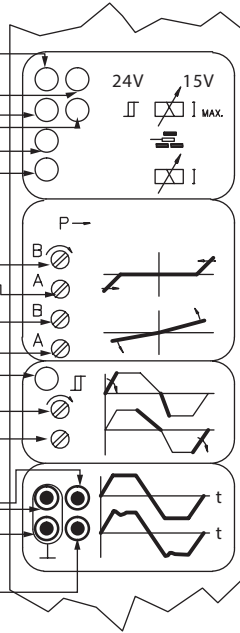

513

Potentiometers

- [17] Zero adjust
- [18] Gain

Monitor point ▲

- [19] Solenoid current MP2

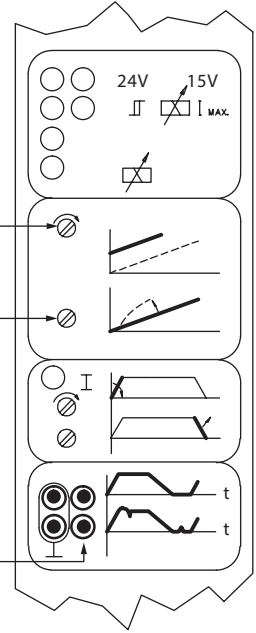

541, 553

Potentiometer

- [20] Adjust valve zero

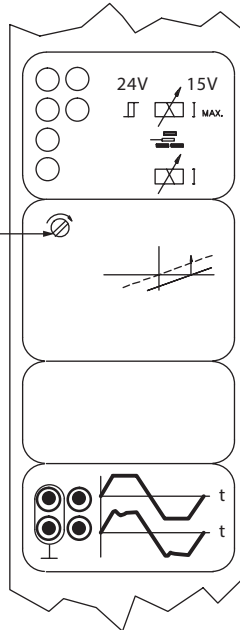

571

Potentiometers

- [21] Deadband compensation
- [22] Gain

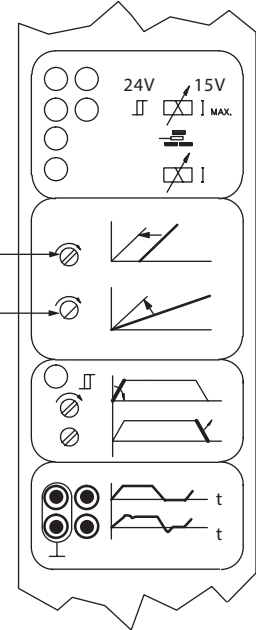

▲ Ø 2 mm (0.0787 " dia.) sockets

Type A Amplifier for proportional control valves

Electrical block diagram

EA-PAM-523/525-A-33

533/535

561/568

571

581

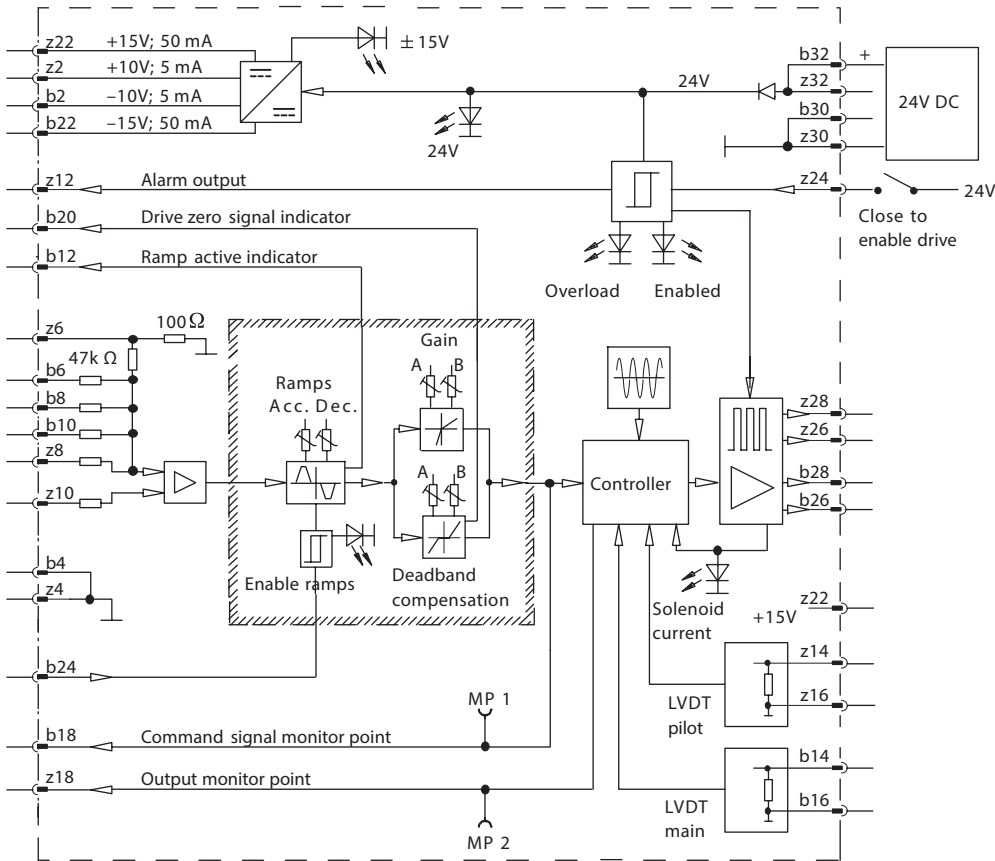

EEA-PAM-513-A-33

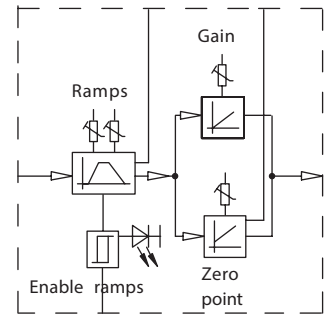

EEA-PAM-541-A-33

553

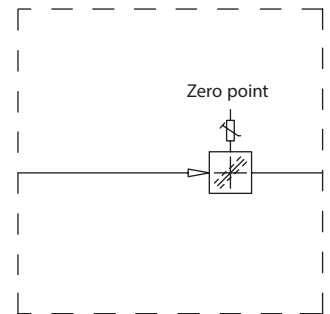

Note: This is a typical diagram and all the features depicted may not be applicable to all amplifiers, (e.g. LVDTs and dither)













Table 3.

Command signals and outputs				All models except 553 and 571	553	571
Non-inverting voltage b6/8/10 or z8	Non-inverting current z6	Inverting voltage z10	Secondary pins	Output		
-			bz4			
	-		bz4	P to A	P to B	Valve closed
		+	bz4			
-		+	N/A			
+			bz4			
	+		bz4	P to B	P to A	A to B and B to A
		-	bz4			
+		-	N/A			

Type A Amplifier for proportional control valves

Operating data

Table 3. continued

Power supply:	
Nominal	24V DC x 50W
Vmin. - Vmax.	20 - 40V (incl. pk-to-pk. ripple 10% max.)
Amplifier shut-down	<18V DC
Protection	Reverse-polarity
Signal sources:	
—○ z22 & b22	± 15V x 50 mA max. (pk-to-pk. ripple 50 mV)
—○ z2 & b2	± 10V (1%) x 5 mA max. (pk-to-pk. ripple 20 mV)
Temperature drift	< 1 mV/°C (<0,5 mV/°F) 0-50°C (32 - 122°F)
All outputs short-circuit protected	
Command inputs	
Voltage:	
Direct-V	—○ b8, b6, z8 & b10
Inverting-V	—○ z10
Umin. - Umax.	0 ± 10V
Input 	47 kΩ
Current —○ z6:	
Range, I	0 ± 20 mA
Input 	100Ω
Power drive	 = PWM short-circuit protected
Max. solenoid current	See table on next page
Current at zero (0V command signal on MP1)	See table on next page
Dither	Factory-set
Deadband compensation	See table on next page
Gain	See table on next page
Ramp-time adjustment:	
Factory setting	Min. ≈ 50 ms
 min. - max.	50 ms - 5s
 min. - max.	50 ms - 5s
Overload detection	Automatic reset
Drive:	
Enabled —○ z24	>9.8 - <40V
Disabled —○ z24	Open circuit or ≤ 4.5V
Input 	22 kΩ
Ramps:	
Enabled —○ b24	>9.8 - <40V
Disabled —○ b24	Open circuit or ≤ 4.5V
Input 	22 kΩ
Command signal monitor point:	
Front-panel  & —○ b18	Monitor signal after deadband compensation (minimum setting), gain and ramps: 0 - 10V (10V ΔImax)
Output 	10 kΩ short-circuit protected
Output Monitor Point (Main)  :	
Front-panel  & —○ z18	513/523/525 (without LVDT): 1 V/A
Output 	Other types (with LVDT): ± 10V at full stroke 10 kΩ short-circuit protected

Type A Amplifier for proportional control valves

Table 3. continued







Output monitor point (Pilot)  : —○ z20 Output 	541/581 (with LVDT): $\pm 10V$ at full stroke 10 k Ω short-circuit protected
Ramp-active indicator —○ b12  Output 	Output > + 10V Output < - 10V Output = 0V ($\pm 2V$ ripple) 10 k Ω
Drive signal zero indicator —○ b20 Drive signal at null (within deadband limits) Drive active Output resistance 	Output = Supply minus 1.5V; I = 50 mA max. Output = 0 $\pm 2V$ 50 Ω
Alarm output —○ z20 Set alarm Signal	Enable amplifier (on pin z24) when switching power on HIGH when alarm is activated: Output = Supply volts minus 2 volts; I = 50 mA max. LOW when solenoid overload has occurred (maintained until reset): Output = 0 to ± 2 volts; Output impedance = 50
Reset after failure	Disable and re-enable on pin z24
Ambient temperature range	0 - 50 °C (32 - 122 °F) full specification
Edge connectors DIN 41612	On board F48 Male Mating connector F32 Female (rows b and z only) for Type-A only Mating connector F48 Female compatible with all card Types A through F
	330g (0.15 lb)
Cardholder	F32 02-104807 compatible with card Type-A only F48 02-104808 compatible with all card Types A through F

Table 4.

Model	513	523 525	533	535	541	553	561 568	571	581
Max. solenoid current	1.6A	1.6A	2.7A	2.7A	3.2A	3.2A	1.8A	2.9A	3.2A
Amplifier input current at 0V command signal (MP1)	0.3A	0.3A	0.3A	0.3A	1.7A	1.7A	1.4A	1.1A	1.7A
Deadband compensation									
Factory setting (% of max. spool stroke)	-	25%	15%	10%	-	-	10%	10%	10%
Adjustment per direction (% of max. spool stroke from centered position)	-	0 - 50%	0 - 50%	0 - 50%	-	-	0 - 50%	0 - 50%	0 - 50%
Gain									
Factory setting	10%/V	10%/V	10%/V	10%/V	10%/V	10%/V	10%/V	10%/V	10%/V
Adjustment per direction	2.5 - 10%/V	2.5 - 10%/V	2.5 - 10%/V	2.5 - 10%/V	-	-	2.5 - 10%/V	2.5 - 10%/V	2.5 - 10%/V
Zero adjustment (% of max. spool stroke)	0 - 50%	-	-	-	$\pm 25\%$	$\pm 25\%$	-	-	-

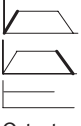
Type A Amplifier for proportional control valves

Wiring connections

Amplifier models to Typical Valve Type

Amplifier models:513, 523, 525

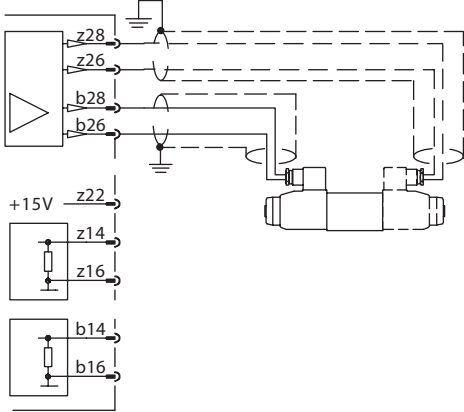

Amplifier models:533, 535

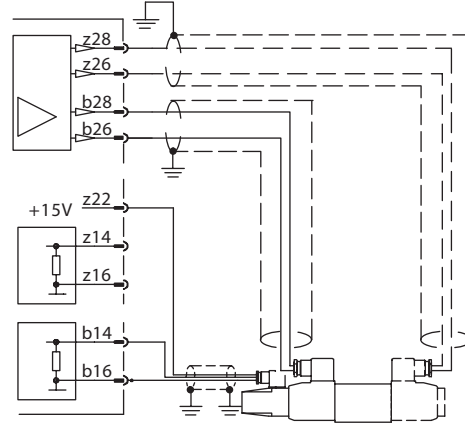

Amplifier model:553

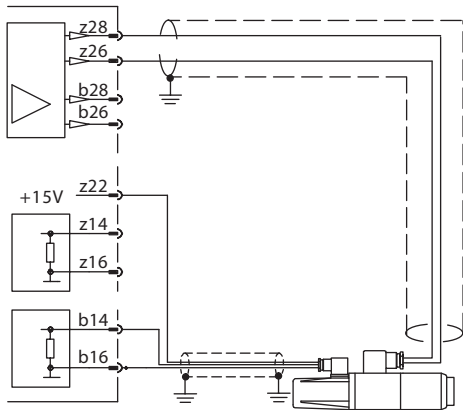

Amplifier models:561, 568

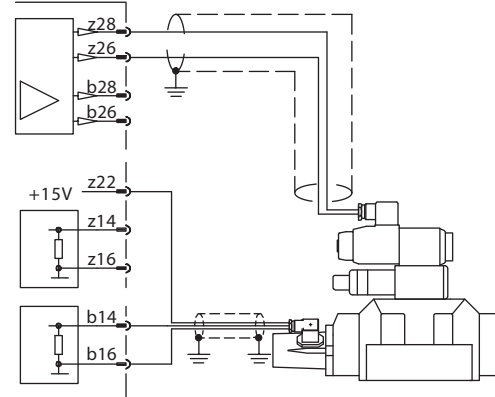

Amplifier models:541, 581

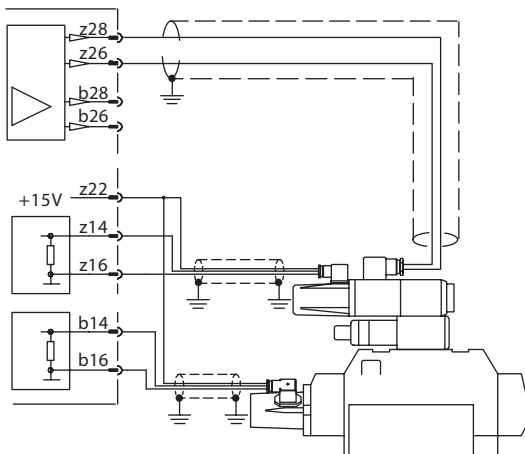

Amplifier model:571

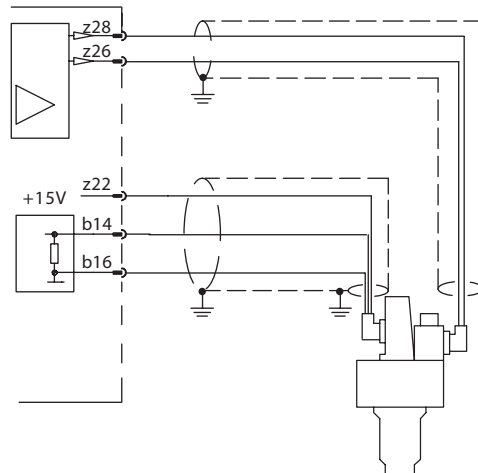

⏏ Customer & protective ground connection.

Note: If valves are fitted with the "B" type LVDT, the screen will be grounded at the valve end by the shell of the connector.

Type A amplifier for proportional control valves

Typical input connection circuitry

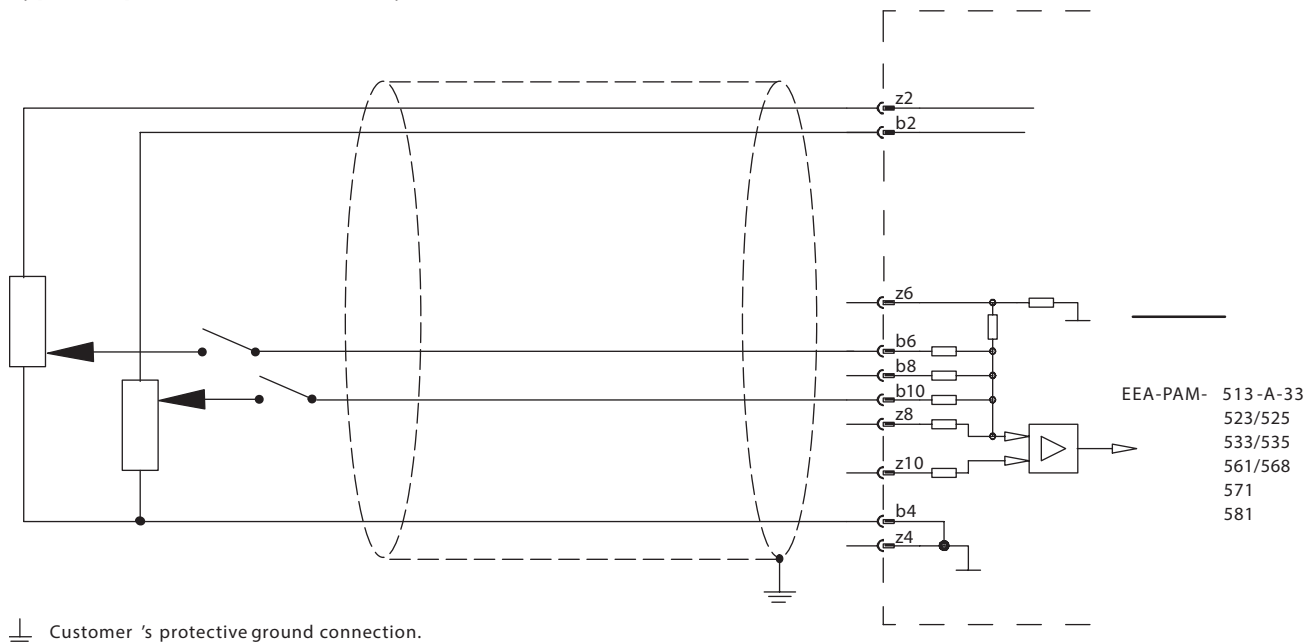

Valve solenoid connections

z26/28 (b26/28)

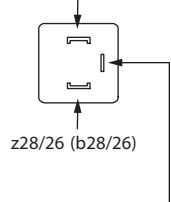

z28/26 (b28/26)

Protective ground: Connection not required if power supply conforms to VDE 0551/EN 60742/IEC 742

LVDT connections

M & E type

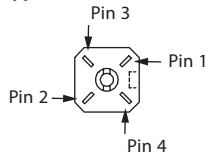

B type (EMC)

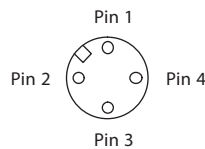

	LVDT plug pin	Amplifier pin
Pilot stage	1	z14
	2	z22
	3	z16
	4	Not connected
Main stage +CVU-EFP1	1	b14
	2	z22
	3	b16
	4	Not connected

⚠ WARNING

Electromagnetic Compatibility (EMC)

1. Screened cables should be used for the command signals, the solenoid connections and the LVDT connections.
2. Particular attention should be paid to the grounding of the screens as shown in the diagrams.
3. The screen on the LVDT cable needs to be grounded at both ends. An alternative method to prevent creating earth loops is to use double screened cable with each screen grounded at opposite ends.
4. The amplifiers should be mounted in a metal enclosure which is connected to an efficient ground point.

Type A amplifier for proportional control valves

Installation dimensions in mm(inches)

Plug-in Unit of 3U Height (IEC 297)

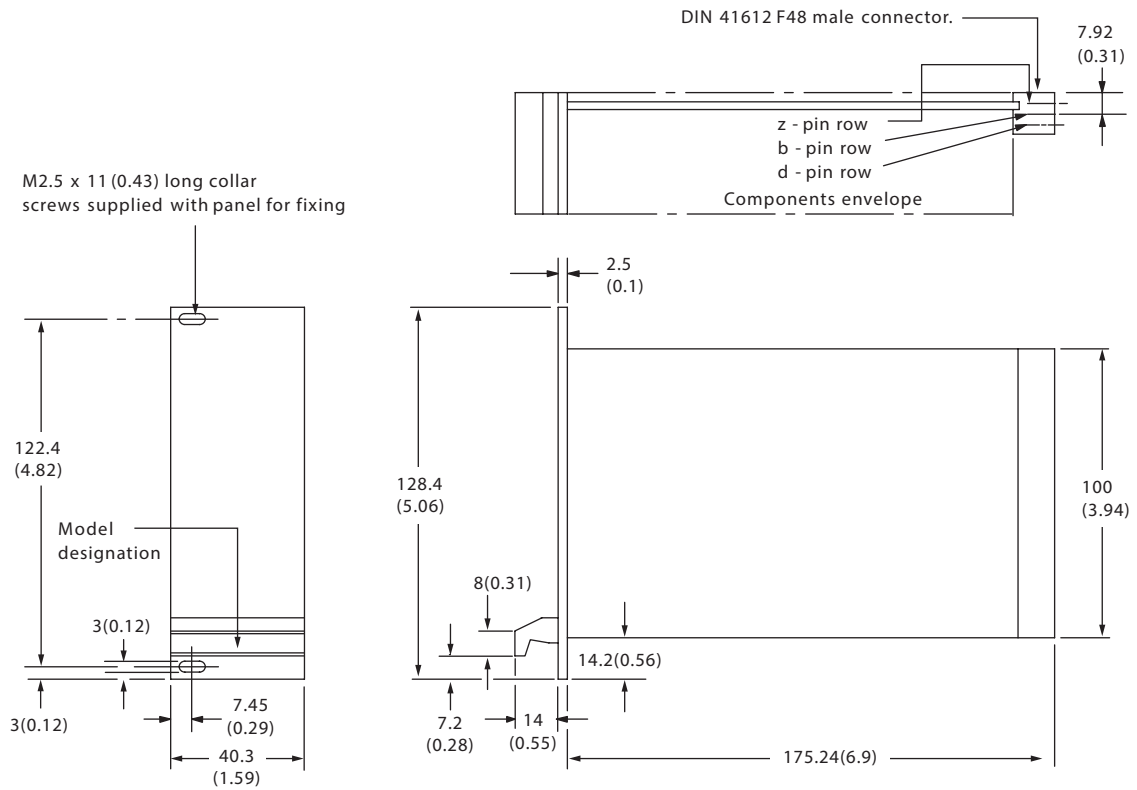
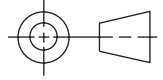

Type A amplifier for proportional control valves

Dedicated installation requirement for Type A card

Wiring sizes

Use 3-core screened cable $\geq 0.5 \text{ mm}^2$ (20 AWG) per wire for signal and LVDT wiring.

For wiring runs between amplifier and solenoid up to 50 meters (164 ft): EEA-PAM -523 and EEA-PAM -525 must have a wire cross-section of 1.5 mm^2 (15 AWG); for all other models use wire of $\geq 1 \text{ mm}^2$ (18 AWG) cross-section.

Front panel controls

Any of the following controls may be on the front panel (depending on the amplifier type) and can be adjusted as described.

1. Set zero:

On amplifier types 513, 541 and 553, this sets the electrical null of the valve.

2. Deadband compensation:

The two potentiometers are factory set at 10% (20% for 523 models) of valve maximum spool stroke. The setting may be optimized for your application as follows:

Apply a small command signal (e.g. 250 mV) and check for hydraulic response from the valve. (For 2-stage valves the correct pilot pressure must be available to obtain response from the main-stage spool.) If this does not occur then adjust the applicable potentiometer clockwise until it does. Alternatively, to reduce valve hydraulic response turn the potentiometer counter-clockwise.

3. Gain

The gain potentiometers are factory set for 100% output at 10V command signal. Turning the gain potentiometers clockwise increases the gain; turning counter-clockwise reduces gain.

4. Ramps





Factory setting of ramp potentiometers: all amplifiers are set to minimum ramp time.

Turning the controls clockwise increases ramp time; turning counter-clockwise decreases ramp time. There are separate controls for accelerating and for decelerating ramps.

5. Front panel indicator lights (LEDs)

Amplifiers may have some, or all, of the following LEDs, depending on amplifier type:

Table 5.

Panel symbol	Function indicated	Color	Normal working state
24V	Power supply ON	Green	ON
15V	Internal supply ON	Green	ON
	Output enabled	Yellow	ON
	Overload detection	Red	OFF
	LVDT failure	Red	OFF
	Ramps enabled	Yellow	ON
	Current to solenoid (Light intensity varies with solenoid current)	Yellow	ON

6. Fault diagnosis

If the amplifier fails to work the following checks should be made:

1. Check that all wiring is correct to the machine designer's instructions.
2. Check that there is a 24V supply and that the 24V LED is ON.
3. Check that the 15V internal voltage LED is ON (if 24V LED is ON and this 15V LED is OFF then the amplifier should be replaced.)
4. Check that the amplifier is enabled and the LED is ON.
5. Check that the LVDT failure LED is OFF. (If ON check the LVDT wiring and connections.)

To check correct function of the amplifier, disconnect all valve connections and link z22 (+15V) with a 1.2 kΩ resistor to b14. (To check the double feedback amplifiers EEA-PAM -581/541, make an additional link between z22 (+15V) and z14 with a 1.2 kΩ resistor.)

After installation of resistor link(s), the LVDT failure LED should be OFF. If not, replace the amplifier (caution: a link without resistor damages the amplifier).
6. Check that the overload LED is OFF. (If ON, check the wiring to the solenoids and the solenoid resistance by an ohmmeter. Compare the measured value with the catalog data.)
7. Check that an appropriate valve driving signal is available (monitor point at the front panel).
 - $\pm 10\text{V}$ at monitor point represents $\pm 100\%$ output
8. The solenoid current (non-feedback valves) or the LVDT signal (feedback valves) can be measured at the front panel monitor point.
 - Solenoid current can be measured as a voltage signal (1 volt per amp)
 - $\pm 10\text{V}$ LVDT signal at monitor point represents $\pm 100\%$ spool stroke

Type A amplifier for proportional control valves

Valve connection table

This table shows how the different valves have to be connected to the associated amplifier.

Table 6.

Value type	Amplifier type	Solenoid with LVDT or hydraulic A	Solenoid without LVDT or hydraulic B
KCG-3/6/8 and KX(C)G-6/8	EEA-PAM-513-A-33	b26/b28	-
K*G4V-3 and KDG5V-5/7/8	EEA-PAM-523-A-33	b26/b28	z26/z28
K*G4V-5	EEA-PAM-525-A-33	b26/b28	z26/z28
KF*G4V-3	EEA-PAM-533-A-33	b26/b28	z26/z28
KF*G4V-5	EEA-PAM-535-A-33	b26/b28	z26/z28
KHDG5V-5/7/8 zero lapped	EEA-PAM-541-A-33	-	z26/z28
KSDG4V-3	EEA-PAM-553-A-33	-	z26/z28
KFDG5V-5/7	EEA-PAM-561-A-33	-	z26/z28
KFDG5V-8	EEA-PAM-568-A-33	-	z26/z28
CVU-**-EFP1	EEA-PAM-571-A-33	-	z26/z28
KHDG5V-5/7/8	EEA-PAM-581-A-33	-	z26/z28

Table 7.

Valve type	Pilot stage LVDT					Main stage LVDT			
	Pin 1	2	3	4		Pin 1	2	3	4
KCG-3/6/8 and KX(C)G-6/8	-	-	-		Not connected	-	-	-	
K*G4V-3 and KDG5V-5/7/8	-	-	-			-	-	-	
K*G4V-5	-	-	-			-	-	-	
KF*G4V-3	-	-	-			b14	z22	b16	
KF*G4V-5	-	-	-			b14	z22	b16	
KHDG5V-5/7/8 zero lapped	z14	z22	z16			b14	z22	b16	Not connected
KSDG4V-3	-	-	-			b14	z22	b16	
KFDG5V-5/7	-	-	-			b14	z22	b16	
KFDG5V-8	-	-	-			b14	z22	b16	
CVU-**-EFP1	-	-	-			b14	z22	b16	
KHDG5V-5/7/8	z14	z22	z16		b14	z22	b16		

Type B amplifier with command logic module and 2 ramps

General description

The EEA-PAM -5**-B -33 Eurocards are power amplifiers with a four-input (demand signal) module and ramp function generator with quadrant detection for separate adjustment of acceleration and deceleration.

The type of EEA-PAM -5**-B -33 amplifier used depends on the type of proportional valve, see "Model Codes".

Features and benefits

- Includes all features of "A" amplifiers
- 2 ramp times set by front-panel potentiometers; can be varied by external voltage signals
- 4 adjustable command pre-sets selectable by 24V logic signal
- Polarity of 10V reference voltage selectable by 24V logic signal
- CE electromagnetic compatibility-2014/30/EU
- RoHS Compatibility-DIRECTIVE 2011/65/EU

Front panel

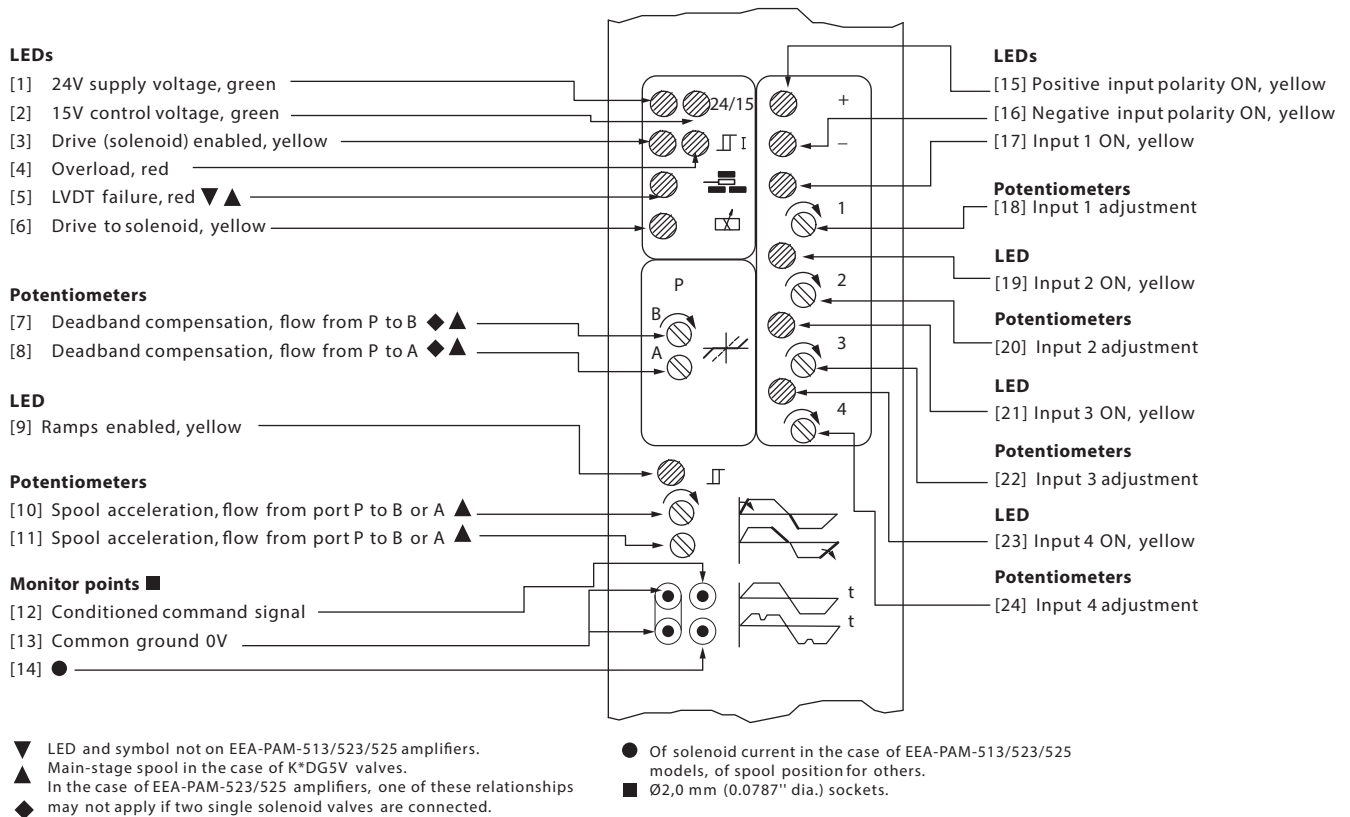

Model codes

Table 8.

Amplifier model	For valves
EEA-PAM-513-B-33	KCG-3; KCG-6/8
	KX(C)G-6/8
EEA-PAM-523-B-33	K*G4V-3; KDG5V-5/7/8
EEA-PAM-525-B-33	K*G4V-5
EEA-PAM-533-B-33	KF*G4V-3
EEA-PAM-535-B-33	KF*G4V-5
EEA-PAM-561-B-33	KFDG5V-5/7
EEA-PAM-568-B-33	KFDG5V-8
EEA-PAM-571-B-33	CVU**-EFP1
EEA-PAM-581-B-33	KHDG5V-5/7/8

} With type "H" coils only

Type B amplifier with command logic module and 2 ramps

Operating data

Table 9.

Power requirements:	z22	+15V for LVDTs only
Output voltages for control:		See appropriate base amplifier, e.g. for EEA-PAM-535-B-33 see EEA-PAM-535-A-33
Control (output) supplies:		
At pin z2		+10V (± 1 %) x 5 mA
At pin b2		-10V (± 1 %) x 5 mA
At pins z2 and b2		Ripple <20 mV pk-to-pk. Temperature drift <1 mV/° C (<0.5 mV/° F) thru' 0-50° C (32-122° F) range All outputs short-circuit protected
Command signal inputs:		
Direct-voltage pins	b8, b6,z8, b10	
Inverting-voltage pin	z10	
Voltage range		±10V
Input impedance (voltage)		47kΩ
Current pin z6		
Current range		±20mA
Input impedance (current)		100Ω
Command voltage source:	d20	±10V x 10mA
Command voltage polarity selection:		
For flow from (main) port P to A ▲		Pin d2 at 0 to +5V
For flow from (main) port P to B ▲		Pin d2 at +10 to +40V
Input impedance		47kΩ
Warning: Loss of signal at pin d2 causes polarity reversal and possible erratic motion.		
▲ In the case of EEA-PAM-523/525 amplifiers, one of these relationships may not apply if two single-solenoid valves are connected.		
Logic inputs:		
Switch-on voltage		+10 to +40V
Switch-off voltage		<+5V
Input current	d10, d12, d14 or d18	≤10mA
Command voltage inputs: d22, d24, d26 and d28		
Voltage and source		+10V gives valve flow from port P to B, or -10V gives flow from P to A*
Input impedance		Four 50kΩ pots
External command potentiometer		5kΩ; 0.25W minimum Part no. 714127; see catalog 2460 * Not applicable when using EEA-PAM-523/525 amplifiers to drive two single-solenoid valves.
Voltage-controlled ramp generator:		
Acceleration pin	d6	±10V
Deceleration pin	d8	±10V
		Note: At any ramp pot. setting, positive voltages increase ramp times and negative voltages decrease them. With pot. set at zero, 0 to +10V equates to a ramp time range of 50ms to 5s. With pot. set at max., 0 to -10V equates to a ramp time of 5s to 50 ms.
Input impedance	d6 or d8	10kΩ
Drive enabled (power available to solenoid)	z24	Apply >9.8V to <40V (22kΩ)
Drive disabled (no power to solenoid)	z24	Apply open circuit or up to 4.5V
Alarm output:	z12	Enable amplifier (on pin z24) when switching power on
Set alarm		HIGH when alarm is activated
Signal		Output = Supply minus 2V I = 50 mA max. LOW when solenoid overload has occurred. (Maintained until reset.) Output = 0 to ± 2 volts Output resistance = 50 ohms
Reset after failure		Disable and re-enable on pin z24

Type B amplifier with command logic module and 2 ramps

Table 9. continued

Ramps enabled (valve switching rate limited by ramp potentiometers)	b24	Apply >9.8V to <40V (22 k Ω)
Ramps disabled (fastest valve switching; ramp circuit bypassed)	b24	Apply open circuit or up to 4.5V
Ramp active indicator:	b12	
Drive ramping up		Output >10V
Drive ramping down		Output <-10V
Drive not ramping		Output 0V ($\pm 2V$ ripple)
Output resistance		10k Ω
Drive signal zero indicator:	b20	
Drive signal at null (within deadband limits)		Output = Supply minus 1.5V I = 50 mA max.
Drive active		Output = 0 $\pm 2V$
Output resistance		50 Ω
Ambient temperature range		0 to 50° C (32 to 122° F)
Storage temperature range		-25 to +85° C (-12 to +185° F)
Edge connectors		DIN 41612 F48 male type on board. Mating connector must be an F48 female type
Installation dimensions and panel display		Dimensions are the same as for the corresponding base amplifier but the panel display is different; see first page
Mass		0.40 kg (0.88 lb) approx.
Other characteristics		See the relevant base amplifier EEA-PAM-5***-A-33.
Cardholder	F48	02-104808

WARNING

Electromagnetic Compatibility (EMC)

This product has been designed and tested to meet specific standards outlined in the European Electromagnetic Compatibility Directive (EMC) 2014/30/EU which repealed Directive 89/336/EEC, amended by Directives 91/263/EEC, 92/31/EEC, 93/68/EEC and 93/97/EEC. For instructions on installation requirements to achieve effective protection levels, see this leaflet and the Installation Wiring Practices for Vickers Electronic Products leaflet 2468. Wiring practices relevant to this Directive are indicated by Electromagnetic Compatibility (EMC).

Type B amplifier with command logic module and 2 ramps

Circuit and Connections

EEA-PAM-5**-B-33

Shown with command logic module. Individual ramp adjustments of spool acceleration and deceleration, independent of direction of movement, are on the base amplifier. Additionally, acceleration and deceleration can

be controlled by variable voltage inputs to pins d6 and d8 respectively. The circuit here includes the essential characteristics of all amplifiers listed in the "Model Codes" section, two pages back; actual amplifiers omit certain sub-circuits to those connection pins not needed for the valves concerned.

Note: Read circuit in conjunction with that for relevant base amplifier EEA-PAM-5**-A

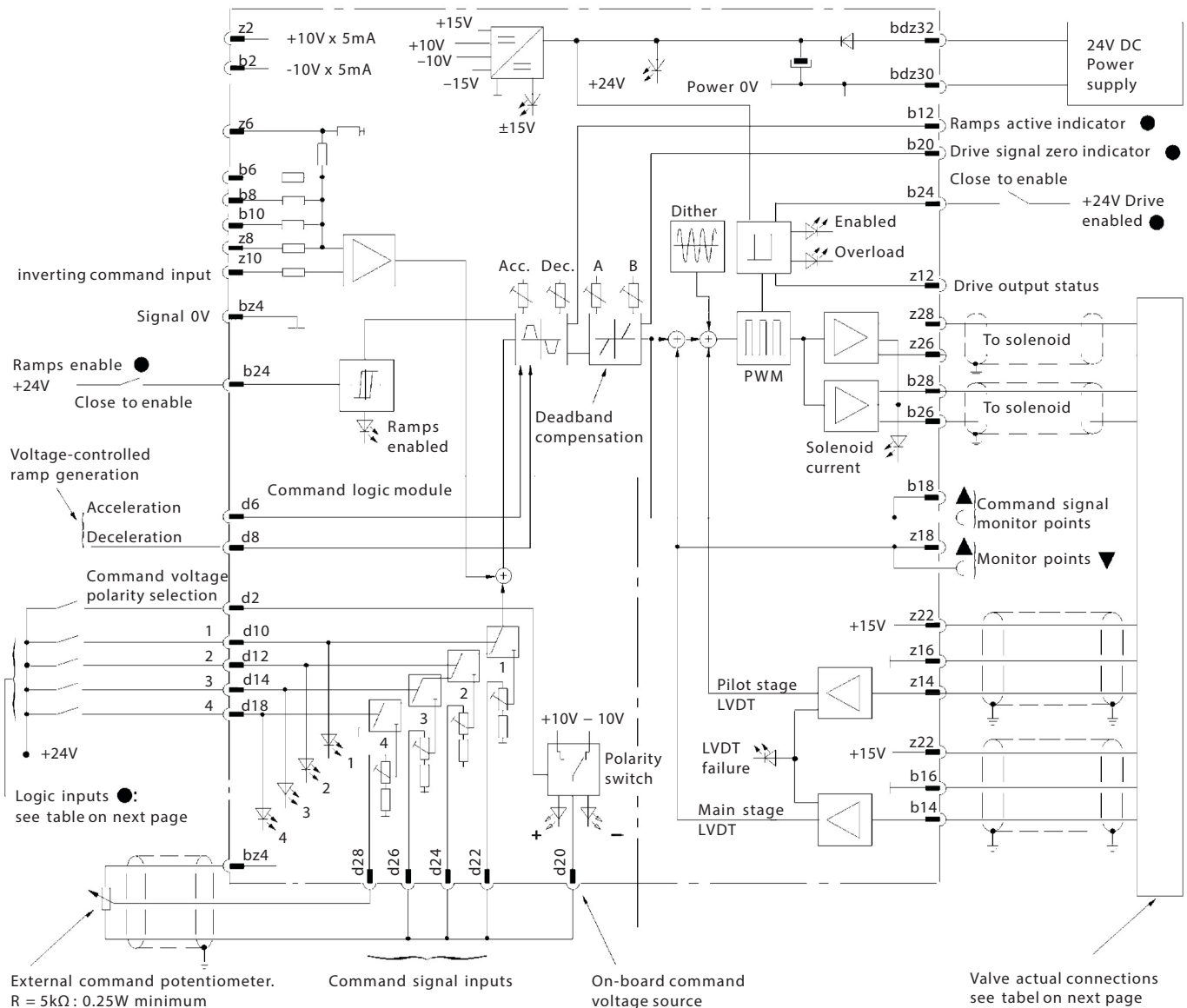

- ⊥ Customer's protective earth connection.
- ▼ Solenoid current for 523/525-B models; LVDT position for all others.
- ▲ On front panel.
- See under this heading in "Operating Data" table.

Type B amplifier with command logic module and 2 ramps

Table 10. Logic selection inputs

Logic input pin	Command pot.	Secondary pin	Voltage to pin d2	Valve flow	
d10	1	bdz30	0 +24V	P-A P-B	}■
d12	2	bdz30	0 +24V	P-A P-B	}■
d14	3	bdz30	0 +24V	P-A P-B	}■
d18	4	bdz30	0 +24V	P-A P-B	}■

■ In the case of EEA-PAM-523/525-B models, one of these relationships may not apply if two single-solenoid valves are connected.

Solenoid and LVDT connections for proportional valves

Table 11.

Amplifier type	Solenoid with LVDT and/or for flow P to B	Solenoid without LVDT, or on pilot valve	Pilot-stage LVDT, (black plug):				Main-stage LVDT, (gray plug):			
			Pin 1	Pin 2	Pin 3	Pin 4	Pin 1	Pin 2	Pin 3	Pin 4
EEA-PAM-513-B-33	b26/b28	-	-	-	-	Not connected	-	-	-	Not connected
EEA-PAM-523-B-33	b26/b28	z26/z28	-	-	-	Not connected	-	-	-	Not connected
EEA-PAM-525-B-33	b26/b28	z26/z28	-	-	-	Not connected	-	-	-	Not connected
EEA-PAM-533-B-33	b26/b28	z26/z28	-	-	-	Not connected	b14	z22	b16	Not connected
EEA-PAM-535-B-33	b26/b28	z26/z28	-	-	-	Not connected	b14	z22	b16	Not connected
EEA-PAM-561-B-33	-	z26/z28	-	-	-	Not connected	b14	z22	b16	Not connected
EEA-PAM-568-B-33	-	z26/z28	-	-	-	Not connected	b14	z22	b16	Not connected
EEA-PAM-571-B-33	-	z26/z28	-	-	-	Not connected	b14	z22	b16	Not connected
EEA-PAM-581-B-33	-	z26/z28	z14	z22	z16	Not connected	b14	z22	b16	Not connected

Type B amplifier with command logic module and 2 ramps

Installation dimensions in mm (inches)

Plug-in Unit of 3U Height, to IEC 297

3rd angle projection 

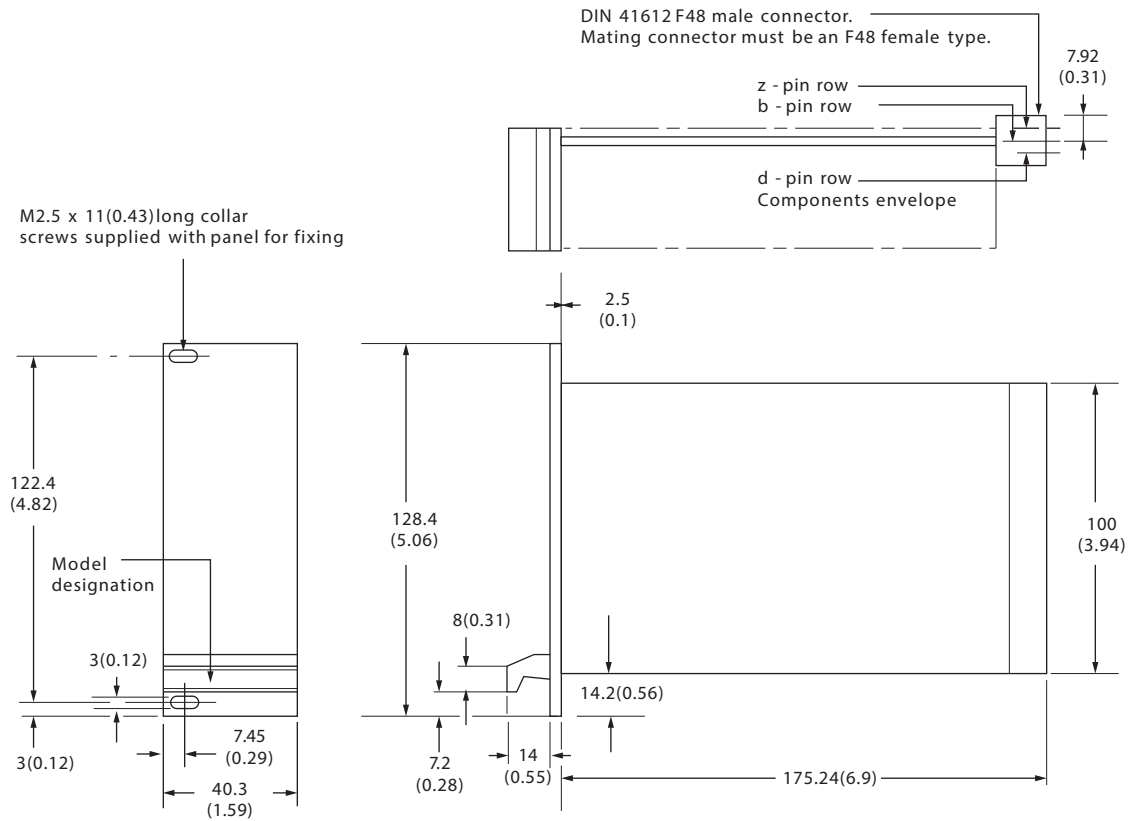

Type C amplifier with command logic module and 4 ramps

General description

The EEA-PAM -5**-C-33 Eurocards are power amplifiers with a 4-input (demand signal) module and 4-ramp function generator with quadrant detection. The ramp generator allows acceleration and deceleration to be set separately for both directions of movement.

The type of EEA-PAM -5**-C-33 amplifier used depends on the type of proportional valve, see "Model Codes" on next page.

Features and benefits

- All features of "A" amplifiers
- 4 adjustable ramp times, 4-quadrant acceleration/ deceleration
- 4 adjustable command pre-sets selectable by 24V logic signal
- Polarity of the 10V reference voltage selectable by 24V logic signal
- CE electromagnetic compatibility.-2014/30/EU
- RoHS Compatibility-DIRECTIVE 2011/65/EU

Front panel

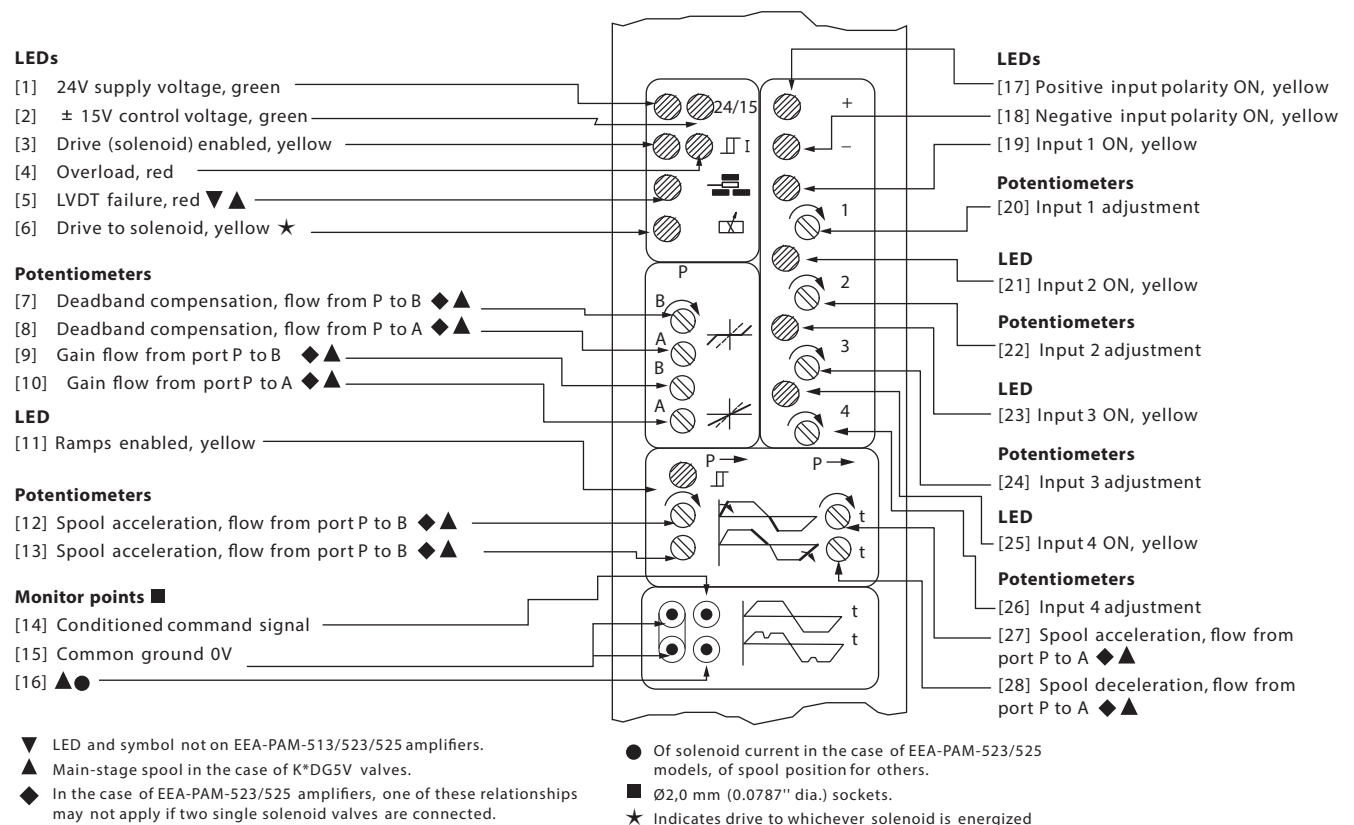

WARNING

Electromagnetic Compatibility (EMC)

It is necessary to ensure that the valve is wired up in accordance with the connection arrangements shown in this leaflet. For effective protection, the user's electrical cabinet, the valve subplate or manifold and the cable screens should be connected to efficient earth (ground) points. In all cases, both valve and cable should be kept as far away as possible from any source of electromagnetic radiation such as cables carrying heavy current, relays and certain kinds of portable radio transmitters, etc. Difficult environments could mean that extra screening may be necessary to avoid the interference.

Type C amplifier with command logic module and 4 ramps

Model codes

Table 12.

Amplifier model	For valves
EEA-PAM-523-C-33	K*G4V-3; KDG5V-5/7/8
EEA-PAM-525-C-33	K*G4V-5
EEA-PAM-533-C-33	KF*G4V-3
EEA-PAM-535-C-33	KF*G4V-5
EEA-PAM-561-C-33	KFDG5V-5/7
EEA-PAM-568-C-33	KFDG5V-8

} With type "H" coils only

Operating data

Table 13.

Power requirements:	See appropriate base amplifier, e.g. for EEA-PAM-535-C-33 see EEA-PAM-535-A-33
Control (output) supplies:	z22 +15V for LVDTs only
Output voltages for control:	
At pin z2	+10V (±1%) x 5 mA
At pin b2	-10V (±1%) x 5 mA
At pins z2 and b2	Ripple <20 mV pk.-to-pk. Temperature drift <1 mV/°C (<0.5 mV/° F) thru' 0-50°C (32-122°F) range All outputs short-circuit protected
Command signal inputs:	
Direct-voltage pins	b8, b6,z8, b10
Inverting-voltage pin	z10
Voltage range	±10V
Input impedance (voltage)	47kΩ
Current pin z6	
Current range	±20mA
Input impedance (current)	100Ω
Command voltage source:	d20 ±10V x 10mA
Command voltage polarity selection:	
For flow from (main) port P to A ▲	Pin d2 at 0 to +5V
For flow from (main) port P to B ▲	Pin d2 at +10 to +40V
Input impedance	47kΩ
Warning: Loss of signal at pin d2 causes polarity reversal and possible erratic motion. ▲ In the case of EEA-PAM-523/525 amplifiers, one of these relationships may not apply if two single-solenoid valves are connected.	
Logic inputs:	
Switch-on voltage	+10 to +40V
Switch-off voltage	<+5V
Input current	d10, d12, d14 or d18 ≤10 mA
Command voltage inputs:	d22,d24,d26 and d28
Voltage and source	+10V gives valve flow from port P to B, or -10V gives flow from P to A*
Input impedance	Four 50kΩ pots
External command potentiometer	5kΩ; 0.25W minimum Part no. 714127; see catalog 2460 *Not applicable when using EEA-PAM-523/525 amplifiers to drive two single-solenoid valves.

Type C amplifier with command logic module and 4 ramps

Table 13. continued

Drive enabled (power available to solenoid)	z24	Apply >9.8V to <40V (22 kΩ)
Drive disabled (no power to solenoid)	z24	Apply open circuit or up to 4.5V
Alarm output:	z12	Enable amplifier (on pin z24) when switching power on
Set alarm		HIGH when alarm is activated
Signal		Output = Supply minus 2V I = 50 mA max. LOW when solenoid overload has occurred. (Maintained until reset.) Output = 0 to ± 2 volts Output resistance = 50 ohms
Reset after failure		Disable and re-enable on pin z24
Ramps enabled (valve switching rate limited by ramp potentiometers)	b24	Apply >9.8V to <40V (22 kΩ)
Ramps disabled (fastest valve switching; ramp circuit bypassed)	b24	Apply open circuit or up to 4.5V
Ramp active indicator:	b 1 2	
Drive ramping up		Output >10V
Drive ramping down		Output <-10V
Drive not ramping		Output 0V (± 2V ripple)
Output resistance		10kΩ
Drive signal zero indicator:	b20	
Drive signal at null (within deadband limits)		Output = Supply minus 1.5V I = 50 mA max.
Drive active		Output = 0 ± 2V
Output resistance		50Ω
Ambient temperature range		0 to 50° C (32 to 122° F)
Storage temperature range		-25 to +85° C (-12 to +185° F)
Edge connectors		DIN 41612 F48 male type on board. Mating connector must be an F48 female type
Installation dimensions and panel display		Dimensions are the same as for the corresponding base amplifier but the panel display is different
Mass		0.40 kg (0.88 lb) approx.
Other characteristics		See the relevant base amplifier EEA-PAM-5**-A-33.
Cardholder	F48	02-104808

Type C amplifier with command logic module and 4 ramps

Circuit and connections

EEA-PAM-5**-C-33

Shown with command logic module. Individual ramp adjustments of spool acceleration and deceleration, independent of direction of movement, are on the base

Note: Read circuit in conjunction with that for relevant base amplifier EEA-PAM-5**-A

amplifier. The circuit here includes the essential characteristics of all amplifiers listed in the "Model Codes" section, actual amplifiers omit certain sub-circuits to those connection pins not needed for the valves concerned.

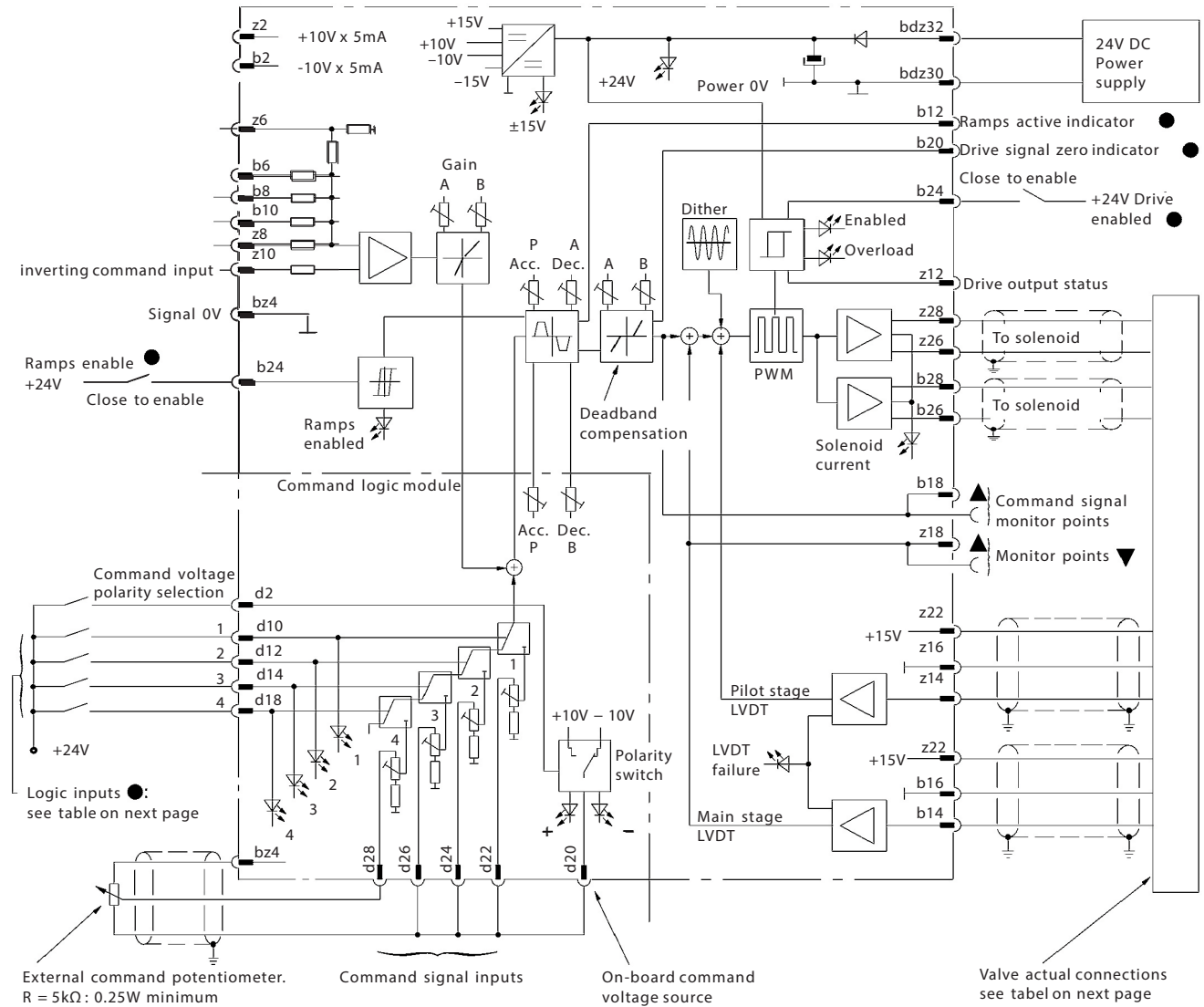

- ⊥ Customer's protective earth connection.
- ▼ Solenoid current for 523/525-C models; LVDT position for all others.
- ▲ On front panel.
- See under this heading in "Operating Data" table

Type C amplifier with command logic module and 4 ramps

Table 14. Logic Selection Inputs

Logic input pin	Command pot.	Secondary pin	Voltage to pin d2	Valve flow	
d10	1	bdz30	0 +24V	P-A P-B	}■
d12	2	bdz30	0 +24V	P-A P-B	}■
d14	3	bdz30	0 +24V	P-A P-B	}■
d18	4	bdz30	0 +24V	P-A P-B	}■

■ In the case of EEA-PAM-523/525-C models, one of these relationships may not apply if two single-solenoid valves are connected.

Solenoid and LVDT connections for proportional valves

Table 15.

Amplifier type	Solenoid with LVDT and/or for Flow P to B	Solenoid without LVDT, or on pilot valve	Pilot-stage LVDT, (black plug):				Main-stage LVDT, (gray plug):			
			Pin 1	Pin 2	Pin 3	Pin 4	Pin 1	Pin 2	Pin 3	Pin 4
EEA-PAM-523-C-33	b26/b28	z26/z28	-	-	-	Not connected	-	-	-	Not connected
EEA-PAM-525-C-33	b26/b28	z26/z28	-	-	-	Not connected	-	-	-	Not connected
EEA-PAM-533-C-33	b26/b28	z26/z28	-	-	-	Not connected	b14	z22	b16	Not connected
EEA-PAM-535-C-33	b26/b28	z26/z28	-	-	-	Not connected	b14	z22	b16	Not connected
EEA-PAM-561-C-33		z26/z28	-	-	-	Not connected	b14	z22	b16	Not connected
EEA-PAM-568-C-33		z26/z28	-	-	-	Not connected	b14	z22	b16	Not connected

Type C amplifier with command logic module and 4 ramps

Installation dimensions in mm(inches)

Plug-in Unit of 3U Height, to IEC 297

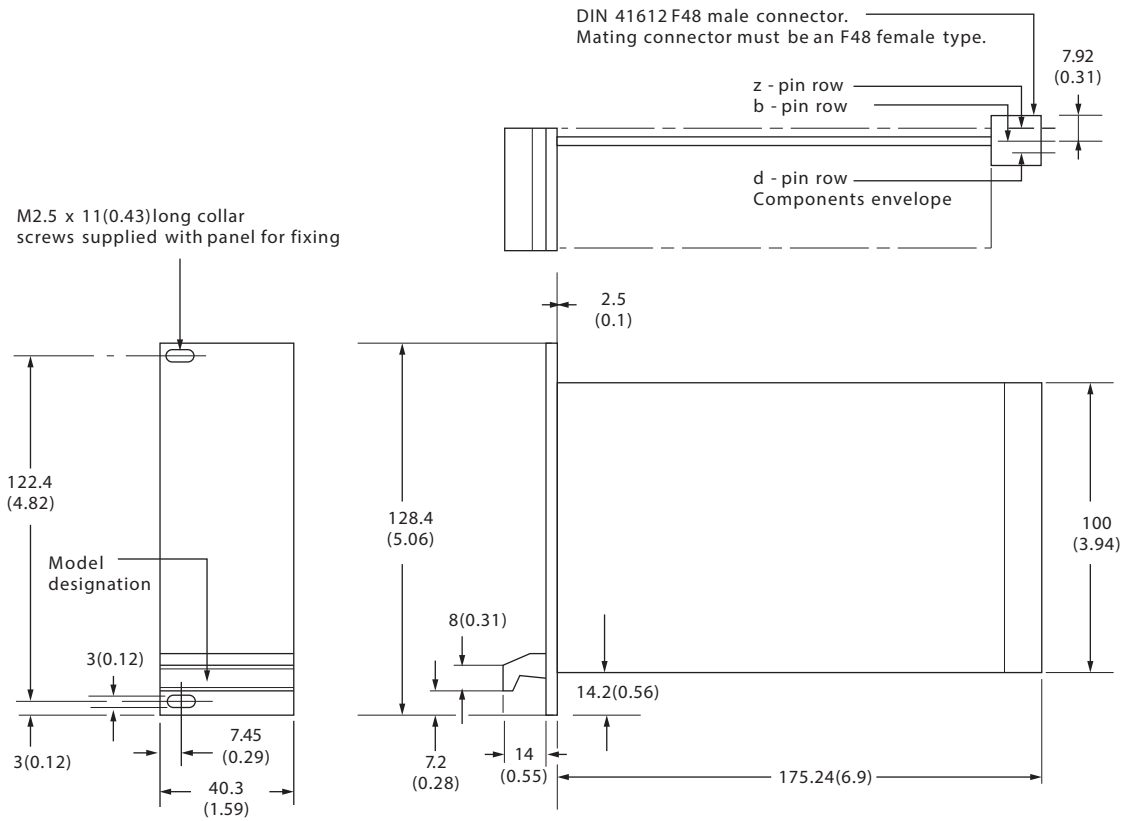
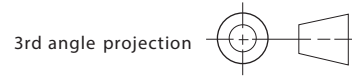

Type C amplifier with command logic module and 4 ramps

Dedicated installation recommendation for Type B & C card

The operation of this amplifier has been factory-checked before dispatch as meeting the specification shown in this catalog.

The amplifier is ready for use as supplied, but it must be properly installed by a qualified person using the machine designer's wiring diagram.

Wiring sizes

1. Use 3-core screened cable $\geq 0.5 \text{ mm}^2$ (20 AWG) per wire for signal and LVDT wiring.
2. For wiring runs between amplifier and solenoid up to 50 meters (164 ft): EEA-PAM-523 and EEA-PAM-525 must have a screened cable with a cross-section of 1.5 mm^2 (15 AWG)
3. For all other models use screened cable of $\geq 1 \text{ mm}^2$ (18 AWG) cross-section.

Front panel controls

Any of the following controls may be on the front panel (depending on the amplifier type) and can be adjusted as described.

1. Set zero:

On amplifier types 513-B this sets the electrical null of the valve

2. Deadband compensation:

The two potentiometers are factory set at 10% (20% for type 523) of valve maximum spool stroke. The setting may be optimized for your application as follows:

Apply a small command signal (e.g. 250 mV) and check for hydraulic response from the valve. (For 2-stage valves the correct pilot pressure must be available to obtain response from the main-stage spool.) If this does not occur then adjust the applicable potentiometer clockwise until it does. Alternatively, to reduce valve hydraulic response turn the potentiometer counter-clockwise.

A 250 mV command signal can be achieved by turning a selected command signal potentiometer counter-clockwise to the endstop.

3. Command Signals 1 to 4

Turning the input 1,2,3,4 adjustment potentiometers clockwise increases output, turning counter-clockwise reduces output. Use the four input adjustment potentiometers to set four independent command signals.

4. Gain (only available with type C)

The gain potentiometers are factory set for 100% output at 10V command signal. Turning the gain potentiometers clockwise increases the gain, turning counter-clockwise reduces gain.

5. Ramps

The factory settings of ramp potentiometers are minimum ramp time. Turning the controls clockwise increases ramp time, turning counter-clockwise decreases ramp time. On type B there are two separate controls for accelerating and for decelerating ramps, valid for both directions of movement.





On type C there are four separate controls for both accelerating and for decelerating ramps, independently adjustable for both directions.

Type C amplifier with command logic module and 4 ramps

3. Front panel indicator lights (LEDs)

Amplifiers may have some, or all, of the following LEDs, depending on amplifier type:

Table 16.

Panel symbol	Function indicated	Color	Normal working state
24V	Power supply ON	Green	ON
15V	Internal supply ON	Green	ON
	Output enabled	Yellow	ON
	Overload detection	Red	OFF
	LVDT failure	Red	OFF
	Ramps enabled	Yellow	ON
	Current to solenoid (Light intensity varies with solenoid current)	Yellow	ON

4. Valves connection table

Table 17.

Value type	Amplifier type	Solenoid with LVDT Or hydraulic A	Solenoid Without LVDT or hydraulic B	Pilot-stage LVDT				Main-stage LVDT			
				Pin 1	Pin 2	Pin 3	Pin 4	Pin 1	Pin 2	Pin 3	Pin 4
KCG-3/6/8 and KX(C)G-6/8	EEA-PAM-513-B-33	b26/b28	-	-	-	-	-	-	-	-	-
K*G4V-3 and KDG5V-5/7/8	EEA-PAM-523-B/C-33	b26/b28	z26/z28	-	-	-	-	-	-	-	-
K*G4V-5	EEA-PAM-525-B/C-33	b26/b28	z26/z28	-	-	-	-	-	-	-	-
KF*G4V-3	EEA-PAM-533-B/C-33	b26/b28	z26/z28	-	-	-	Not connected	b14	z22	b16	Not connected
KF*G4V-5	EEA-PAM-535-B/C-33	b26/b28	z26/z28	-	-	-		b14	z22	b16	
KFDG5V-5/7	EEA-PAM-561-B/C-33	-	z26/z28	-	-	-	-	b14	z22	b16	-
KFDG5V-8	EEA-PAM-568-B/C-33	-	z26/z28	-	-	-	-	b14	z22	b16	-
CVU-**-EFP1	EEA-PAM-571-B-33	-	z26/z28	-	-	-	-	b14	z22	b16	-
KHDG5V-5/7/8	EEA-PAM-581-B-33	-	z26/z28	z14	z22	z16	-	b14	z22	b16	-

Note: If valves are fitted with the “E” type LVDT, the screen will be grounded at the valve end by the shell of the connector.

Type C amplifier with command logic module and 4 ramps

5. Fault diagnosis

If the amplifier fails to work the following checks should be made:

1. Check that all wiring is correct to the machine designer's instructions.
2. Check that there is a 24V supply and that the 24V LED is ON.
3. Check that the 15V internal voltage LED is ON (if 24V LED is ON and this 15V LED is OFF then the amplifier should be replaced.)
4. Check that the amplifier is enabled and the LED is ON.
5. Check that the LVDT failure LED is OFF. (If ON check the LVDT wiring and connections.)

To check correct function of the amplifier, disconnect all valve connections and link z22 (+15V) with a 1.2 k Ω resistor to b14. (To check the double feedback amplifiers EEA-PAM -581, make an additional link between z22 (+15V) and z14 with a 1.2 k Ω resistor.) After installation of resistor link(s), the LVDT failure LED should be OFF. If not, replace the amplifier (caution: a link without resistor damages the amplifier).

6. Check that the overload LED is OFF. (If ON, check the wiring to the solenoids and the solenoid resistance by an ohmmeter. Compare the measured value with the catalog data.)
7. Check that an appropriate command signal is applied (monitor point at the front panel)
 - $\pm 10V$ at monitor point represents $\pm 100\%$ output
8. The solenoid current (non-feedback valves) or the LVDT signal (feedback valves) can be measured at the front panel monitor point.
 - Solenoid current can be measured as a voltage signal (1 volt per amp)
 - $\pm 10V$ LVDT signal at monitor point represents $\pm 100\%$ stroke.

Type D Power amplifiers with PID modules

General description

The EEA-PAM -5**-D-33 Eurocards are power amplifiers with integrated PID modules. Each of these cards replaces two conventional electronic cards.

Features and benefits

- Includes all features of "A" amplifiers (except gain)
- User configurable PID feed-forward, closed-loop operation
- Command input ramps
- Analog feedback sensor interface
- Automatic switch-over p/Q function
- Built-in test feature

- The design reduces the amount of external wiring, saves space in the rack enclosure and requires only one 24V supply
- The general purpose, integrated module can be configured using DIL switches (D1-D9) and potentiometers for the following applications:
 - Closed-loop pressure control using either proportional pressure valves or servo-performance proportional valves
 - Closed-loop velocity control
 - Closed-loop position control
 - p/Q control with internal or external switch-over from Q to p
- The DIL-switch and potentiometer settings can easily be reconfigured on different cards
- CE electromagnetic compatibility.-2014/30/EU
- RoHS Compatibility-DIRECTIVE 2011/65/EU

Front panel

LEDs

- [1] 24V power supply input, green
- [2] 15V control supply output, green
- [3] Drive (solenoid) enabled, yellow
- [4] Overload, red
- [5] LVDT failure, red ●
- [6] Drive level to solenoid, yellow

Potentiometers

- [7] Deadband compensation, flow P to B ▲ ◆
- [8] Deadband compensation, flow P to A ▲ ◆

LED

- [9] Ramps enabled, yellow

Potentiometers

- [10] Command ramp up
- [11] Command ramp down

Monitor points ■

- [12] MP1: Conditioned command signal
- [13] Common ground (0V)
- [14] MP2: LVDT (spool) position ▼

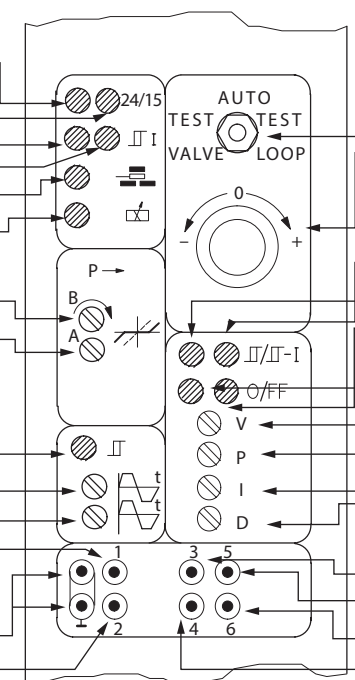

- [15] Mode switch
 - TEST VALVE setting
 - AUTO function setting
 - TEST LOOP setting
- [16] Test potentiometer

LEDs

- [17] PID-controller enabled, yellow
- [18] Integrator enabled, yellow
- [19] Feedback = command signal, green
- [20] Sensor failure, red

Potentiometers

- [21] Feed-forward signal scaling
- [22] P-gain
- [23] I-gain
- [24] D-gain

Monitor points ■

- [25] MP3: Command signal
- [26] MP5: PID-controller output
- [27] MP6: Integrator output
- [28] MP4: Feedback signal

▲ Number and function of potentiometers [7], [8], [7.2] vary according to model type as follows:

For models -513/541/553-

[7.2] Offset

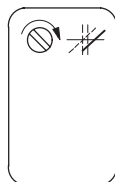

● LED and symbol not on EEA-PAM-513/523/525 amplifiers.

▼ Solenoid current for EEA-PAM-523/525-D models.

■ Ø2,0 mm (0.0787 " dia.) sockets.

◆ In the case of EEA-PAM-523/525-D models one of these relationships may not apply if two single solenoid valves are connected.

⚠ WARNING

Electromagnetic Compatibility (EMC)

It is necessary to ensure that the valve is wired up in accordance with the connection arrangements shown in this leaflet. For effective protection, the user's electrical cabinet, the valve subplate or manifold and the cable screens should be connected to efficient earth (ground) points. In all cases, both valve and cable should be kept as far away as possible from any source of electromagnetic radiation such as cables carrying heavy current, relays and certain kinds of portable radio transmitters, etc. Difficult environments could mean that extra screening may be necessary to avoid the interference.

Type D Power amplifiers with PID modules

Model codes

Table 18.

Amplifier model	For valves	
EEA-PAM-513-D-33	KCG-3, KCG-6/8	} With type "H" coils only
	KX(C)G-6/8	
EEA-PAM-523-D-33	K*G4V-3, KDG5V-5/7/8	
EEA-PAM-525-D-33	K*G4V-5	
EEA-PAM-533-D-33	KF*G4V-3	
EEA-PAM-535-D-33	KF*G4V-5	
EEA-PAM-541-D-33	KHDG5V-5/7/8 with zerolapped mainspool	
EEA-PAM-553-D-33	KSDG4V-3	
EEA-PAM-561-D-33	KFDG5V-5/7	
EEA-PAM-568-D-33	KFDG5V-8	
EEA-PAM-571-D-33	CVU-**-EFP1	
EEA-PAM-581-D-33	KHDG5V-5/7/8	

Operating data

Table 19.

Power (input) supply		See appropriate base amplifier, e.g. for EEA-PAM-535-D-33 see EEA-PAM-535-A-33
Control (output) supplies:	z22	+15V for LVDTs only
Reference voltages	z2	+10V x 5 mA
	b2	-10V x 5 mA
Analog inputs:		
Command signal inputs		
Direct-voltage pins	b6, b8, b10, z8	
Inverting-voltage input	z10	
Voltage range		± 10V
Input impedance (voltage)		47 kΩ
Current input	z6	
Current range		± 20 mA
Input impedance (current)		100Ω
Feed-forward input	d8	
Input impedance		6 kΩ
Voltage range		± 10V
Input to ramp generator	d28	
Input impedance		10 kΩ
Voltage range		± 10V
Inputs from sensors		
Voltage input	d2	
Input impedance		1 MΩ
Voltage range		0 to 10V, or ± 10V ■
Current input d2		
Input impedance		100Ω
Current range (See "DIL Switches" five pages on)		4-20 mA or 0-20 mA
Monitoring of sensor failure for sensors with a current output only		
■ The demand signal should have the same voltage range as the sensor feedback, i.e. 0 to 10V, or ± 10V.		
Digital inputs:		
Drive enable (power available to solenoid)	z24	
Ramps enable	b24	
Integrator enable	d14	⚠ Warning: In a power-up sequence, the integrator should not be enabled until all hydraulic, electric and control power and signals are applied and stable. Abrupt or unpredictable motion may occur if integrator is enabled during this transition time.

Operating data

Table 19. continued

PID-controller enable	d12	
Enabled		17 to 40V
Disabled		0 to 3.5V
Load current		≤ 10 mA
Digital outputs:		
Sensor failure	d18	
Sensor failure		V _{cc} -2V
Sensor o.k.		<3V
Load current (withstands a continuous short-circuit condition)		≤ 100 mA
This output may be used only in conjunction with sensors providing a current output (4-20 mA)		
Feedback = command signal	d10	
Feedback matches demand		V _{cc} -2V
Feedback does not match demand		<3V
Load current (withstands a continuous short-circuit condition)		≤ 100 mA
The load at pin d18 and pin d10 has to be connected to ground		
Analog outputs:		
PID-controller output	d4	
Error signal	d22	
Feedback signal	d24	
Load impedance		≥ 10 kΩ; short-circuit proof
Voltage range		± 10V
Output from ramp generator	d26	
Load resistance		≥ 5 kΩ; short-circuit proof
Voltage range		± 10V
Alarm output (drive output status):	z12	
Set alarm		Enable amplifier (on pin z24) >500 ms after switching power on.
Signal		HIGH when alarm is activated. Output = Supply volts minus 2 volts. I = 50 mA max. LOW when solenoid overload has occurred. (Maintained until reset). Output = 0 to +/-2 volts. Output resistance = 50 ohms.
Reset after failure		Disable and re-enable on pin z24.
Ramp active indicator:	b12	
Drive ramping up		Output > 10V
Drive ramping down		Output < - 10V
Drive not ramping		Output 0 ± 10V
Output resistance		10 kΩ
Drive signal zero indicator:	b20	
Drive signal at null (within deadband limits)		Output = Supply minus 1.5V; I = 50 mA max.
Drive active		Output = 0 ± 2V
Output resistance		50 Ω
Potentiometers:		
Feed-forward		V = 20% to 100%
P-gain (depends on DIL switch D2):		P = 0.1 to 50V/V
I-gain range		K _i = 0.5 to 100 V/s/V
D-gain range		K _d = 0 to 0.05 V/V/s
Sensor signal gain range ■		90% to 120%
Sensor signal offset range ■		± 10%

■ Located on PID module.

Type D Power amplifiers with PID modules

Operating data

Table 19. continued

Monitor points:		
Conditioned command signal	MP1	
LVDT (spool) position ▲	MP2	
Command signal	MP3	
Feedback signal	MP4	
PID-controller output	MP5	
Integrator output (100%, independent of D3, D4, D5)	MP6	
Voltage range		± 10V
Monitor point impedance		10 kΩ
Ambient conditions:		
Storage temperature range		-25 to +85 °C (-13 to +185°F)
Operating temperature range		0 to 50 °C (32 to 122 °F)
Mass		
Installation wiring requirements for Vickers electronic products		0.4 kg (0.88 lb) approx. 2468
Cardholder	F48	02-104808

▲ All amplifiers except EEA-PAM-523/525 models, in which solenoid current is monitored.

Type D Power amplifiers with PID modules

Circuit and Connections

EEA-PAM-5**-D-33

Note: Read circuit in conjunction with that for relevant base amplifier
EEA-PAM-5**-A

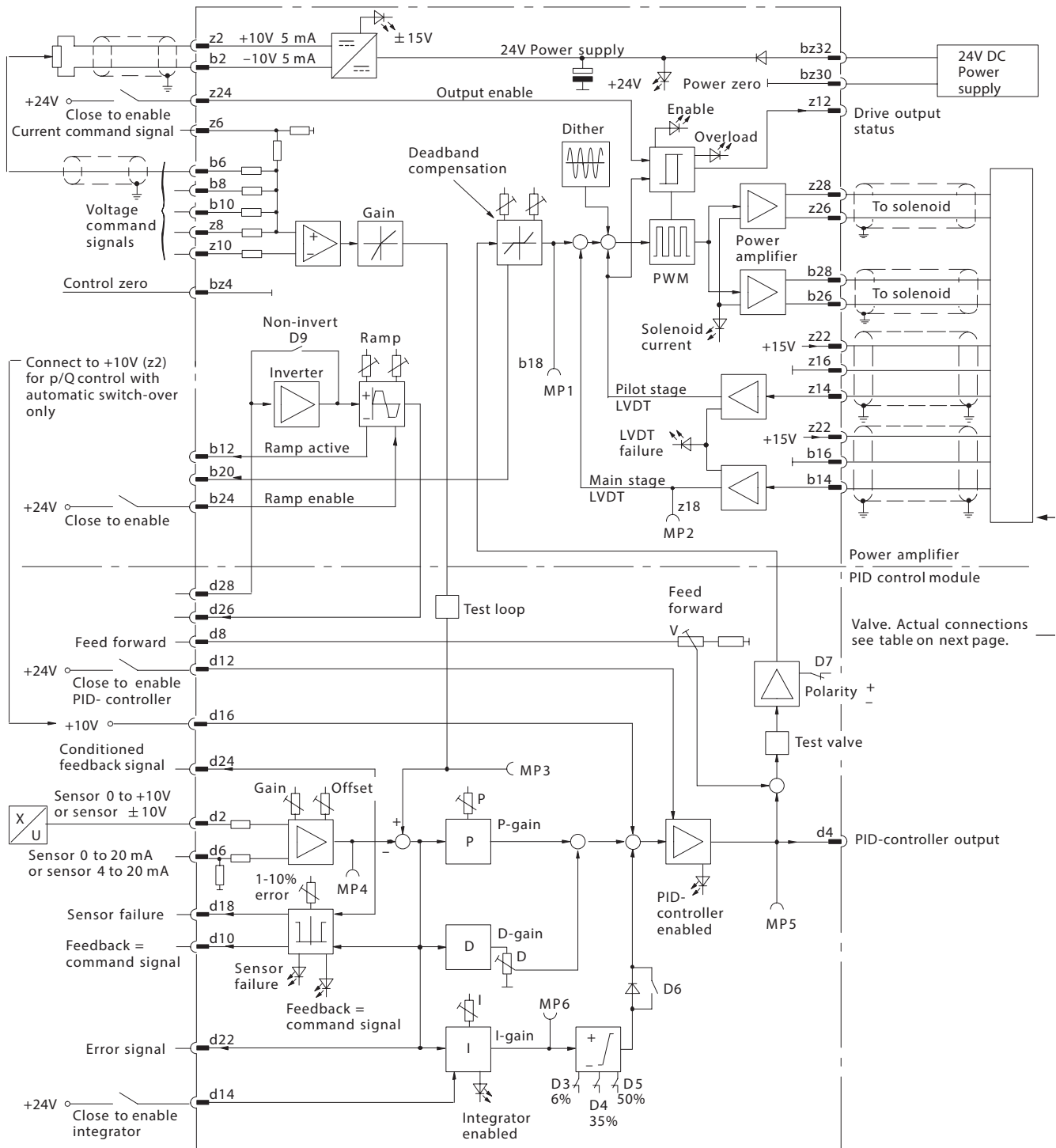

⊥ Customer's protective ground connection.

Type D Power amplifiers with PID modules

Solenoid and LVDT connections for proportional valves

Table 20.

Amplifier type	Solenoid with LVDT and/or for flow P to B	Solenoid without LVDT, or on pilot valve	Pilot-stage LVDT, (black plug):				Main-stage LVDT, (gray plug):			
			Pin 1	Pin 2	Pin 3	Pin 4	Pin 1	Pin 2	Pin 3	Pin 4
EEA-PAM-513-D-33	b26/b28	-	-	-	-	Not connected	-	-	-	Not connected
EEA-PAM-523-D-33	b26/b28	z26/z28	-	-	-	Not connected	-	-	-	Not connected
EEA-PAM-525-D-33	b26/b28	z26/z28	-	-	-	Not connected	-	-	-	Not connected
EEA-PAM-533-D-33	b26/b28	z26/z28	-	-	-	Not connected	b14	z22	b16	Not connected
EEA-PAM-535-D-33	b26/b28	z26/z28	-	-	-	Not connected	b14	z22	b16	Not connected
EEA-PAM-541-D-33	-	z26/z28	z14	z22	z16	Not connected	b14	z22	b16	Not connected
EEA-PAM-553-D-33	-	z26/z28	-	-	-	Not connected	b14	z22	b16	Not connected
EEA-PAM-561-D-33	-	z26/z28	-	-	-	Not connected	b14	z22	b16	Not connected
EEA-PAM-568-D-33	-	z26/z28	-	-	-	Not connected	b14	z22	b16	Not connected
EEA-PAM-571-D-33	-	z26/z28	-	-	-	Not connected	b14	z22	b16	Not connected
EEA-PAM-581-D-33	-	z26/z28	z14	z22	z16	Not connected	b14	z22	b16	Not connected

Installation dimensions in mm (inches)

Plug-in Unit of 3U height, to IEC 297

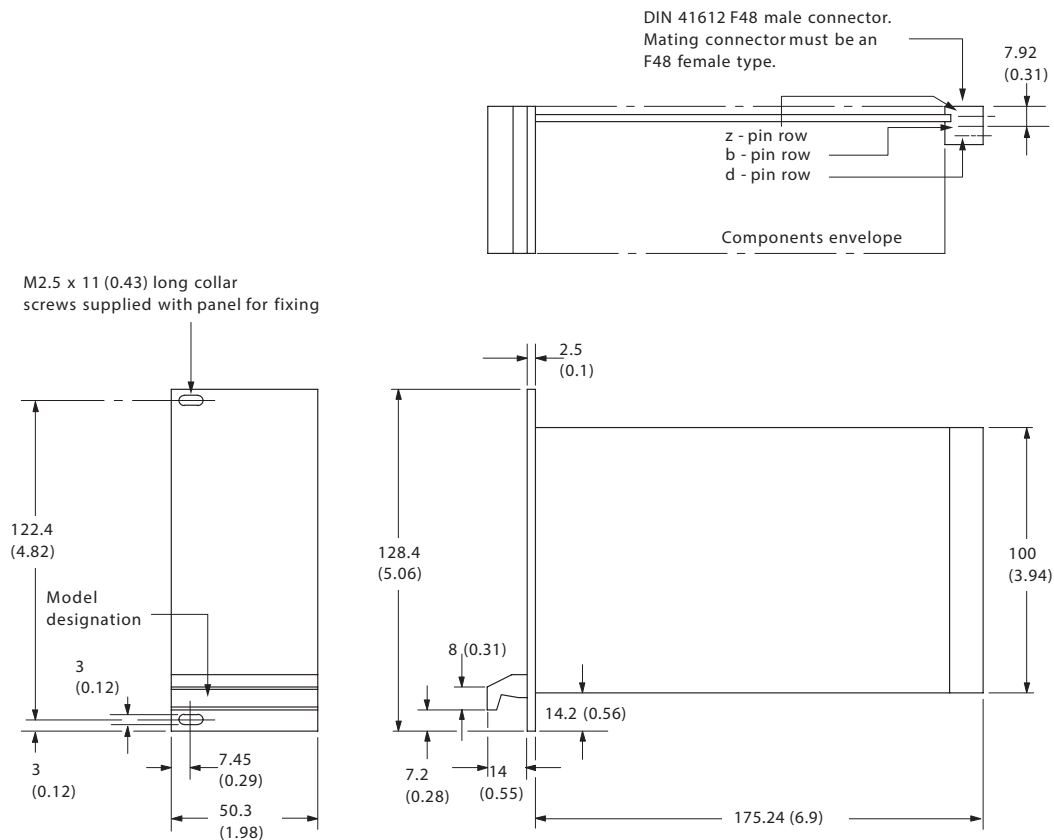

Application notes

DIL Switches

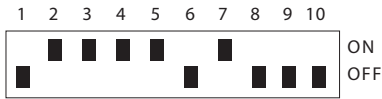

Factory setting

The controller is configured for the application using DIL switches, located on the board.

The DIL switch operates as follows:

Table 21.

Switch	On	Off
D1:	For sensors with 4 to 20 mA output	For sensors with $\pm 10V$ or 20 mA outputs
D2:	P-gain 2 to 50	P-gain 0,1 to 2
D6:	One-sided limitation of the integrator output. (Only useful for proportional pressure and proportional throttle valves.)	No limitations of integrator output
D7:	Inverts the controller output signal	Non-inverted signal
D8:	For sensors with 4 to 20 mA output	For sensors with $\pm 10V$ or 20 mA outputs
D9:	Ramp signal not inverted	Ramp signal inverted
D10:	Not used	-

For p/Q control with automatic switch-over, connect d16 to z2 (+10V). The flow command signal (Q) is applied to the feed-forward input, d8, and the desired pressure setpoint voltage applied to a command signal input (b6/8/10 or z6/8/10). The pressure feedback sensor is connected to the sensor input d2, or d6 as required. The pressure control loop will override the flow command to limit the pressure to the level determined by the pressure setpoint voltage. Adjust P, I and D gains for best performance.

The switches D3, D4 and D5 belong together. They limit the I-gain between 5% and 100% as follows:

D3	D4	D5	I-limit
ON	ON	ON	100%
ON	ON	OFF	50%
ON	OFF	ON	35%
ON	OFF	OFF	25%
OFF	ON	ON	5.9%
OFF	ON	OFF	5.8%
OFF	OFF	ON	5.3%
OFF	OFF	OFF	5.0%

Operation of the integrated test mode

The basic operation of the hydraulic actuator can be tested by using the 3-position mode switch mounted on the front panel. To select different modes the toggle switch must be lifted slightly before turning it to a new position.

CAUTION

Before setting the mode switch to either "Test valve" or "Test loop" make sure the test potentiometer is set to "0". Otherwise sudden movements of the actuator may occur.

The mode switch has three positions:

Auto

The controller operates in closed-loop mode, using the external command signal. The test potentiometer is disconnected.

Test valve

An open-loop command signal for the valve comes directly from the potentiometer. The external input signal is disconnected. The hydraulic part of the system may be tested in this configuration.

Test loop

The closed-loop command signal for the PID-controller comes directly from the potentiometer. The external signal input is disconnected. This configuration allows for verification of the valve polarity and the control parameters.

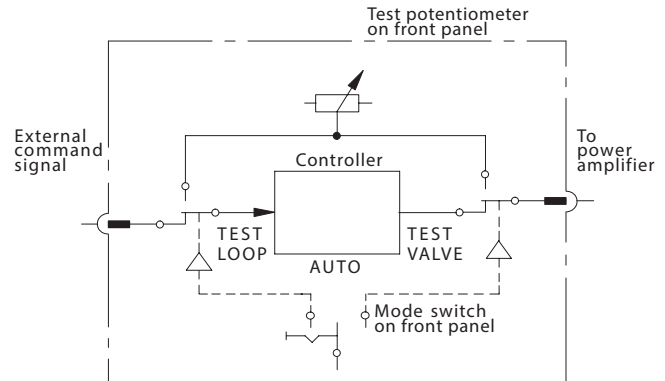

Type D Power amplifiers with PID modules

Dedicated installation recommendation for Card Type D

Pre-installation checks:

1. The controller has to be configured for the application by the DIL switches. When replacing an existing amplifier, set the DIL switches in the same position as the old amplifier

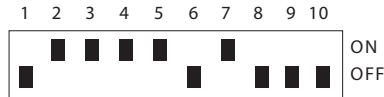

Wiring sizes

1. Use 3-core screened cable $\geq 0.5 \text{ mm}^2$ (20 AWG) per wire for signal and LVDT wiring.
2. For wiring runs between amplifier and solenoid up to 25 metres (82 ft), use wire of $\geq 1 \text{ mm}^2$ (18 AWG) cross-section.

Installation requirements according to European EMC regulations

1. The screen for LVDT wiring has to be connected to protective earth at both ends. PIN 4 on the LVDT plug is connected to LVDT housing. Alternatively, double screened cable can be used with two screens grounded at opposite ends.

Front panel controls

Any of the following controls may be on the front panel (depending on the amplifier type) and can be adjusted as described.

1. Set zero:

On amplifier types 513, 541 and 553 this sets the electrical null of the valve

2. Deadband compensation:

(not available on types 513, 541 and 553)

The two potentiometers are factory set at 10% (20% for types 523 and 533) of valve maximum spool stroke. The setting may be optimized for your application as follows:

Apply a small command signal (e.g. 250 mV) and check for hydraulic response from the valve. (For 2-stage valves the correct pilot pressure must be available to obtain response from the main-stage spool.) If this does not occur then adjust the applicable potentiometer clockwise until it does. Alternatively, to reduce valve hydraulic response turn the potentiometer counter-clockwise.

3. Ramps

The ramp generator is available as a separate unit and can be used to ramp the command signal. The factory settings of ramp potentiometers are minimum ramp time. Turning the controls clockwise increases ramp time, turning counter-clockwise decreases ramp time.

4. PID controller

The adjustment of the PID controller must be done by a qualified person with knowledge of closed loop systems. Adjust the controls V, P, I, D to achieve optimum performance of the closed loop system.

5. Integrated Test Unit

The basic operation of the valve, the hydraulic actuator and the whole closed loop system can be tested by using the integrated test facilities on the front panel.

Caution: Before setting the mode switch to either "Test valve" or "Test loop", make sure the test potentiometer is set to "0". Otherwise sudden movements of the actuator may occur.

Reconfiguration of controller parameters

Once the controller parameters have been optimized and set, they can be measured by means of an ohmmeter. This allows an easy reconfiguration of the controller on different cards for use as spare parts or on standard machine series. Four test points are located on the PID module for this purpose, see diagram for locations. The resistance between the appropriate test point and ground (at the front panel monitor point) determines the controller parameters:

- P = P-gain
- I = I-gain
- D = D-gain
- V = Feed-forward gain

Location of User Features on PID Module

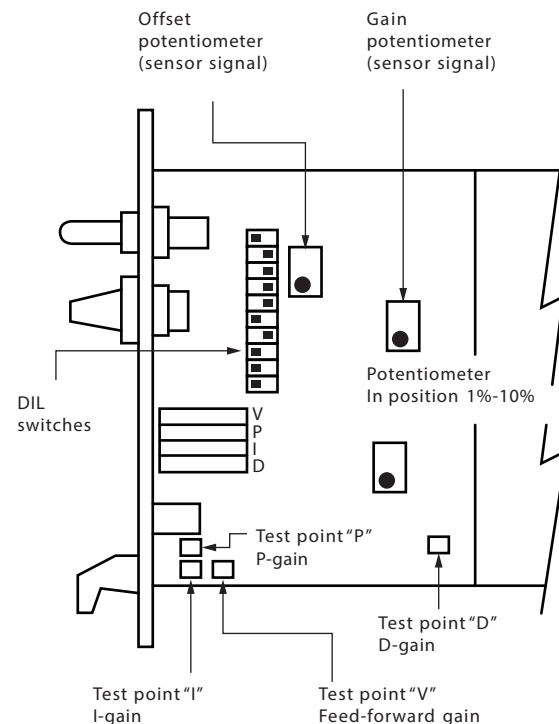





Type D Power amplifiers with PID modules

Front panel indicator lights (LEDs)

Amplifiers may have some, or all, of the following LEDs, depending on amplifier type:

Table 22.

Panel symbol	Function indicated	Color	Normal working state
24V	Power supply ON	Green	ON
15V	Internal supply ON	Green	ON
	Output enabled	Yellow	ON
	Overload detection	Red	OFF
	LVDT failure	Red	OFF
	Ramps enabled	Yellow	ON
	Current to solenoid (Light intensity varies with solenoid current)	Yellow	ON

Fault diagnosis:

If the amplifier fails to work the following checks should be made

1. Check that all wiring is correct to the machine designer's instructions
2. Check that there is a 24V supply and that the 24V LED is ON
3. Check that the 15V internal voltage LED is ON (if 24V LED is ON and this 15V LED is OFF then the amplifier should be replaced.)
4. Check that the amplifier is enabled and the LED is ON

Valve connection table

This table shows how the different valves have to be connected to the associated amplifier.

Table 23.

Value type	Amplifier type	Solenoid with LVDT or hydraulic A	Solenoid without LVDT or hydraulic B	Pilot-stage LVDT				Main-stage LVDT			
				Pin 1	2	3	4	Pin 1	2	3	4
KCG-3/6/8 and KX(C)G-6/8	EEA-PAM-513-D-33	b26/b28	-	-	-	-	-	-	-	-	-
K*G4V-3 and KDG5V-5/7/8	EEA-PAM-523-D-33	b26/b28	z26/z28	-	-	-	-	-	-	-	-
K*G4V-5	EEA-PAM-525-D-33	b26/b28	z26/z28	-	-	-	-	-	-	-	-
KF*G4V-3	EEA-PAM-533-D-33	b26/b28	z26/z28	-	-	-	-	b14	z22	b16	-
KF*G4V-5	EEA-PAM-535-D-33	b26/b28	z26/z28	-	-	-	-	b14	z22	b16	-
KHDG5V-5/7/8 zero lapped	EEA-PAM-541-D-33	-	z26/z28	z14	z22	z16	Screen	b14	z22	b16	Screen
KSDG4V-3	EEA-PAM-553-D-33	-	z26/z28	-	-	-	-	b14	z22	b16	-
KFDG5V-5/7	EEA-PAM-561-D-33	-	z26/z28	-	-	-	-	b14	z22	b16	-
KFDG5V-8	EEA-PAM-568-D-33	-	z26/z28	-	-	-	-	b14	z22	b16	-
CVU-**-EFP1	EEA-PAM-571-D-33	-	z26/z28	-	-	-	-	b14	z22	b16	-
KHDG5V-5/7/8	EEA-PAM-581-D-33	-	z26/z28	z14	z22	z16	-	b14	z22	b16	-

5. Check that the LVDT failure LED is OFF. (If ON check the LVDT wiring and connections.)

To check correct function of the amplifier, disconnect all valve connections and link z22 (+15V) with a 1.2 kΩ resistor to b14. (To check the double feedback amplifiers EEA-PAM-581/541, make an additional link between z22 (+15V) and z14 with a 1.2 kΩ resistor.)

After installation of resistor link(s), the LVDT failure LED should be OFF. If not, replace the amplifier (caution: a link without resistor damages the amplifier).

6. Check that the overload LED is OFF. (If ON, check the wiring to the solenoids and the solenoid resistance by an ohmmeter. Compare the measured value with the catalog data.)
7. Check that an appropriate valve driving signal is available (monitor point MP1 at the front panel).
 - ±10V at monitor point represents ±100% output of the valve
8. The solenoid current (non-feedback valves) or the LVDT signal (feedback valves) can be measured at the front panel monitor point MP2.
 - Solenoid current can be measured as a voltage signal (1 volt per amp)
 - ±10V LVDT signal at monitor point represents ±100% stroke
9. Check that the DIL switches are set correctly, corresponding to the application.
10. Check the PID controller operation by using the monitor points MP3, 4,5,6 at the front panel. The integrated test facility is a support to check the operation.

Type E Power amplifiers with strip guidance controller modules

EEA-PAM-5**-E-33 Series

General description

A strip guidance controller serves to control the position of an electrohydraulic actuator, using optical sensors.

The controller can be used for strip-edge or strip-center guidance or stack height control.

It consists of a power amplifier for proportional valves, and an integrated module for strip guidance control.

Features and benefits

- Includes all features of "A" amplifiers (except gain)
- Input offset compensation
- Strip guidance control
- Voltage or current input sensor interface
- Built-in test feature
- CE electromagnetic compatibility.- 2014/30/EU
- RoHS Compatibility-DIRECTIVE 2011/65/EU

Front panel

LEDs

- [1] 24V power supply input, green
- [2] 15V control supply output, green
- [3] Drive (solenoid) enabled, yellow
- [4] Overload, red
- [5] LVDT failure, red
- [6] Drive level to solenoid, yellow

Potentiometers

- [7] Deadband compensation, flow P to B
- [8] Deadband compensation, flow P to A

LED

- [9] Ramps enabled, yellow

Potentiometers

- [10] Acceleration ramp
- [11] Deceleration ramp

Monitor points ■

- [12] MP1: Conditioned input signal
- [13] Common ground (0V)
- [14] MP2: LVDT (spool) position ▲

- ▲ Solenoid current for EEA-PAM-523/525-E models.
- Ø2,0 mm (0.0787 "dia.) sockets.

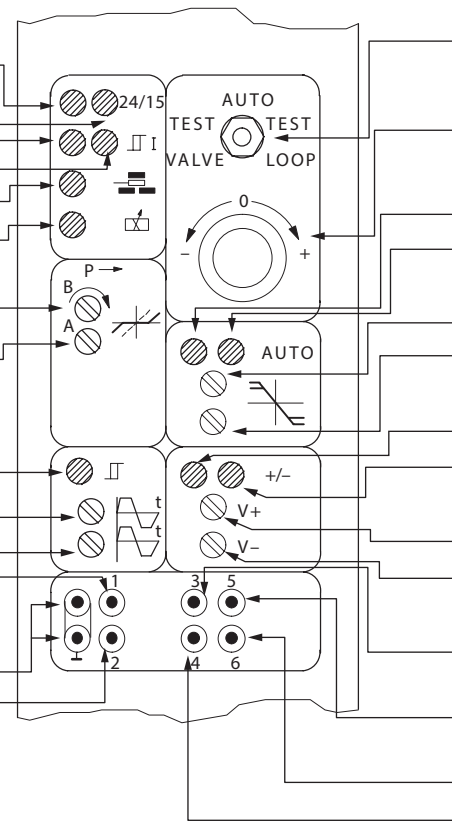

- [15] Mode switch
 - TEST VALVE setting
 - AUTO function setting
 - TEST LOOP setting

- [16] Test potentiometer

LEDs

- [17] Controller active, yellow
- [18] Sensor out of range, red

Potentiometers

- [19] Maximum closed-loop velocity +
- [20] Maximum closed-loop velocity -

LEDs

- [21] Open-loop command (+) active
- [22] Open-loop command (-) active

Potentiometers

- [23] Open-loop command +
- [24] Open-loop command -

Monitor points ■

- [25] MP3: Output signal of sensor with current output, non-inverting
- [26] MP5: Conditioned sensor signal, ± 10V full scale
- [27] MP6: Controller output
- [28] MP4: Output signal of sensor with current output, inverting

⚠ WARNING

Electromagnetic Compatibility (EMC)

It is necessary to ensure that the valve is wired up in accordance with the connection arrangements shown in this leaflet. For effective protection, the user's electrical cabinet, the valve subplate or manifold and the cable screens should be connected to efficient earth (ground) points. In all cases, both valve and cable should be kept as far away as possible from any source of electromagnetic radiation such as cables carrying heavy current, relays and certain kinds of portable radio transmitters, etc. Difficult environments could mean that extra screening may be necessary to avoid the interference.

Type E Power amplifiers with strip guidance controller modules

Operation

Non-contact optical sensors measure the position of the strip edge. The output from a sensor is an electrical signal, which is fed to the strip guidance controller (signal ranges 0 to 20 mA, 4 to 20 mA, 0 to +10V, or 0 to +24V). When activated, the strip guidance controller maintains the strip edge exactly in the center of the measuring range.

If the position of the strip edge deviates from the center of the measuring range, the controller causes the actuator to move the strip edge back into position.

When closed-loop control is activated by the digital input signal "Automatic", the strip edge is moved from its current position into the measuring range of the sensor. The maximum actuator velocity (forwards and reverse) can be set on the front panel. Whenever the strip edge leaves the measuring range of the sensor, the controller generates a digital output signal which can be processed by the machine controller.

If closed-loop control is not activated, the controller can be operated open-loop. In this case the actuator travels at the velocity set by potentiometer "V+" when digital input "set +" is activated. "V -" and digital input "set -" are used for movements in the reverse direction.

A built-in test function together with front panel monitor points, considerably simplify start-up and fault diagnosis.

Model codes

Table 24.

Amplifier model	For valves	
EEA-PAM-523-E-33	KDG4V-3 and KDG5V-5/7/8	} With type "H" coils only
EEA-PAM-525-E-33	KDG4V-5	
EEA-PAM-533-E-33	KFDG4V-3	
EEA-PAM-535-E-33	KFDG4V-5	
EEA-PAM-541-E-33	KHDG5V-5/7/8 zero-lap	
EEA-PAM-553-E-33	KSDG4V-3	
EEA-PAM-561-E-33	KFDG5V-5/7	
EEA-PAM-568-E-33	KFDG5V-8	
EEA-PAM-581-E-33	KHDG5V-5/7/8	

Operating data

Table 25.

Power supply	zbd32	See appropriate base amplifier, e.g. for EEA-PAM-535-E-33 see EEA-PAM-535-A-33
Control (output) supplies:	z22	+15V for LVDTs only
Differential inputs for sensor:		
Voltage input, non-inverting	d2	+24V max., $R_i = 100\text{ k}\Omega$
Voltage input, inverting	d6	24V max., $R_i = 100\text{ k}\Omega$
Current input, non-inverting	d8	20 mA max., $R_i = 100\Omega$
Current input, inverting	d12	20 mA max., $R_i = 100\Omega$
Digital inputs (opto-isolated):		
Set +	d22	24V DC nom, 20 to 40V DC max., $R_i = 2.7\text{ k}\Omega$
Set -	d20	24V DC nom, 20 to 40V DC max., $R_i = 2.7\text{ k}\Omega$
Automatic	d18	24V DC nom, 20 to 40V DC max., $R_i = 2.7\text{ k}\Omega$
Drive enable	z24	Enable = 9.8 to 40V Disable = 0 to 4.8V or open, $R_i = 47\text{ k}\Omega$
Ramp enable	b24	Enable = 9.8 to 40V Disable = 0 to 4.8V or open, $R_i = 47\text{ k}\Omega$
Digital output (opto-isolated):		
Out of range	d24	24V DC nom. Short-circuit proof. $I_{max} = 100\text{ mA}$
Potentiometers:		
Deadband compensation		Separate controls for each direction from spool-centered position 0 to 50% of max. current
Ramp time adjustment		Separate controls for acceleration and deceleration 50 ms to 5 sec
Closed-loop velocities		Separate controls for forward and reverse 5 to 100%
Open-loop command		Separate controls for forward and reverse 0 to 100%
Monitor points		
(Numbers corresponding to the numbering on the front panel and in the circuit diagram)		MP1: Conditioned input signal, $\pm 10\text{V}$ MP2: LVDT (spool) position, $\pm 10\text{V}$ ▲ MP3: Output signal of sensor with current output, non-inverting 0 to 2V = 0 to 20 mA MP4: Output signal of sensor with current output, inverting 0 to 2V = 0 to 20 mA MP5: Conditioned sensor signal, $\pm 10\text{V}$ MP6: Controller output, $\pm 10\text{V}$ All monitor points are short-circuit proof. In all cases: $R(\text{out}) = 10\text{ k}\Omega$

▲ Solenoid current for EEA-PAM-523/525-E models.

Type E Power amplifiers with strip guidance controller modules

Table 25. continued

Alarm output:	z12	
Set alarm		Enable amplifier (on pin z24) when switching power on
Signal		HIGH when alarm is activated Output = Supply volts minus 2 volts I = 50 mA max. LOW when solenoid overload has occurred. (Maintained until reset) Output = 0 to +/-2 volts Output resistance = 50 ohms
Reset after failure		Disable and re-enable on pin z24
Test facilities		3-position switch for: – Valve test mode – Controller test mode – Automatic operation mode Caution: Before setting the modeswitch to either “Test valve” or “Test loop” ensure that the test potentiometer is set to “0”, otherwise sudden movements of the actuator may occur.
Operating temperature		0 to 50 °C (32 to 122 °F)
Storage temperature		-25 to +85 °C (-13 to +185 °F)
Mass		0.4 kg (0.88 lb) approx.
Installation wiring requirements for Vickers electronic products		2468
Cardholder	F48	02-104808

Type E Power amplifiers with strip guidance controller modules

Circuit and Connections

EEA-PAM-533/535-E-33 example ▲

Note: Read circuit in conjunction with that for relevant base amplifier EEA-PAM-5**-A

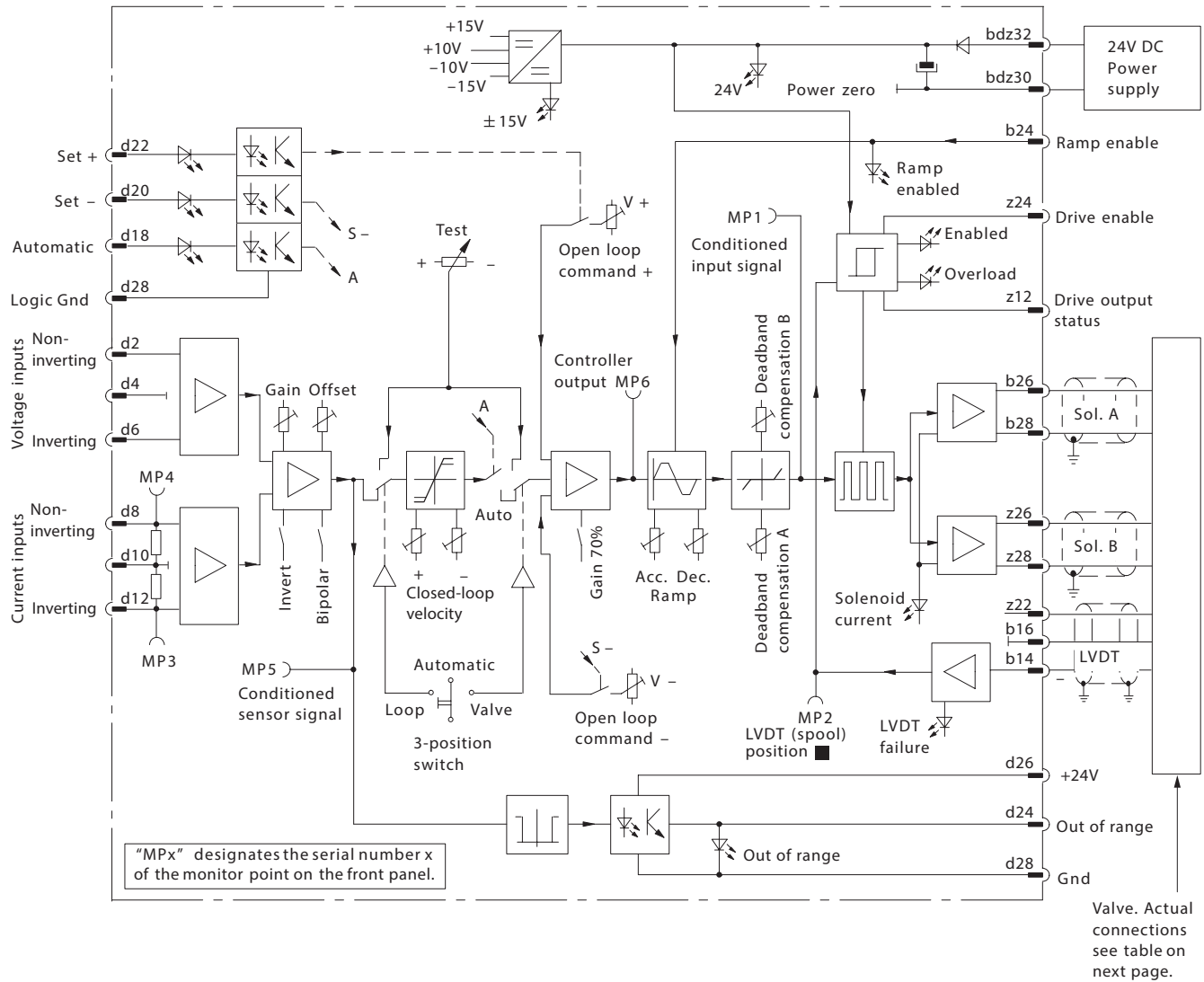

⏏ Customer's protective ground connection.

▲ See footnote at bottom of “Application Examples”

■ Solenoid current for EEA-PAM-523/525-E models.

Type E Power amplifiers with strip guidance controller modules

Solenoid and LVDT connections for proportional valves

Table 26.

Amplifier type	Solenoid with LVDT and/or for flow P to B	Solenoid without LVDT, or on pilot valve	Pilot-stage LVDT, (black plug):				Main-stage LVDT, (gray plug):			
			Pin 1	Pin 2	Pin 3	Pin 4	Pin 1	Pin 2	Pin 3	Pin 4
EEA-PAM-523-E-33	b26/b28	z26/z28	-	-	-	Not connected	-	-	-	Not connected
EEA-PAM-525-E-33	b26/b28	z26/z28	-	-	-	Not connected	-	-	-	Not connected
EEA-PAM-533-E-33	b26/b28	z26/z28	-	-	-	Not connected	b14	z22	b16	Not connected
EEA-PAM-535-E-33	b26/b28	z26/z28	-	-	-	Not connected	b14	z22	b16	Not connected
EEA-PAM-541-E-33	-	z26/z28	z14	z22	z16	Not connected	b14	z22	b16	Not connected
EEA-PAM-553-E-33	-	z26/z28	-	-	-	Not connected	b14	z22	b16	Not connected
EEA-PAM-561-E-33	-	z26/z28	-	-	-	Not connected	b14	z22	b16	Not connected
EEA-PAM-568-E-33	-	z26/z28	-	-	-	Not connected	b14	z22	b16	Not connected
EEA-PAM-581-E-33	-	z26/z28	z14	z22	z16		b14	z22	b16	Not connected

Installation dimensions in mm (inches)

Plug-in Unit of 3U Height, to IEC 297

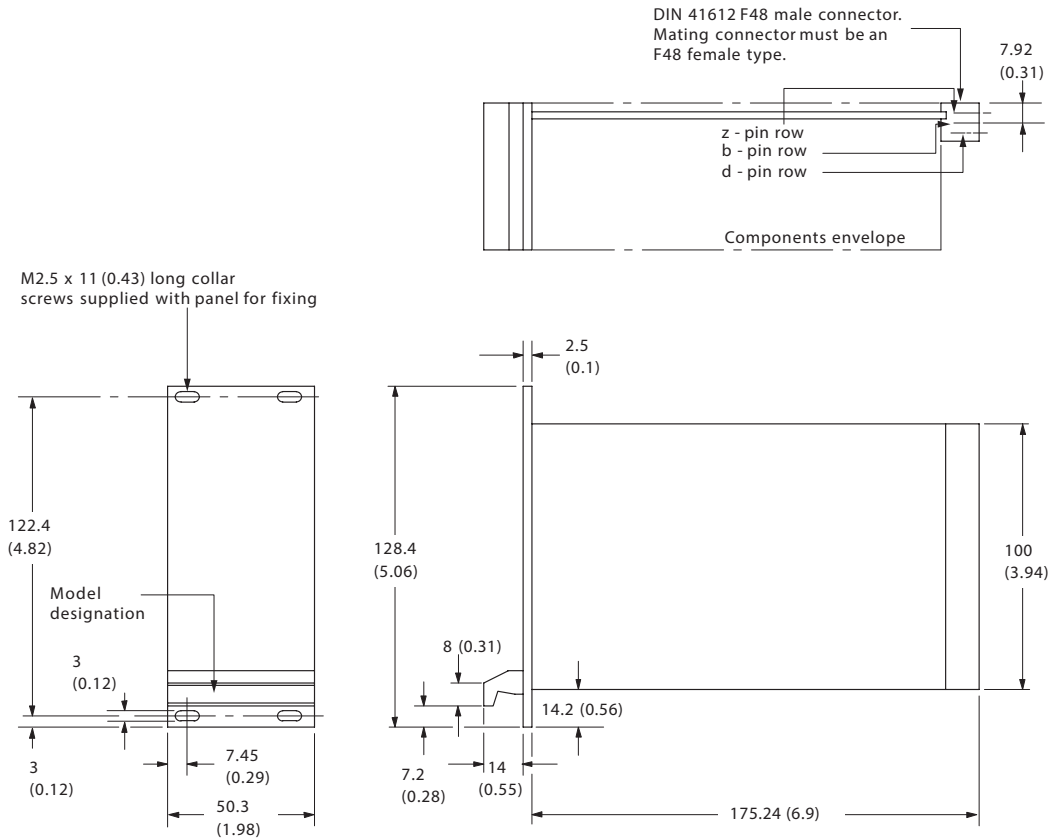

Type E Power amplifiers with strip guidance controller modules

Application examples

EEA-PAM-533/535-E amplifiers with KFDG4V-3/5 valves ▲

Strip guidance control, stack height control

Position sensor with current output

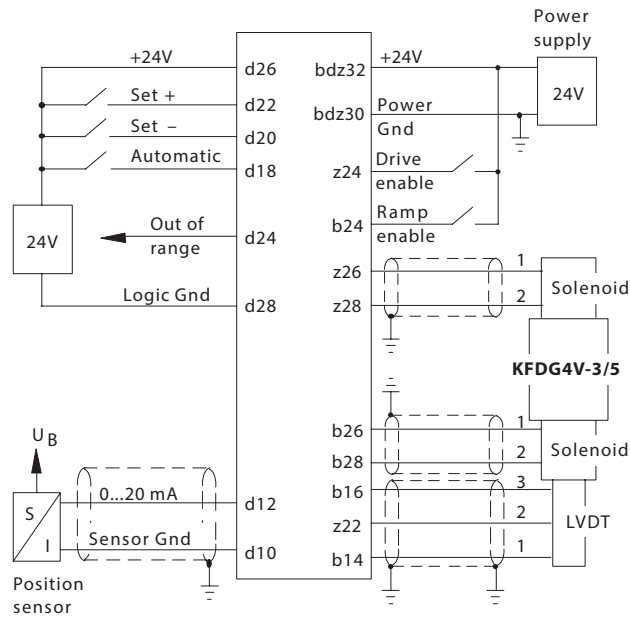

Position sensor with voltage output

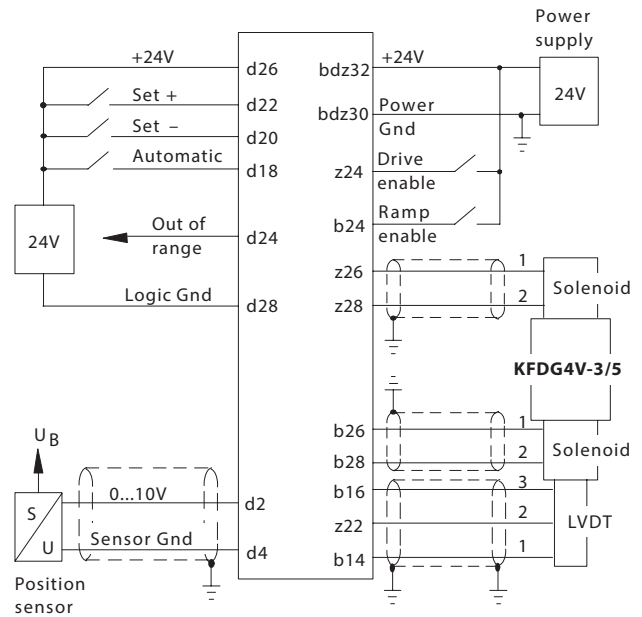

Strip-center guidance control

Position sensor with current output

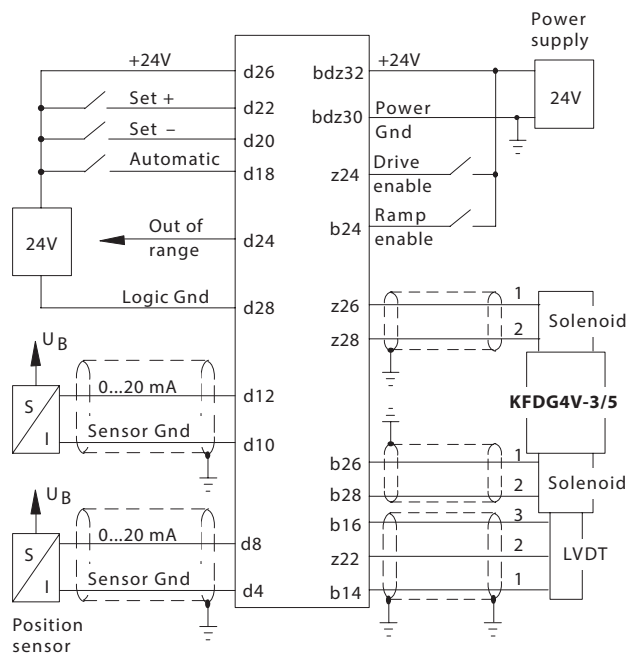

Position sensor with voltage output

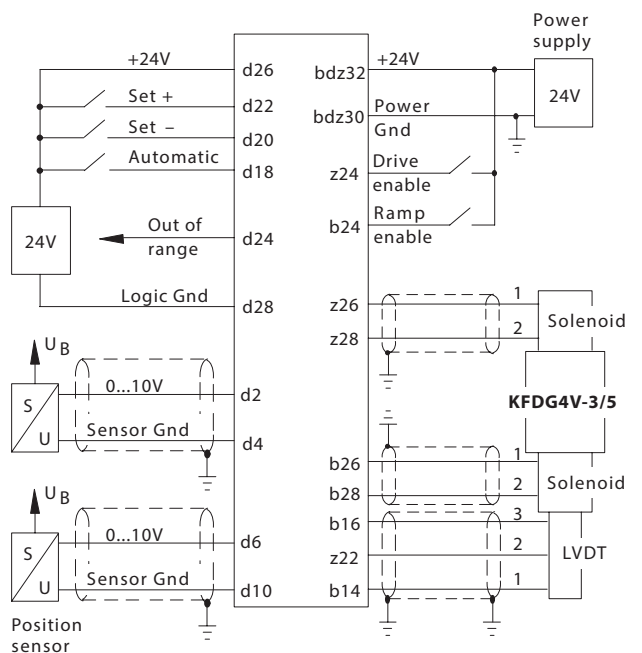

▲ Other amplifier/valve combinations differ in respect to the LVDT and solenoid connections; see catalog 2464 for the relevant base amplifier EEA-PAM-5**-A-33.

⏏ Customer's protective ground connection.

Type E Power amplifiers with strip guidance controller modules

Dedicated installation recommendation for Type E card

The operation of this amplifier has been factory-checked before dispatch as meeting the specification shown in this catalog

1. Configuration

The controller has to be configured for the application by the DIL switches. When replacing an existing amplifier, set the DIL switches in the same positions as the old amplifier.

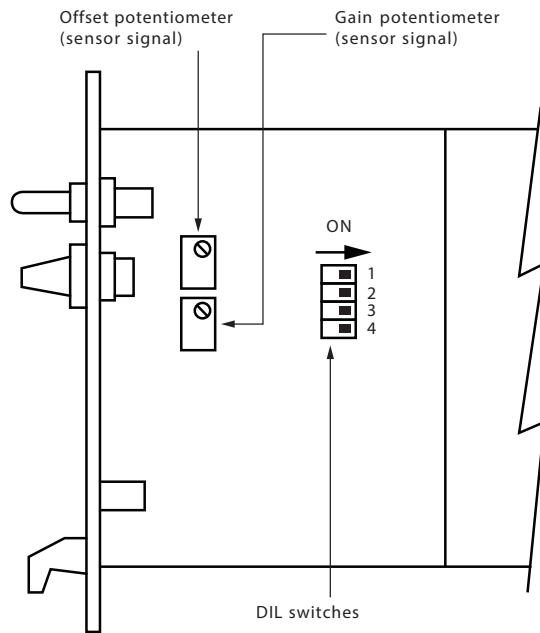

1	On	0-10V or 0-20 mA sensor signal
	Off	$\pm 5V$ or $\pm 10V$ or 2 sensors
2	On	Non-inverted sensor signal
	Off	Inverted sensor signal
3	On	KDG4V-3/5 or KFDG4V-3/5 valves
	Off	KSDG4V-3 or KFDG5V or KHDG5V valves
4		Not connected

2. Wiring sizes

Use 3-core screened cable $\geq 0.5 \text{ mm}^2$ (20 AWG) per wire for signal and LVDT wiring.

For wiring runs between amplifier and solenoid up to 25 meters (82 ft), use wire of $\geq 1 \text{ mm}^2$ (18 AWG) cross-section.

3. Sensor calibration

The amplifier is factory-set to suit a sensor with a 0-20 mA output.

Set the sensor signal to minimum (by covering) and adjust the "offset" potentiometer to read $-10V \pm 1\%$ at monitor point 5 (MP5).

Set the sensor signal to maximum (fully illuminated) and adjust the "gain" potentiometer to read $+10V \pm 1\%$ at MP5 on the front panel.

Re-check offset and repeat above as necessary.

4. Front panel controls

Any of the following controls may be on the front panel (depending on the amplifier type) and can be adjusted as described.

a. Set zero:

On amplifier types 541 and 553 this sets the electrical null of the valve

b. Deadband compensation:

(not available on types 541 and 553)

The two potentiometers are factory set at 10% (20% for types 523 and 533) of valve maximum spool stroke. The setting may be optimized for your application as follows:

Apply a small command signal (e.g. 250 mV) and check for hydraulic response from the valve. (For 2-stage valves the correct pilot pressure must be available to obtain response from the main-stage spool.) If this does not occur then adjust the applicable potentiometer clockwise until it does. Alternatively, to reduce valve hydraulic response turn the potentiometer counter-clockwise.

Type E Power amplifiers with strip guidance controller modules

c. Ramps

The ramp generator is available as a separate unit and can be used to ramp the command signal. The factory settings of ramp potentiometers are minimum ramp time. Turning the controls clockwise increases ramp time, turning counter-clockwise decreases ramp time.

d. Integrated test unit

The basic operation of the valve, the hydraulic actuator and the whole closed loop system can be tested by using the integrated test facilities on the front panel.

Note: to select different modes, the toggle switch must be lifted slightly before moving to a new position.

Caution: Before setting the mode switch to either "Test valve" or "Test loop", make sure the test potentiometer is set to "0". Otherwise sudden movements of the actuator may occur.

e. Test valve

With the 3-position switch set to "Test valve", ensure that the front panel test potentiometer controls the actuator speeds in both directions.

f. Auto

In this mode, the controller operates in closed loop using the external sensor signal. The test potentiometer is disconnected.

g. Test Loop

The test potentiometer can be used to simulate the sensor signal. The external sensor signal is disconnected.

h. Open loop command potentiometers

These are used to set the velocity when pin 20 or pin 22 are used by the machine controller to move the actuator.





i. Max. Closed loop velocity potentiometers

These are used to set the maximum velocity when in "Auto" mode.

5. Front panel indicator lights (LEDs)

Amplifiers may have some, or all, of the following LEDs, depending on amplifier type:

Table 27.

Panel symbol	Function indicated	Color	Normal working state
24V	Power supply ON	Green	ON
15V	Internal supply ON	Green	ON
	Output enabled	Yellow	ON
	Overload detection	Red	OFF
	LVDT failure	Red	OFF
	Ramps enabled	Yellow	ON
	Current to solenoid (Light intensity varies with solenoid current)	Yellow	ON

6. Fault diagnosis

If the amplifier fails to work the following checks should be made:

- Check that all wiring is correct to the machine designer's instructions.
- Check that there is a 24V supply and that the 24V LED is ON.
- Check that the 15V internal voltage LED is ON (if 24V LED is ON and this 15V LED is OFF then the amplifier should be replaced.)
- Check that the amplifier is enabled and the LED is ON.
- Check that the LVDT failure LED is OFF. (If ON check the LVDT wiring and connections.)
 - To check correct function of the amplifier, disconnect all valve connections and link z22 (+15V) with a 1.2 kΩ resistor to b14. (To check the double feedback amplifiers EEA-PAM-581/541, make an additional link between z22 (+15V) and z14 with a 1.2 kΩ resistor.) After installation of resistor link(s), the LVDT failure LED should be OFF. If not, replace the amplifier (caution: a link without resistor damages the amplifier).
- Check that the overload LED is OFF. (If ON, check the wiring to the solenoids and the solenoid resistance by an ohmmeter. Compare the measured value with the catalog data.)
- Check that the "automatic" signal is applied to pin d18.
- The solenoid current (non-feedback valves) or the LVDT signal (feedback valves) can be measured at the front panel monitor point MP2.
 - Solenoid current can be measured as a voltage signal (1 volt per amp)
 - ±10V LVDT signal at monitor point represents ± 100% stroke.

Note: Due to the effect of spool overlap, the working range is typically 3 to 9 volts for the flows from zero to maximum.
- Check the DIL switches are set correctly, corresponding to the application.
- Check the sensor output signals on MP3, MP4 or MP5 as appropriate.

Type E Power amplifiers with strip guidance controller modules

7. Valve connection table

This table shows how the different valves have to be connected to the associated amplifier.

Table 28.

Value type	Amplifier type	Solenoid with LVDT or hydraulic A	Solenoid without LVDT or hydraulic B	Pilot stage LVDT				Main stage LVDT			
				Pin 1	2	3	4	Pin 1	2	3	4
K*G4V-3 and KDG5V-5/7/8	EEA-PAM-523-E-33	b26/b28	z26/z28	-	-	-		-	-	-	
K*G4V-5	EEA-PAM-525-E-33	b26/b28	z26/z28	-	-	-		-	-	-	
KF*G4V-3	EEA-PAM-533-E-33	b26/b28	z26/z28	-	-	-		b14	z22	b16	
KF*G4V-5	EEA-PAM-535-E-33	b26/b28	z26/z28	-	-	-	Not connected	b14	z22	b16	Not connected
KHDG5V-5/7/8 zero lapped	EEA-PAM-541-E-33	-	z26/z28	z14	z22	z16		b14	z22	b16	
KSDG4V-3	EEA-PAM-553-E-33	-	z26/z28	-	-	-		b14	z22	b16	
KFDG5V-5/7	EEA-PAM-561-E-33	-	z26/z28	-	-	-		b14	z22	b16	
KFDG5V-8	EEA-PAM-568-E-33	-	z26/z28	-	-	-		b14	z22	b16	
KHDG5V-5/7/8	EEA-PAM-581-E-33	-	z26/z28	z14	z22	z16		b14	z22	b16	

Note: If valves are fitted with the "B" type LVDT, the screen will be grounded at the valve end by the shell of the connector.

Type F Power Amplifiers with CNC Adaptation Modules

EEA-PAM-5**-F-33 Series

General description

The EEA-PAM -5**-F-33 Eurocards are power amplifiers with integrated CNC adaptation modules. Each card replaces two conventional electronic cards. These power amplifiers are used for high accuracy positioning systems with inexpensive standard proportional valves and CNC axis or PLC position controls.

Features and benefits

- Includes all features of "A" amplifiers
- Hysteresis compensation for valves with/without feedback
- Enhanced deadband adjustment for closed-loop position control using valves with overlap
- This particular configuration reduces the amount of external wiring, saves space in the rack enclosure and requires only one 24V power supply
- Smooth transition between the overlap region and working region
- Low cost, high accuracy positioning systems with overlapped proportional valves. Non-linearities and inconsistencies (friction) in the overlap region are compensated by the electronic linearization
- Simple set-up procedure
- A built-in test function significantly simplifies commissioning (start-up) and fault-diagnosis
- CE electromagnetic compatibility.- 2014/30/EU
- RoHS Compatibility-DIRECTIVE 2011/65/EU

Front panel

LEDs

- [1] 24V power supply input, green
- [2] 15V control supply output, green
- [3] Drive (solenoid) enabled, yellow
- [4] Overload, red
- [5] LVDT failure, red
- [6] Drive level to solenoid, yellow

Potentiometer

- [7] Offset

LED

- [8] Ramps enabled, yellow

Potentiometers

- [9] Acceleration ramp
- [10] Deceleration ramp

Monitor points ■

- [11] MP1: Conditioned command signal
- [12] Common ground (0V)
- [13] MP2: LVDT (spool) position ▲

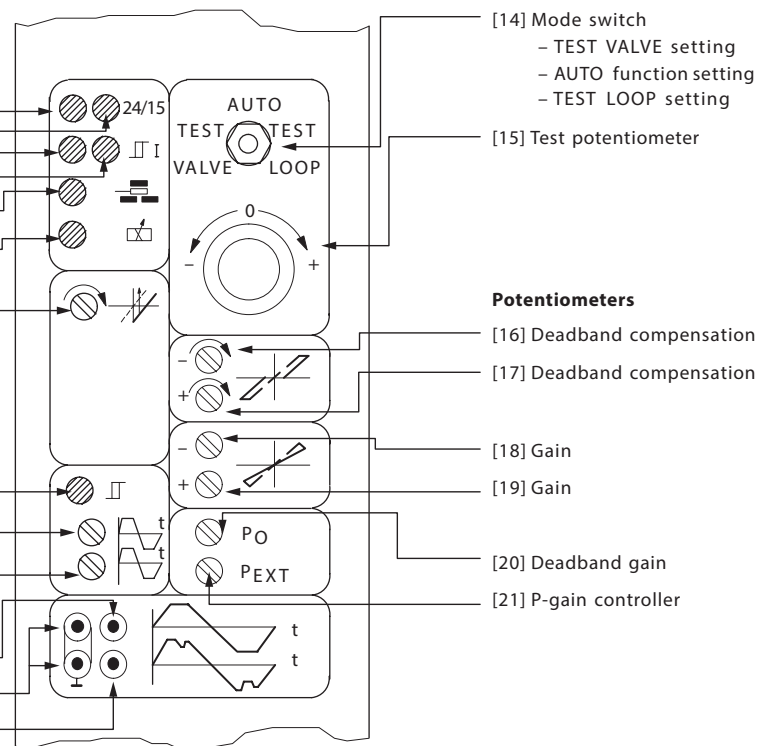

■ Ø2,0 mm (0.0787"dia.) sockets.

▲ Solenoid current for EEA-PAM-523/525-F models.

WARNING

Electromagnetic Compatibility (EMC)

It is necessary to ensure that the valve is wired up in accordance with the connection arrangements shown in this leaflet. For effective protection, the user's electrical cabinet, the valve subplate or manifold and the cable screens should be connected to efficient earth (ground) points. In all cases, both valve and cable should be kept as far away as possible from any source of electromagnetic radiation such as cables carrying heavy current, relays and certain kinds of portable radio transmitters, etc. Difficult environments could mean that extra screening may be necessary to avoid the interference.

Type F Power amplifiers with CNC adaptation modules

Model codes

Table 29.

Amplifier model	For valves
EEA-PAM-523-F-33	KDG4V-3 and KDG5V-5/7/8 } With type "H" coils only
EEA-PAM-525-F-33	
EEA-PAM-533-F-33	KFDG4V-3
EEA-PAM-535-F-33	KFDG4V-5
EEA-PAM-561-F-33	KFDG5V-5/7
EEA-PAM-568-F-33	KFDG5V-8
EEA-PAM-581-F-33	KHDG5V-5/7/8

Operating data

Table 30.

Power (input) supply	bdz32	See appropriate base amplifier, e.g. for EEA-PAM-535-F-33 see EEA-PAM-535-A-33
Control (output) supplies:	z22	+15V for LVDTs only
Reference voltages	z2 b2	+10V x 5mA -10V x 5mA
Analog inputs		
Command inputs		
Direct-voltage inputs	b6, b8, b10, z8	
Inverting-voltage input	z10	
Voltage range		±10V
Input impedance (voltage)		47 kΩ
Current input d28		
Current range		±20 mA
Input impedance (current)		100Ω
Input ramp		
Voltage range		±10V
Input impedance		10 kΩ
Velocity demand signal	d10, d16	
Voltage range		±10V
Input impedance		15 kΩ
Digital inputs:		
Drive enable (power available to solenoid)	z24	
Ramps enable	b24	
Enabled		17 to 40V
Disabled		0 to 3.5V
Load current		≤ 10 mA
Analog outputs:		
P-controller output		
Voltage ranged 12	±10V	
Load impedance		≥ 10 kΩ; short-circuit proof
Output ramp generator	d26	
Voltage range		±10V
Load impedance		≥ 10 kΩ; short-circuit proof

Type F Power amplifiers with CNC adaptation modules

Operating data

Table 30. continued

Alarm output:	z12	
Set alarm		Enable amplifier (on pin z24) when switching power on.
Signal		HIGH when alarm is activated. Output = Supply volts minus 2 volts. I = 50 mA max. LOW when solenoid overload has occurred. (Maintained until reset). Output = 0 to +/-2 volts. Output resistance = 50 ohms.
Reset after failure		Disable and re-enable on pin z24.
Potentiometers:		
Deadband compensation, separate control for each solenoid		0 to 50%
Gain, separate control for each solenoid		40 to 90%
P _D -Deadband gain		15 to 43 times
P _{EXT} -Gain controller:		
Without link		0,1 to 5 times
Link	d18 to d20	2 to 100 times
Integrated P-controller		The input circuit of the power amplifier card is used as a differential amplifier between the demand and feedback signals. The ramp signal generator can be used as profile generator. Caution: When using "TEST LOOP" the command signal has to be connected to d8, and d14 has to be connected to the command signal input of the input stage.
Hysteresis compensation:		
Link	d2 to d6	For KDG4V-* valves only
Monitor points:		
Conditioned command signal power amplifier	MP1	
LVDT (spool) position ▲	MP2	
Voltage range		± 10V
Monitor point impedance		10 kΩ
Ambient conditions:		
Storage temperature range		-25 to +85C (-13 to +185F)
Operating temperature range		0 to 50C (32 to 122F)
Mass		0.4 kg (0.88 lb) approx.
Installation wiring requirements for Vickers electronic products		2468
Cardholder	F48	02-104808
Integrated test modes		See Test Mode details below

▲ Solenoid current for EEA-PAM-523/525-F models.

Type F Power amplifiers with CNC adaptation modules

Circuit and Connections

EEA-PAM-5**-F-33

Note: Read circuit in conjunction with that for relevant base amplifier
EEA-PAM-5**-A

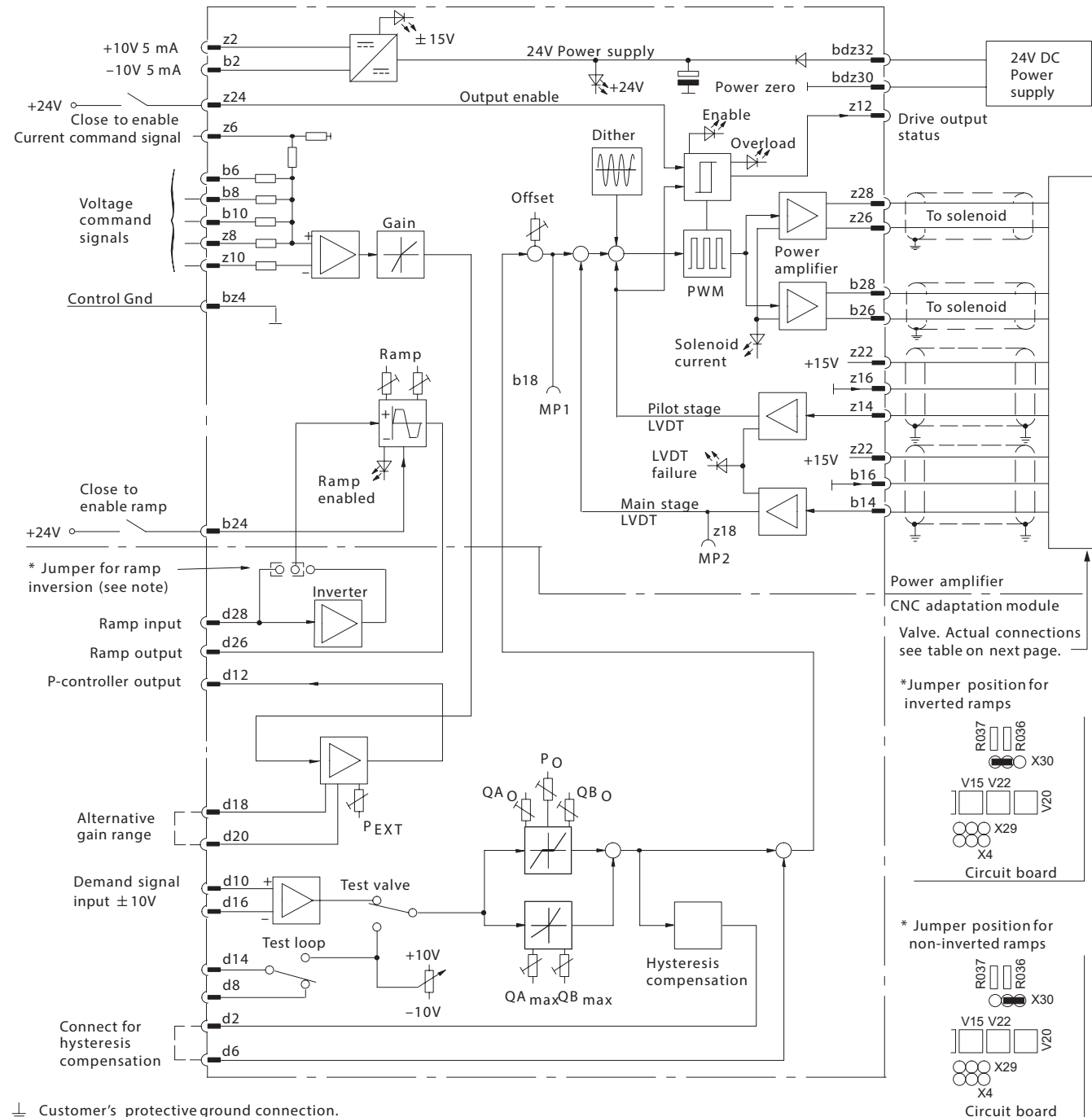

Type F Power amplifiers with CNC adaptation modules

Solenoid and LVDT connections for proportional valves

Table 31.

Amplifier type	Solenoid with LVDT and/or for flow P to B	Solenoid without LVDT, or on pilot valve	Pilot-stage LVDT, (black plug):				Main-stage LVDT, (gray plug):			
			Pin 1	Pin 2	Pin 3	Pin 4	Pin 1	Pin 2	Pin 3	Pin 4
EEA-PAM-523-F-33	b26/b28	z26/z28	-	-	-	Not connected	-	-	-	Not connected
EEA-PAM-525-F-33	b26/b28	z26/z28	-	-	-	Not connected	-	-	-	Not connected
EEA-PAM-533-F-33	b26/b28	z26/z28	-	-	-	Not connected	b14	z22	b16	Not connected
EEA-PAM-535-F-33	b26/b28	z26/z28	-	-	-	Not connected	b14	z22	b16	Not connected
EEA-PAM-561-F-33	-	z26/z28	-	-	-	Not connected	b14	z22	b16	Not connected
EEA-PAM-568-F-33	-	z26/z28	-	-	-	Not connected	b14	z22	b16	Not connected
EEA-PAM-581-F-33	-	z26/z28	z14	z22	z16	Not connected	b14	z22	b16	Not connected

Installation Dimensions in mm (inches)

Plug-in Unit of 3U Height, to IEC 297

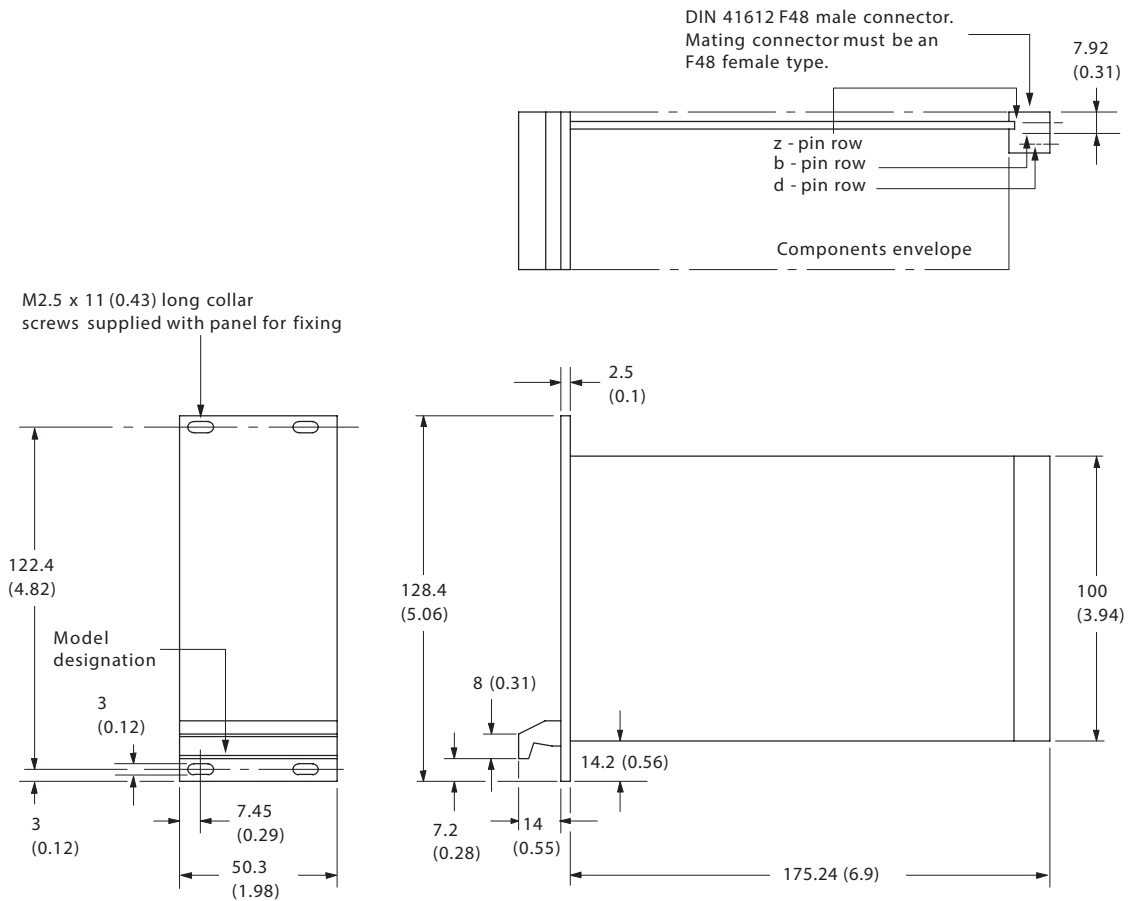

Type F Power amplifiers with CNC adaptation modules

Operation of the integrated test mode

The basic operation of the hydraulic actuator can be tested by using the 3-position mode switch mounted on the front panel. To select different modes the toggle switch must be lifted slightly before moving to a new position.

CAUTION

Before setting the mode switch to either "Test valve" or "Test loop" make sure the test potentiometer is set to "0". Otherwise sudden movements of the actuator may occur.

The mode switch has three positions:

Auto

The controller operates in closed-loop mode, using the external command signal. The test potentiometer is disconnected.

Test valve

An open-loop command signal for the valve comes directly from the potentiometer. The external input signal is disconnected. The hydraulic part of the system may be tested in this configuration.

Test loop

The test potentiometer can be used to drive the separate P-controller, if "Test loop" (closed spool) is selected. The external input signal is disconnected. See wiring example. "Test loop" is usable only if the separate P-controller is used.

CAUTION

When using "TEST LOOP" the command signal has to be connected to d8, and d14 to be connected to the command signal input of the input stage.

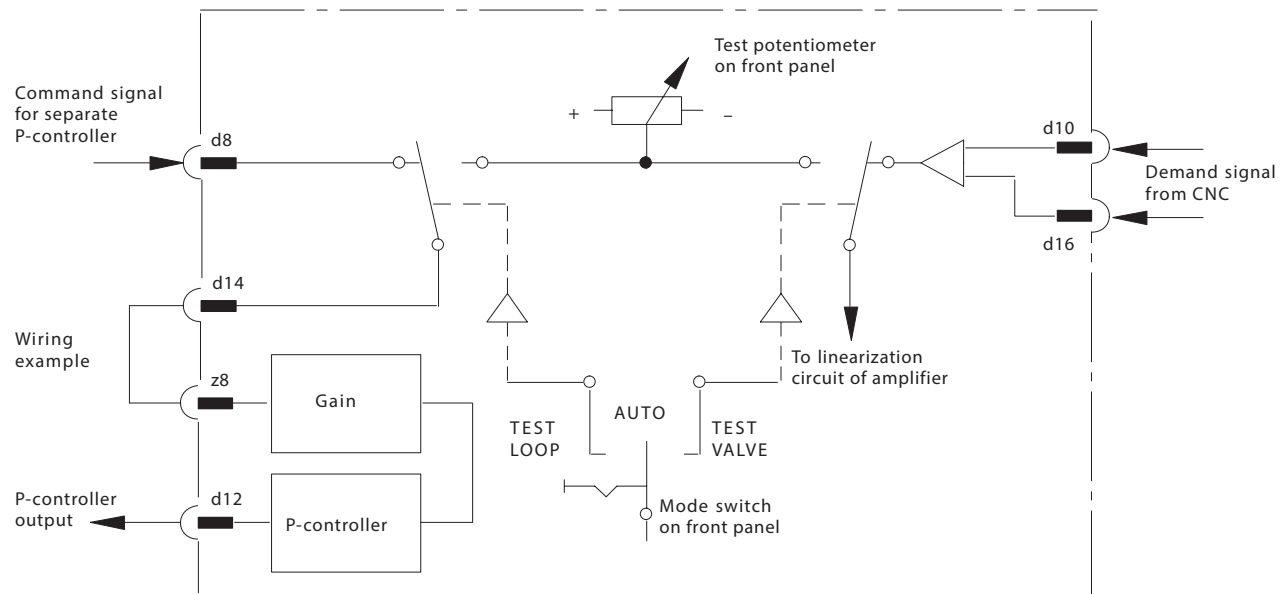

Type F Power amplifiers with CNC adaptation modules

Application example

Positioning module with CNC axis controller

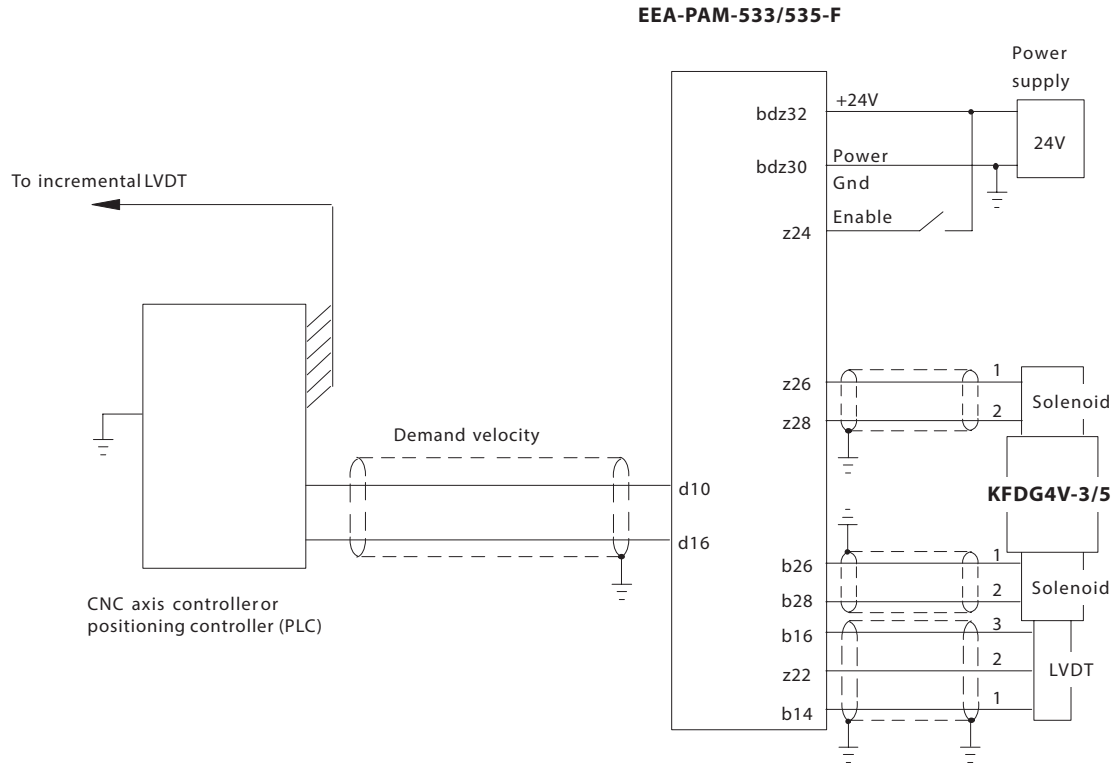

Type F Power amplifiers with CNC adaptation modules

Dedicated installation recommendation for Type F card

The operation of this amplifier has been factory-checked before despatch as meeting the specification shown in this catalog.

1. Wiring sizes

Use screened cable $\geq 0.5 \text{ mm}^2$ (20 AWG) per wire for signal and LVDT wiring.

For wiring runs between amplifier and solenoid up to 25 metres (82 ft), use wire of $\geq 1 \text{ mm}^2$ (18 AWG) cross-section





2. Installation requirements according to European EMC regulations

The wiring to the machine controller should be screened. The screen should be connected to an efficient ground point at the amplifier end.

3. Front panel indicator lights (LEDs)

Amplifiers may have some, or all, of the following LEDs, depending on amplifier type:

Table 32.

Panel symbol	Function indicated	Color	Normal working state
24V	Power supply ON	Green	ON
15V	Internal supply ON	Green	ON
	Output enabled	Yellow	ON
	Overload detection	Red	OFF
	LVDT failure	Red	OFF
	Ramps enabled	Yellow	ON
	Current to solenoid (Light intensity varies with solenoid current)	Yellow	ON

4. Front panel controls

a. Gain

The two gain potentiometers are factory set to maximum, and operate separately on positive and negative demand signals

b. Deadband compensation:

The two potentiometers are factory set at 10% (20% for type 523 and 533) of valve maximum spool stroke. The setting may be optimized for your application as follows: Apply a small command signal (e.g. 250 mV) and check for hydraulic response from the valve. (For 2-stage valves the correct pilot pressure must be available to obtain response from the main-stage spool.) If this does not occur then adjust the applicable potentiometer clockwise until it does. Alternatively, to reduce valve hydraulic response turn the potentiometer counter-clockwise.

c. Ramps

The ramp generation is used to ramp the command signal. The factory setting of ramp potentiometers are minimum ramp time. Turning the controls clockwise increases ramp time, turning counter-clockwise decreases ramp time. The ramp signal may be inverted by changing a jumper on the circuit board.

d. Offset

This potentiometer is used to set the value to null

e. Deadband gain

Potentiometer P_0 is used to set the electrical gain within the deadband region. The gain factor is very high (30 to 90). This increased gain in the deadband has the effect of linearizing the valve characteristic. This potentiometer is normally set to maximum gain. In the event of stability problems in the deadband region, the gain factor must be reduced.

f. P-Gain controller

The P_{EXT} potentiometer adjusts the gain of the P position controller.

5. Fault diagnosis

If the amplifier fails to work the following checks should be made:

- Check that all wiring is correct to the machine designer's instructions.
- Check that there is a 24V supply and that the 24V LED is ON.
- Check that the 15V internal voltage LED is ON (if 24V LED is ON and this 15V LED is OFF then the amplifier should be replaced.)
- Check that the amplifier is enabled and the LED is ON.
- Check that the LVDT failure LED is OFF. (If ON check the LVDT wiring and connections.)

To check correct function of the amplifier for a feedback valve, disconnect all valve connections and link z22 (+15V) with a 1.2 k Ω resistor to b14. (To check the double feedback amplifiers EEA-PAM -581, make an additional link between z22 (+15V) and z14 with a 1.2 k Ω resistor.)

After installation of resistor link(s), the LVDT failure LED should be OFF. If not, replace the amplifier

Caution: a link without resistor damages the amplifier

- Check that the overload LED is OFF. (If ON, check the wiring to the solenoids and the solenoid resistance by an ohmmeter. Compare the measured value with the catalog data.)
- Check that an appropriate valve driving signal is available (monitor point MP1 at the front panel).
 - $\pm 10V$ at monitor point represents $\pm 100\%$ output of the valve.
- The solenoid current (non-feedback valves) or the LVDT signal (feedback valves) can be measured at the front panel monitor point MP2.
 - Solenoid current can be measured as a voltage signal (1 volt per amp)
 - $\pm 10V$ LVDT signal at monitor point represents $\pm 100\%$ stroke.

Note: Due to the effect of spool overlap, the working range is typically 3 to 9 volts for the flows from zero to maximum.

Type F Power amplifiers with CNC adaptation modules

6. Valve connection table

This table shows how the different valves have to be connected to the associated amplifier.

Table 33.

Value type	Amplifier type	Solenoid with LV DT or hydraulic A	Solenoid without LV DT or hydraulic B	Pilot stage LV DT				Main stage LVDT			
				Pin 1	2	3	4	Pin 1	2	3	4
K*G4V-3 and KDG5V-5/7/8	EEA-PAM-523-F-33	b26/b28	z26/z28	-	-	-	-	-	-	-	-
K*G4V-5	EEA-PAM-525-F-33	b26/b28	z26/z28	-	-	-	-	-	-	-	-
KF*G4V-3	EEA-PAM-533-F-33	b26/b28	z26/z28	-	-	-	Not connected	b14	z22	b16	Not connected
KF*G4V-5	EEA-PAM-535-F-33	b26/b28	z26/z28	-	-	-		b14	z22	b16	
KFDG5V-5/7	EEA-PAM-561-F-33	-	z26/z28	-	-	-	-	b14	z22	b16	-
KFDG5V-8	EEA-PAM-568-F-33	-	z26/z28	-	-	-	-	b14	z22	b16	-
KHDG5V-5/7/8	EEA-PAM-581-F-33	-	z26/z28	z14	z22	z16	-	b14	z22	b16	-

Note: If valves are fitted with the “B” type LVDT, the screen will be grounded at the valve end by the shell of the connector.

EURO PAM card offerings

Table 34.

Model No	33- Series Assembly Number	32-Series Assembly Number
EEA-EDC-436-A1-33	105EC00004	02-326120
EEA-EDC-436-A2-33	105EC00005	02-326132
EEA-EDC-436-A3-33	105EC00006	02-326133
EEA-EDC-436-D1-33	105EC00007	02-326129
EEA-EDC-436-D3-33	105EC00008	02-326131
EEA-PAM-511-A-33	105EC00009	02-326000
EEA-PAM-511-A-33-EN8 ▲	105EC00010	02-326095
EEA-PAM-511-B-33	105EC00011	02-326019
EEA-PAM-511-D-33	105EC00012	02-326036
EEA-PAM-513-A-33	105EC00013	02-326016
EEA-PAM-513-A-33-EN49 ▲	105EC00014	3041111
EEA-PAM-513-A-33-EN53 ▲	105EC00015	6025852-001
EEA-PAM-513-B-33	105EC00016	02-326020
EEA-PAM-513-D-33	105EC00017	02-326037
EEA-PAM-523-A-33	105EC00018	02-326001
EEA-PAM-523-A-33-EN18 ▲	105EC00019	02-326116
EEA-PAM-523-B-33	105EC00020	02-326021
EEA-PAM-523-C-33	105EC00021	02-326029
EEA-PAM-523-D-33	105EC00022	02-326038
EEA-PAM-523-E-33	105EC00023	02-326048
EEA-PAM-523-F-33	105EC00024	02-326057
EEA-PAM-525-A-33	105EC00025	02-326017
EEA-PAM-525-B-33	105EC00026	02-326022
EEA-PAM-525-C-33	105EC00027	02-326030
EEA-PAM-525-D-33	105EC00028	02-326039
EEA-PAM-525-E-33	105EC00029	02-326049
EEA-PAM-525-F-33	105EC00030	02-326058
EEA-PAM-533-A-33	105EC00031	02-326002
EEA-PAM-533-B-33	105EC00032	02-326023
EEA-PAM-533-C-33	105EC00033	02-326031
EEA-PAM-533-D-33	105EC00034	02-326040
EEA-PAM-533-E-33	105EC00035	02-326050
EEA-PAM-533-F-33	105EC00036	02-326059
EEA-PAM-535-A2-33	105EC00037	02-326104
EEA-PAM-535-A-33	105EC00038	02-326003
EEA-PAM-535-A-33-EN3 ▲	105EC00039	02-326172
EEA-PAM-535-B-33	105EC00040	02-326024
EEA-PAM-535-B-33-EN9 ▲	105EC00041	02-326101
EEA-PAM-535-C-33	105EC00042	02-326032
EEA-PAM-535-D2-33	105EC00043	02-326105
EEA-PAM-535-D-33	105EC00044	02-326041
EEA-PAM-535-D-33-EN57 ▲	105EC00045	6038729-001
EEA-PAM-535-D-33-EN53 ▲	105EC00046	3041191
EEA-PAM-535-E-33	105EC00047	02-326051
EEA-PAM-535-F-33	105EC00048	02-326060
EEA-PAM-541-A-33	105EC00049	02-326008
EEA-PAM-541-D-33	105EC00050	02-326042
EEA-PAM-541-E-33	105EC00051	02-326052
EEA-PAM-553-A-33	105EC00052	02-326004

Table 34. Continued

Model No	33- Series Assembly Number	32-Series Assembly Number
EEA-PAM-553-A-33-EN14 ▲	105EC00053	02-326109
EEA-PAM-553-D-33	105EC00054	02-326043
EEA-PAM-553-D-33-EN27 ▲	105EC00055	02-326166
EEA-PAM-553-E-33	105EC00056	02-326053
EEA-PAM-561-A-33	105EC00057	02-326005
EEA-PAM-561-B-33	105EC00058	02-326025
EEA-PAM-561-C-33	105EC00059	02-326033
EEA-PAM-561-D-33	105EC00060	02-326044
EEA-PAM-561-E-33	105EC00061	02-326054
EEA-PAM-561-F-33	105EC00062	02-326061
EEA-PAM-568-A-33	105EC00063	02-326006
EEA-PAM-568-B-33	105EC00064	02-326026
EEA-PAM-568-C-33	105EC00065	02-326034
EEA-PAM-568-D-33	105EC00066	02-326045
EEA-PAM-568-E-33	105EC00067	02-326055
EEA-PAM-568-F-33	105EC00068	02-326062
EEA-PAM-571-A-33	105EC00069	02-326007
EEA-PAM-571-A-33-EN26 ▲	105EC00070	02-326165
EEA-PAM-571-A-33-EN55 ▲	105EC00071	3041197
EEA-PAM-571-B-33	105EC00072	02-326027
EEA-PAM-571-D-33	105EC00073	02-326046
EEA-PAM-581-A-33	105EC00074	02-326018
EEA-PAM-581-B-33	105EC00075	02-326028
EEA-PAM-581-C-33	105EC00076	02-326035
EEA-PAM-581-D-33	105EC00077	02-326047
EEA-PAM-581-D-33-EN3 ▲	105EC00078	02-326148
EEA-PAM-581-D-33-EN53 ▲	105EC00079	3041192
EEA-PAM-581-E-33	105EC00080	02-326056
EEA-PAM-581-F-33	105EC00081	02-326063
EEA-PAM-535-D-33 EN3 ▲	105EC00082	02-104849
EEA-EDC-436-D2-33	105EC00083	02-326130

Special versions (▲)

Table 35.

EN version	Details
EN 3	SPECIAL VERSION OF EEA-PAM-535-A-33,EEA- PAM-535-D-33, EEA-PAM-581-D-33 WITH COMPATABILITY TO SWEDISH EMC STANDARDS
EN 8	SPECIAL VERSION OF EEA-PAM-511-A-33 WITH 30 SECOND RAMP TIME
EN9	SPECIAL VERSION OF EEA-PAM-535-B-33 WITH MODIFIEDRAMP TIME
EN14	SPECIAL VERSION OF EEA-PAM-553-A-33 WITH MODIFIEDDITHER FOR BETTER SMALL STEP RESPONSE
EN18	SPECIAL VERSION OF EEA-PAM-523-A-33 WITH DIFFERENT DITHER SETTING FOR KTG PLUS VALVISTOR-SLIP-IN LOWER HYSTERESIS
EN26	SPECIAL VERSION OF EEA-PAM- 571- A-33WITH HIGHER DITHER
EN27	SPECIAL VERSION OF EEA-PAM-553-D-33 FOR ABB SWEDEN
EN49	SPECIAL VERSION OF EEA-PAM-513-A-33 WITH 24 HOURRUN IN TEST CONFORMAL COATED PCB
EN53	SPECIAL VERSION OF EEA-PAM-535-D-33, EEA-PAM-581-D-33,EEA-PAM-513-A-33 WITH ONLY CURRENT COMMAND INPUT OF 4 MA..20 MA
EN55	SPECIAL VERSION OF EEA-PAM-571-A-33 WITH 10 SECONDS RAMP TIME
EN57	SPECIAL VERSION OF EEA-PAM-535-D-33 WITH ONLY CURRENT COMMAND INPUT OF 4 MA..20 MA

Products we offer:

- Cartridge valves
- DCV directional control valves
- Electric converters
- Electric machines
- Electric motors
- Gear motors
- Gear pumps
- Hydraulic integrated circuits (HICs)
- Hydrostatic motors
- Hydrostatic pumps
- Orbital motors
- PLUS+1[®] controllers
- PLUS+1[®] displays
- PLUS+1[®] joysticks and pedals
- PLUS+1[®] operator interfaces
- PLUS+1[®] sensors
- PLUS+1[®] software
- PLUS+1[®] software services, support and training
- Position controls and sensors
- PVG proportional valves
- Steering components and systems
- Telematics

Danfoss Power Solutions is a global manufacturer and supplier of high-quality hydraulic and electric components. We specialize in providing state-of-the-art technology and solutions that excel in the harsh operating conditions of the mobile off-highway market as well as the marine sector. Building on our extensive applications expertise, we work closely with you to ensure exceptional performance for a broad range of applications. We help you and other customers around the world speed up system development, reduce costs and bring vehicles and vessels to market faster.

Danfoss Power Solutions – your strongest partner in mobile hydraulics and mobile electrification.

Go to www.danfoss.com for further product information.

We offer you expert worldwide support for ensuring the best possible solutions for outstanding performance. And with an extensive network of Global Service Partners, we also provide you with comprehensive global service for all of our components.

Local address:

Hydro-Gear

www.hydro-gear.com

Daikin-Sauer-Danfoss

www.daikin-sauer-danfoss.com

Danfoss Power Solutions (US) Company
2800 East 13th Street
Ames, IA 50010, USA
Phone: +1 515 239 6000

Danfoss Power Solutions GmbH & Co. OHG
Krokamp 35
D-24539 Neumünster, Germany
Phone: +49 4321 871 0

Danfoss Power Solutions ApS
Nordborgvej 81
DK-6430 Nordborg, Denmark
Phone: +45 7488 2222

Danfoss Power Solutions Trading (Shanghai) Co., Ltd.
Building #22, No. 1000 Jin Hai Rd
Jin Qiao, Pudong New District
Shanghai, China 201206
Phone: +86 21 2080 6201