

ICE120 - Overcenter valve

Pilot assisted relief with check
120 L/min (32 USgpm) • 270 bar (4000 psi)

www: www.salushydraulics.pl
e-mail: pl@salushydraulics.pl
shop/sklep: www.salushydraulics.pl/sklep/

1CE120-F-35S3

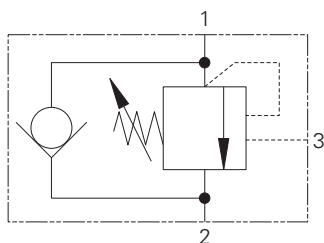

Operation

The check section allows free flow into the actuator then holds and locks the load against movement. The pilot assisted relief valve section will give controlled movement when pilot pressure is applied. The relief section is normally set to open at a pressure at least 1.3 times the maximum load induced pressure but the

pressure required to open the valve and allow movement depends on the pilot ratio of the valve. For optimization of load control and energy usage, a choice of pilot ratios is available

The pressure required to open the valve and start actuator movement can be calculated as follows:

$$\text{Pilot Pressure} = \frac{(\text{Relief Setting}) - (\text{Load Pressure})}{\text{Pilot Ratio}}$$

Features

Cartridge is economical and fits simple cavity. Allows quick, easy field service - reduces down time. Interchangeable with pilot check valve of a similar size.

Pilot ratio

3.5:1 (standard) Best suited for applications where load varies and machine structure can induce instability.

8:1 Best suited for applications where the load remains relatively constant.

Sectional view

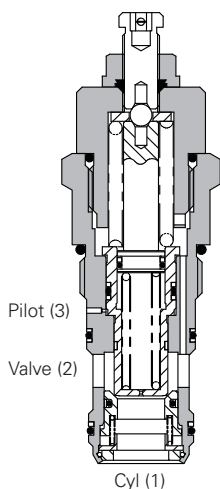

Performance data

Ratings and specifications

Figures based on: Oil Temp = 40°C Viscosity = 32 cSt (150 SUS)

Rated flow	120 L/min (32 USgpm)
Max relief setting	350 bar (5000 psi)
Max load induced pressure	270 bar (4000 psi)
Cartridge material	Working parts hardened and ground steel. External surfaces zinc plated.
Standard housing material	Aluminum (up to 210 bar). Add suffix "377" for steel option.
Mounting position	Unrestricted
Cavity number	A877 (See Section M)
Torque cartridge into cavity	100 Nm (74 lbs ft)
Weight	1CE120 0.59 kg (1.30 lbs) 1CE150 1.46 kg (3.20 lbs) 1CEE150 2.58 kg (5.70 lbs)
Seal kit number	SK417 (Nitrile) SK417V (Viton®)
Recommended filtration level	BS5540/4 Class 18/13 (25 micron nominal)
Operating temperature	-30°C to +90°C (-22° to +194°F)
Leakage	0.3 milliliters/min nominal (5 dpm)
Nominal viscosity range	5 to 500 cSt

Viton is a registered trademark of E.I. DuPont.

Pressure drop

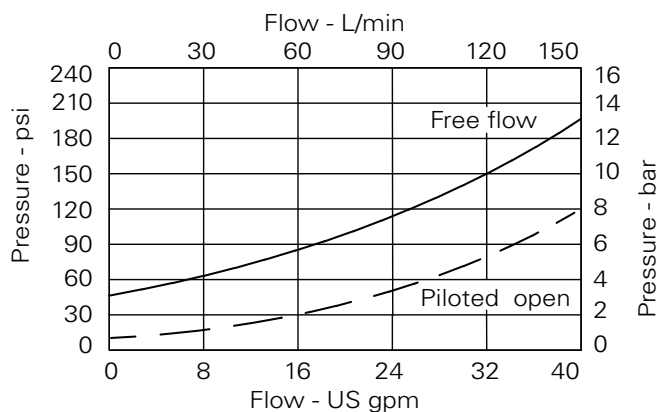

Description

Overcenter valves give static and dynamic control of loads by regulating the flow into and out of hydraulic actuators. When installed close to or within an actuator, the overcenter valve will stop runaway in the event of hose burst and if open center directional control valves are used, will allow thermal expansion relief of the hydraulic fluid.

The overcenter cartridge is ideal for mounting directly into a cavity machined in the body of the cylinder, motor or rotary actuator. The cartridge can also be mounted directly to the ports via a specifically machined body as part of a Hydraulic Integrated Circuit or single unit, or contained within one of our standard line bodies.

Single overcenter valves are normally used when the load is unidirectional, for example an aerial platform or crane and dual overcenter valves are used for controlling loads in both directions for motor applications or for cylinders going over center.

Where measurements are critical request certified drawings. We reserve the right to change specifications without notice.

ICE120 - Overcenter valve

Pilot assisted relief with check
120 L/min (32 USgpm) • 270 bar (4000 psi)

Model code

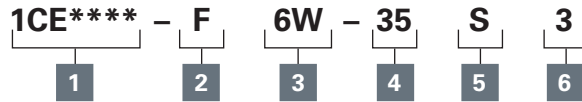

1 Function

1CE120 - Cartridge Only
1CE150 - Cartridge and Body
1CEE150 - Cartridges and Dual Body

2 Adjustment means

F - Screw Adjustment

3 Port sizes

Code	Port size	Housing number			
		Aluminium single	Steel single	Aluminium dual	Steel dual
6W	3/4" BSP Valve & Cyl Port. 1/4" BSP Pilot Port	B6898	B5544	C2543	C1200
12T	3/4" SAE Valve & Cyl Port. 1/4" SAE Pilot Port	B8200		C10629	C16434
16T	1" SAE Valve & Cyl Port. 1/4" SAE Pilot Port	B10708	B11814		

4 Pressure range @ 4.8 l/min

Note: Code based on pressure in bar.

35 - 70-350 bar.
Std setting 210 bar

Std setting made at 4.8 L/min

5 Seals

S - Nitrile (For use with most industrial hydraulic oils)

SV - Viton (For high temperature and most special fluid applications)

6 Pilot Ratio

3 - 3.5:1

8 - 8:1

Dimensions

mm (inch)

Cartridge only

Basic Code
ICE120

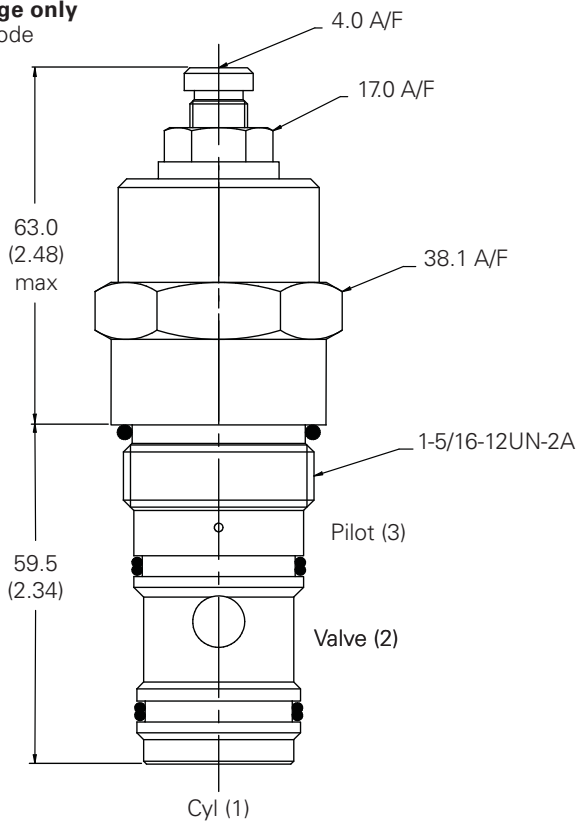

Note: Tightening torque of "F" adjuster locknut - 20 to 25 Nm.

Note: For applications above 210 bar - please consult our technical department or use the steel body option.

Single valve

3/4", 1" Ports
Basic Code
1CE150

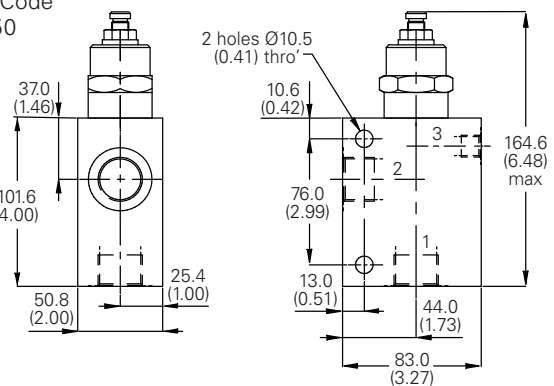

Dual valve

3/4"
Basic Code 1CEE150
Internally Cross Piloted

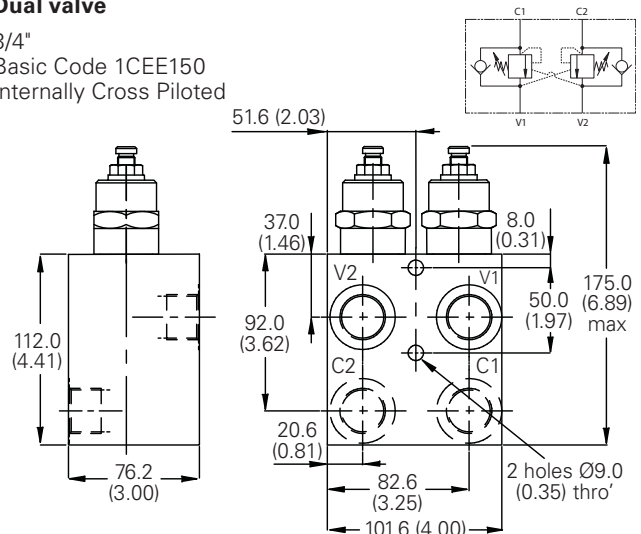

Where measurements are critical request certified drawings. We reserve the right to change specifications without notice.