

SystemStak™ Flow Control Valves



www: www.salushydraulics.pl
 e-mail: pl@salushydraulics.pl
 shop/sklep: www.salushydraulics.pl/sklep/

DGMFN

General Description

These valves are adjustable, non-compensated flow restrictors. An integral check valve around the regulating orifice allows free flow in one direction and metered flow in the other.

Control is available in "A" only, "B" only, and "A" and "B" ports as an "X" type (meter-in) or "Y" type (meter-out).

The "P" port is available only in the "X" type (meter-in) and does not contain a reverse flow check.

The valve flow setting is adjustable by means of either a hex key adjusting screw and locknut, a hand-adjust knob, or a micrometer knob with keylock.

A normal or fine metering capability is available. See the pressure drop curves on page 26 for detailed performance difference.

Model Code

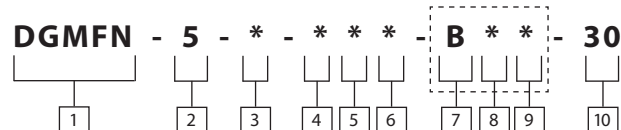

1 Valve function

Manifold or subplate mounted flow control valve.

2 Interface

5 – ISO 4401-AC-05-4-A, CETOP 5 Size
5 RP35H ANSI/NFPA D05

3 Direction of flow

X – Meter-in
Y – Meter-out

4 Port operated upon

A – Cylinder port "A" (single or dual type)
B – Cylinder port "B" (single type only)
P – Pressure port (single type only)

5 Adjustment range

1 – Fine control
2 – Normal control

6 Adjustment device

H – Knob adjuster
K – Micrometer knob with keylock
W – Screw with locknut

7 Port operated upon: second function

(Omit for single flow control models.)
B – B cylinder port (Dual type)

8 Adjustment range: second function

(Omit for single flow control models.)
1 – Fine control
2 – Normal control

9 Adjustment device: second function

(Omit for single flow control models.)
H – Knob adjuster
K – Micrometer knob with keylock
W – Screw with locknut

10 Design number - 30 series

Subject to change. Installation dimensions unaltered for design numbers 30 to 39 inclusive.

DGMFN-5- X-P**-30

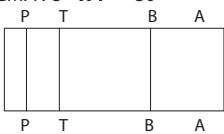

DGMFN-5- X-A**-B**-30

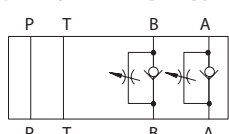

DGMFN-5- X-A**-30

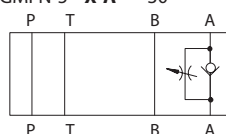

DGMFN-5- X-B**-30

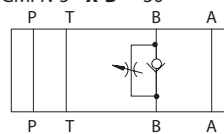

DGMFN-5- Y-A**-B**-30

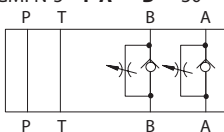

DGMFN-5- Y-A**-30



DGMFN-5- Y-B**-30

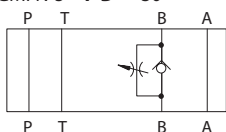

Basic Characteristics

Maximum flow	120 l/min (32 USgpm)
Maximum operating pressure	315 bar (4500 psi)
Operating temperature	20° to 50°C (70° to 120°F)
Weights	3,1 kg (7 lbs)

Performance Data

Minimum Controlled Flow/No-Flow Leakage

Internal leakage will vary from valve to valve and with the pressure differential across the check. Approximate levels are:

Pressure Drop bar (psi)	Leakage* cc/min (in3/min)
50 (725)	160 (9.5)
100 (1450)	320 (19)
200 (2900)	640 (38)
315 (4500)	990 (60)

* Equals minimum controllable flow rate at the pressures stated.

Pressure Drop

The curves below show the pressure drop through individual flow passages. Curves labeled "metered flow/pressure drop" refer to the pressure drop through only the passage containing the flow control regulating orifice. Total valve insertion loss is a value derived from graph 1 or 2 plus the appropriate values of lines 1, 2 and 3 from graph 3.

Graph 1

Metered flow pressure drop.
Normal adjustment – "2"
models (see model code,
page 24).

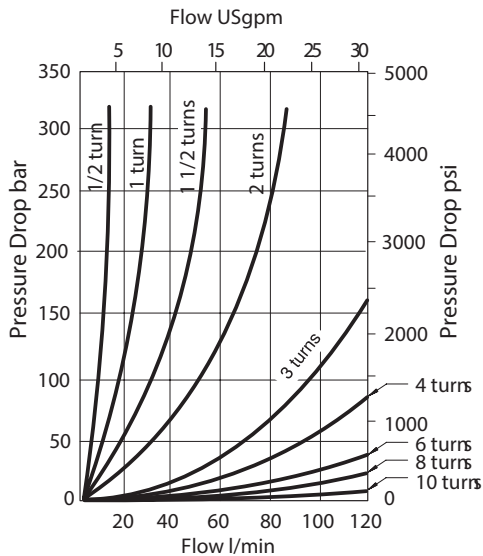

Graph 2

Metered flow pressure drop.
Fine adjustment – "1" models
(see model code, page 24).

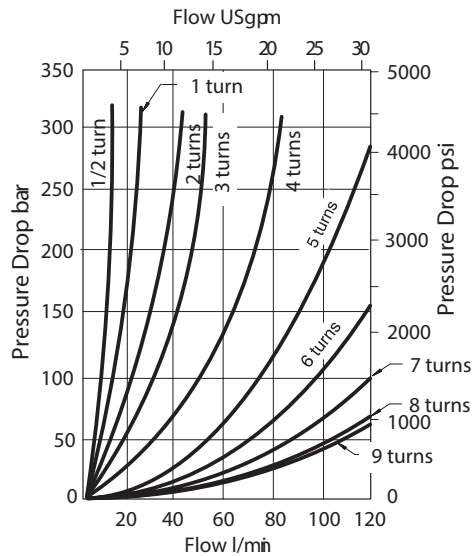

Graph 3

Free flow pressure drop across
check valve.

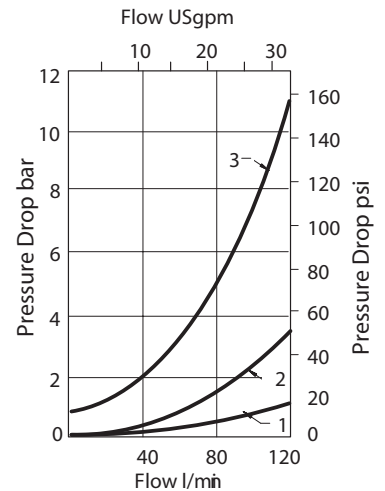

Graph 3

- 1 – "P" port of all models except DGMFN-5-X-P**-30
"B" and "T" ports of DGMFN-5-X-P**-30
- 2 – "T" port of all models except DGMFN-5-X-P**-30
"A" ports of DGMFN-5-X-P**-30
- 3 – Pressure drop across reverse free flow check valve

Note: "Turn" or "Turns" on curves in graphs 1 and 2, above, refer to turn of adjustment device from fully closed position.

Installation Dimensions



DGMFN-5-X-P & DGMFN-5-Y-A

Single Flow Controls

mm (inches)



4 mounting holes \varnothing 6,9 (0.27) through \varnothing 9,50 (0.37) counterbore 36,5 (1.44) deep for bolt extenders (order separately) BKE-6M-50M (M6 metric) or BKE-4-50M (.2500-20 UNC). Torque: 11,3-14,7 Nm (100-130 lb. in.)

Model	A	B
DGMFN-5-X-P	60,4 (2.38)	28,4 (1.12)
DGMFN-5-Y-A	52,7 (2.07)	33,2 (1.31)

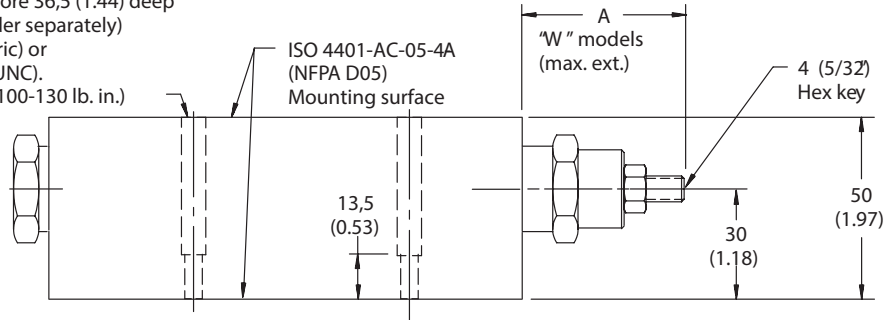

No hex plug on DGMFN-5-X-P models

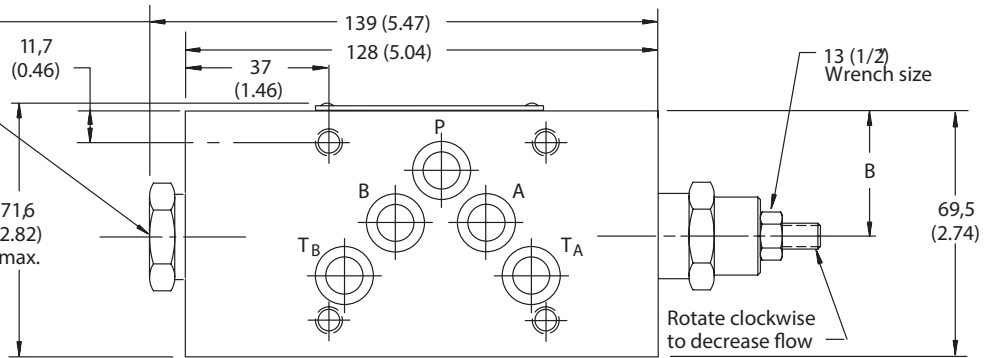

See page 37 for optional adjustment devices.

See page 38 for interface dimensions.

DGMFN-5-X-A

Single Flow Control

mm (inches)

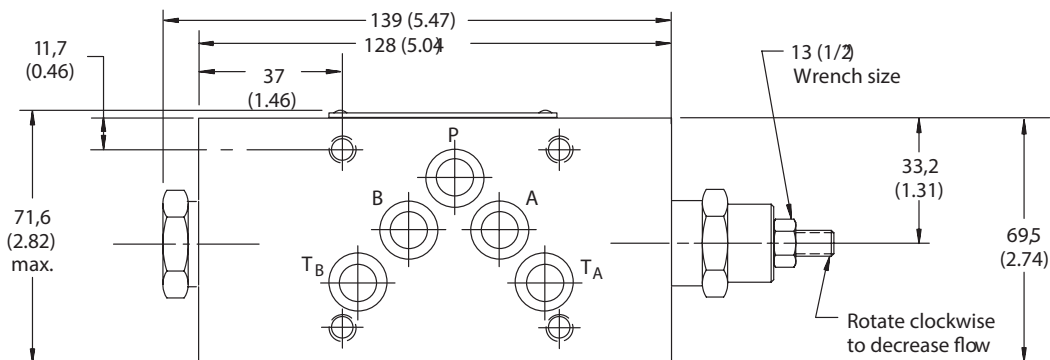
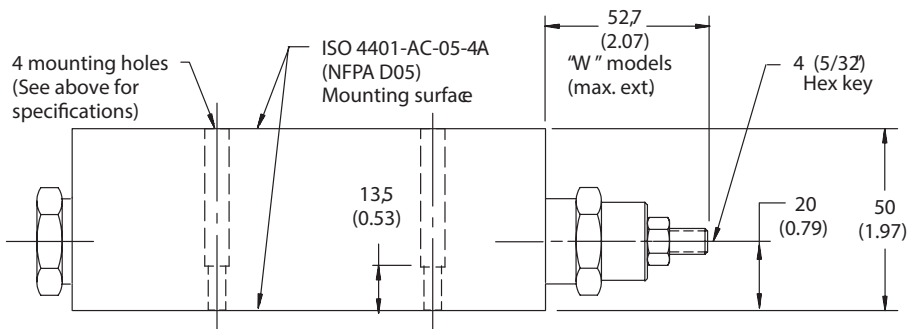

Installation Dimensions



DGMFN-5-X-B Single Flow Control mm (inches)

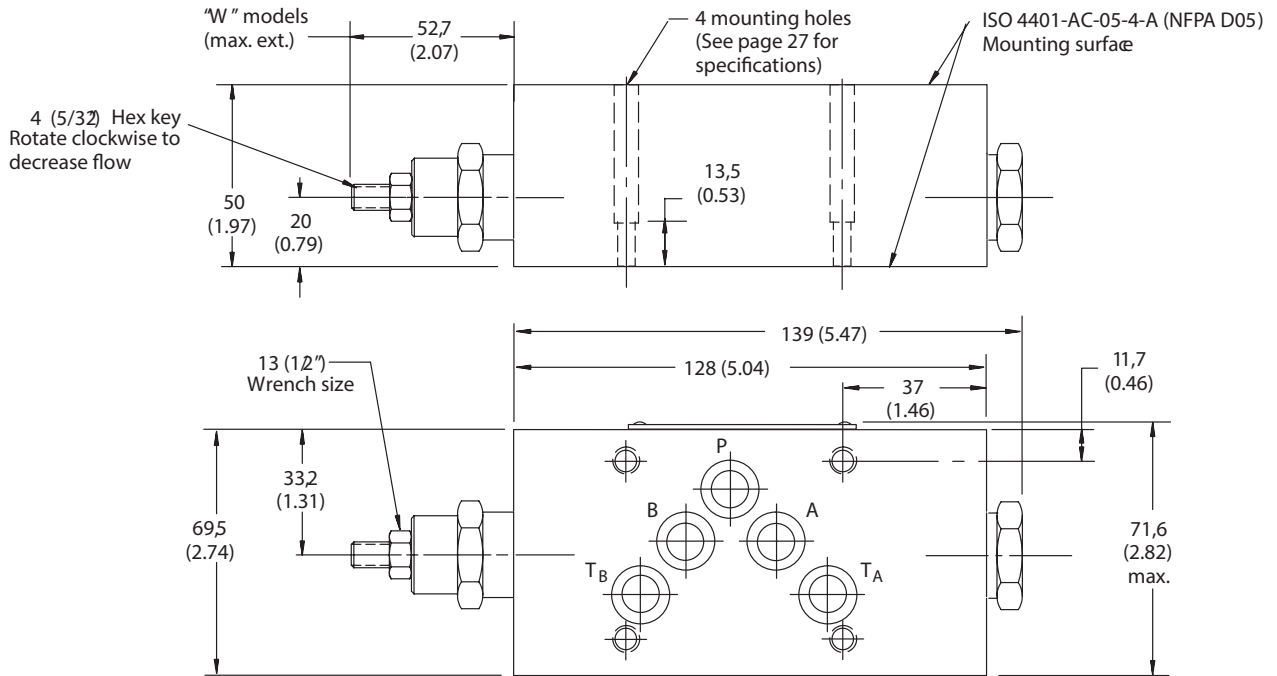

See page 37 for optional adjustment devices.
See page 38 for interface dimensions.

DGMFN-5-Y-B Single Flow Control

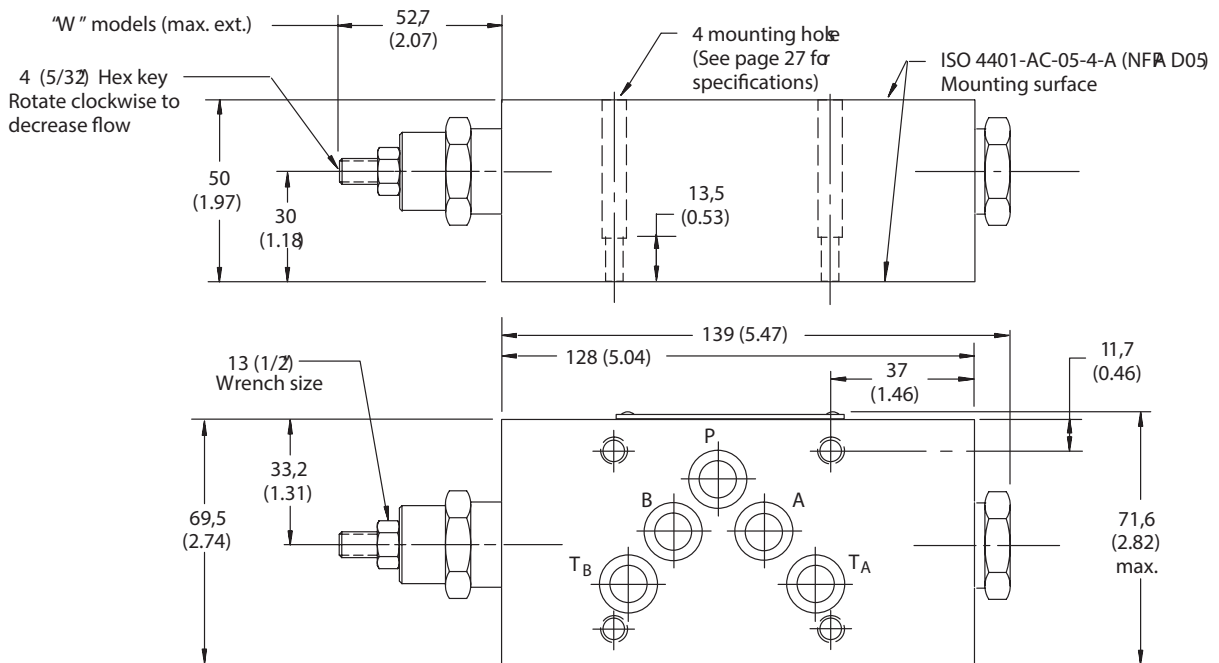

Installation Dimensions



DGMFN-5-Y Dual Flow Control

mm (inches)

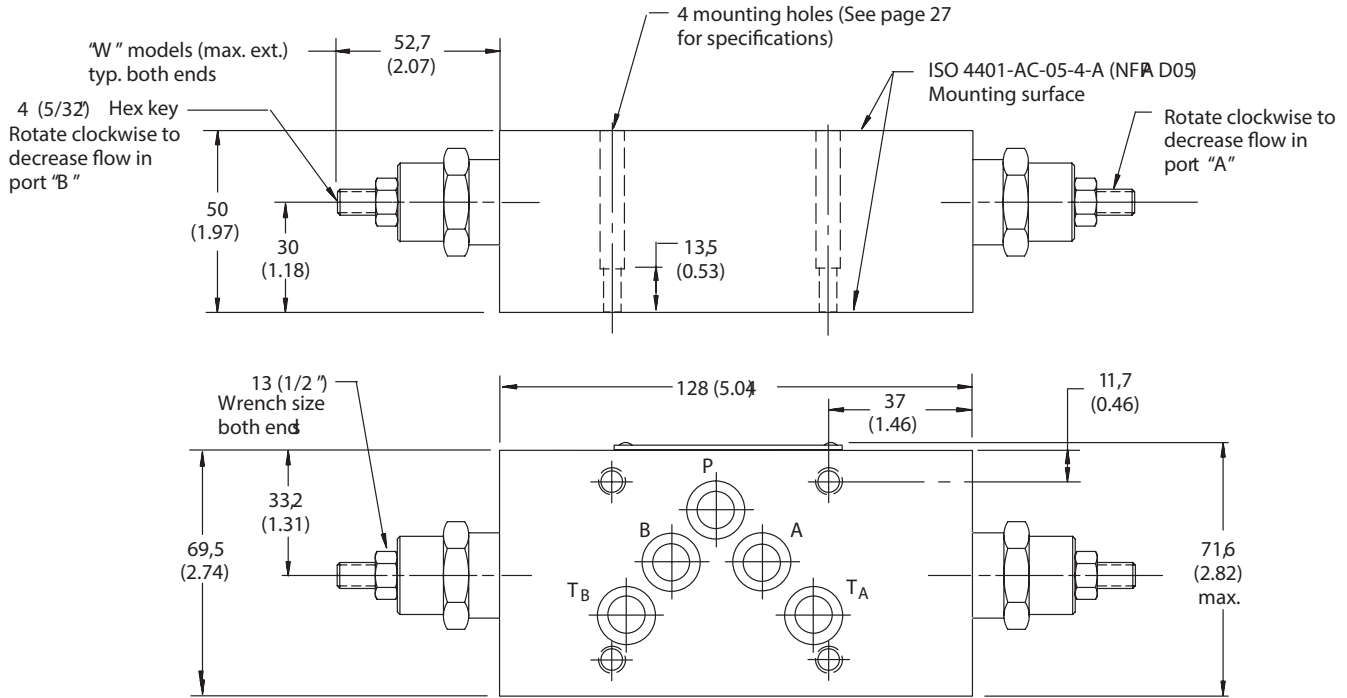

See page 37 for optional adjustment devices.
See page 38 for interface dimensions.

DGMFN-5-X Dual Flow Control

mm (inches)

