

GRUP 20 POMPALARIN KODLAMA SİSTEMİ
ORDERING CODE OF GROUP 20 PUMPS

AP20 . 115/115/115 . C A B 02 S O N - T

Eleman sayısı

	Tekil Single
T	Tandem Tandem
M	Modüler Modular

Keçe / Seal

N	NBR
V	Viton

Pompa Tipi / Pump Type	İletim Hacmi / Displacement cm ³ /dev (cm ³ /rev)
AP20 Alüminyum Gövdeli Düz Dişli Pompa Aluminium Body Gear Pump	040 = 3,9 cm ³ /dev (cm ³ /rev) 060 = 5,9 cm ³ /dev (cm ³ /rev)
APH20 Alüminyum Gövdeli Helisel Dişli Pompa Aluminium Body Helical Gear Pump	080 = 8,0 cm ³ /dev (cm ³ /rev) 095 = 9,4 cm ³ /dev (cm ³ /rev)
DKP20 Döküm Gövdeli Düz Dişli Pompa Cast Iron Body Gear Pump	115 = 11,4 cm ³ /dev (cm ³ /rev) 140 = 13,9 cm ³ /dev (cm ³ /rev)
DPH20 Döküm Gövdeli Helisel Dişli Pompa Cast Iron Body Helical Gear Pump	160 = 16,0 cm ³ /dev (cm ³ /rev) 190 = 19,2 cm ³ /dev (cm ³ /rev) 220 = 21,9 cm ³ /dev (cm ³ /rev) 250 = 24,8 cm ³ /dev (cm ³ /rev) 280 = 27,9 cm ³ /dev (cm ³ /rev) 320 = 32,0 cm ³ /dev (cm ³ /rev) 340 = 34,0 cm ³ /dev (cm ³ /rev) 380 = 38,0 cm ³ /dev (cm ³ /rev) 400 = 40,0 cm ³ /dev (cm ³ /rev)

Dönüş Yönü / Rotation
A = Sol dönüş / Counter-clockwise
C = Sağ dönüş / Clockwise
R = Çift dönüş / Reversible

Arka Kapak / Rear Cover
S Standart Standard
R1 Emniyet Valfi (10 - 90 Bar) Relief Valve
R2 Emniyet Valfi (70 - 140 Bar) Relief Valve
R3 Emniyet Valfi (120 - 190 Bar) Relief Valve
D Akış Bölücü Valf Flow Divider Valve
H Emniyet Valfi Akış Kontrol Valfi Flow Control Valve With Relief Valve
L Yük Duyarlı Valf Load Sensing Valve
T Çek Valf Check Valve
P Arkadan Giriş-Çıkış Rear Inlet-Outlet
C Basınç Kompansatörlü Akış Kontrol Valfi Flow Control Valve Pressure Compensated

Ön Kapak / Front Cover
A Dikdörtgen kapak Square flange Ø36,47 mm
B 2 Civatalı - Merkezleme 2 Bolts - Centering Ø50 mm
C 2 Civatalı - Merkezleme ve oringli 2 Bolts - Centering with oring Ø52 mm
D 2 Civatalı SAE 'A' 2 Bolts SAE 'A' Ø82,55 mm
E 2 Civatalı - Merkezleme 2 Bolts - Centering Ø50 mm
G Dikdörtgen kapak Square flange Ø80 mm
H Ön yataklı Outboard bearing Ø80 mm
K 2 Civatalı SAE 'B' 2 Bolts SAE 'B' Ø101,6 mm
M 2 Civatalı - Merkezleme 2 Bolts - Centering Ø52,34 mm
N 4 Civatalı - Merkezleme O-ringli 4 Bolts - Centering O-ring Ø52 mm

Tahrik Şaftı / Drive Shaft
A Konik - Kamalı Tapered key shaft 1:5
B Konik - Kamalı Tapered key shaft 1:8
C SAE spline şaft 9 diş SAE spline shaft 9T
E Kesik şaftlı Tang drive shaft
F SAE spline şaft 11 diş SAE spline shaft 11T
G Spline şaft DIN 5482 Spline shaft (B17x14)
H Paralel şaft Parallel shaft
K Konik - Kamalı Tapered key shaft 1:5
L Konik - Kamalı Tapered key shaft 1:5
M SAE spline şaft J498 10 diş SAE spline shaft 16/32 DP 10T
N Konik - Kamalı Tapered key shaft 1:8
T Kesik şaftlı Tang drive shaft

Giriş - Çıkış Delikleri / Inlet and Outlet Ports
01 Kare tip Rectangular
02 Baklava tip Diamond
03 Metrik dişli ISO 6149 oring boss
04 UNF diş UNF thread
05 Boru diş Pipe thread
06 SAE Dikdörtgen Flanş Metrik diş SAE Square Flange Thread Metric

- Kodlama Örneği (Tekli) ; AP20.115.CAB02SN
Code Example (Single)

- Kodlama Örneği (Tandem) ; AP20.115/115/115.CAB02SN-T
Code Example (Tandem)

- Kodlama Örneği (Modüler) ; AP20.115/115/115.CAB02SN-M
Code Example (Modular)

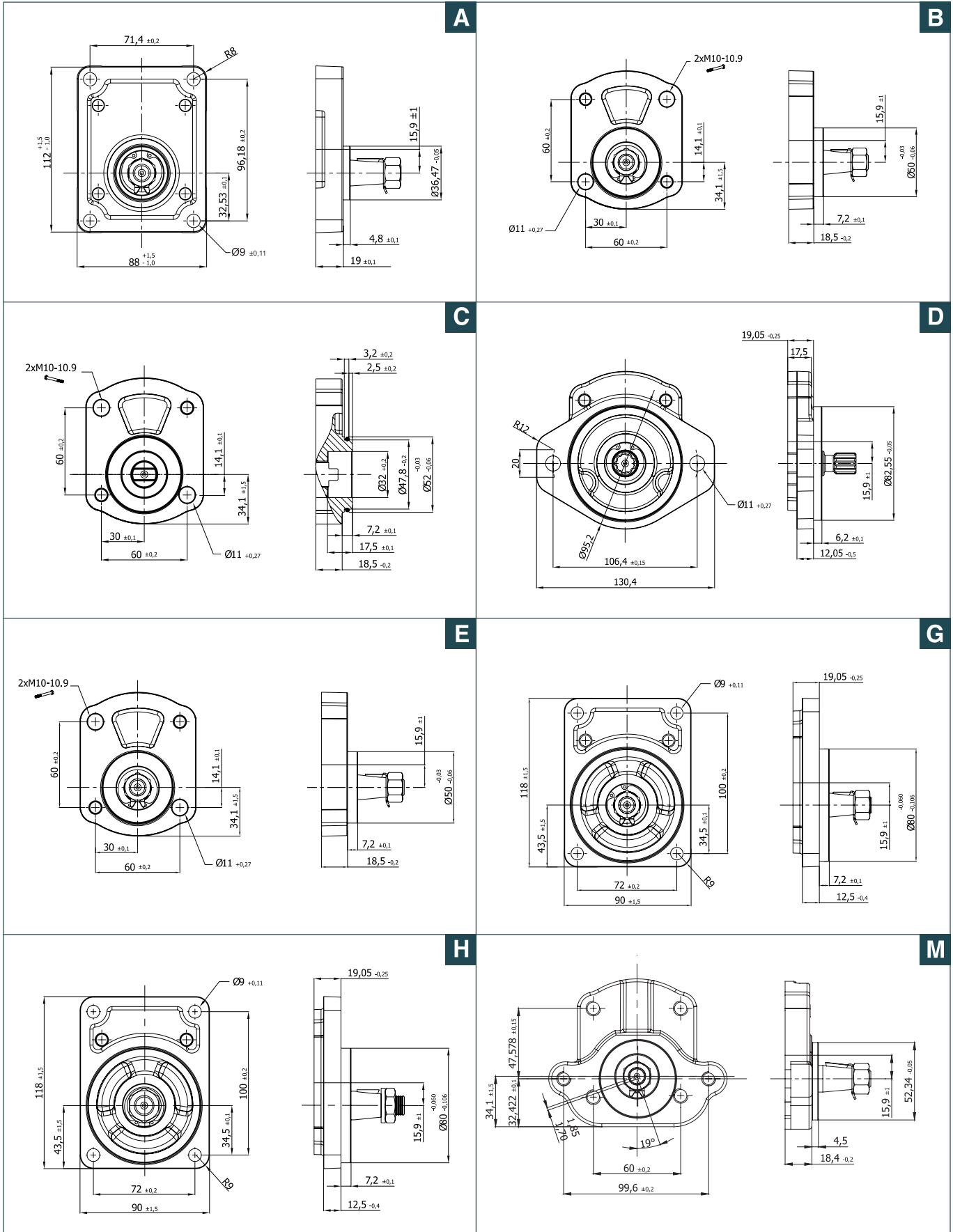

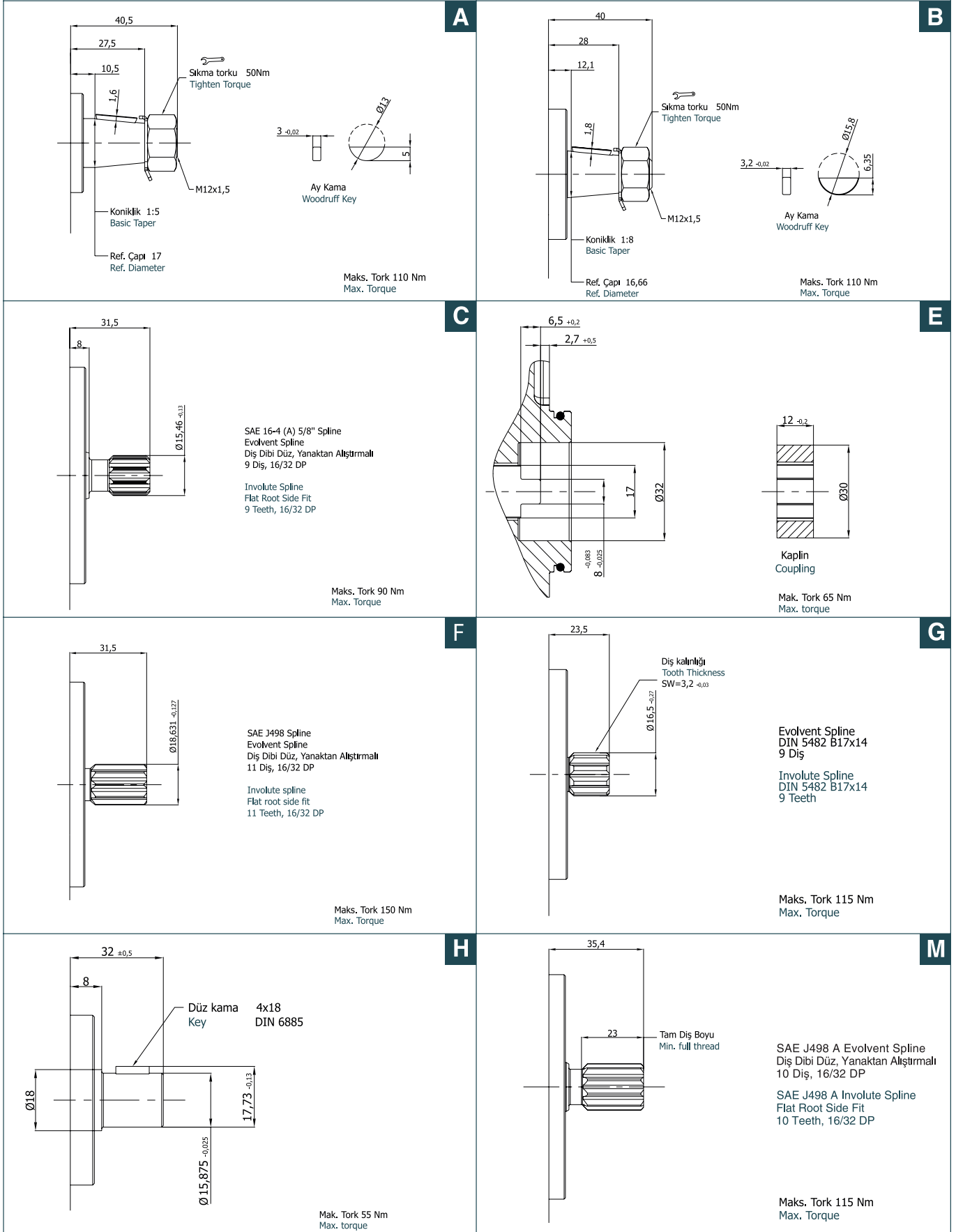

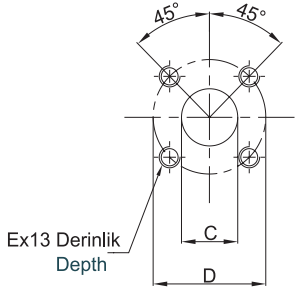

01 Kare Tipi Flaş
Rectangular Flange

Sipariş Kodu Ordering Code	İletim Hacmi Displacement cm ³ /dev (rev)	Emiş Tarafı Suction Side			Basınç Tarafı Pressure Side		
		C	D	E	c	d	e
01	4	12	40	M6	12	35	M6
	6	13,5			13,5		
	8 – 25	20			15		
	28 – 40				20		

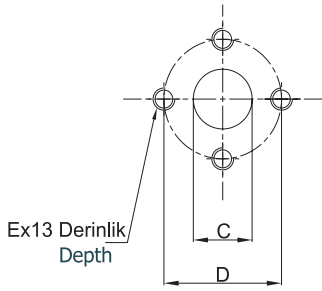

02 Baklava Tipi Flaş
Diamond Flange

Sipariş Kodu Ordering Code	İletim Hacmi Displacement cm ³ /dev (rev)	Emiş Tarafı Suction Side			Basınç Tarafı Pressure Side						
		C	D	E	c	d	e				
02	4	12	30,2	M6	12	30,2	M6				
	6 – 8	13,5			13,5						
	9,5 – 25	20			40			M8	20	40	M8
	28 – 40										

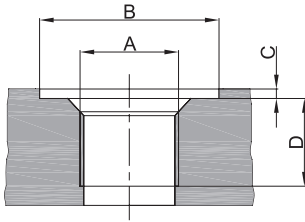

03 Metrik diş / Thread, Oring Boss
Metric ISO 6149 With Seal Ring

Sipariş Kodu Ordering Code	İletim Hacmi Displacement cm ³ /dev (rev)	Emiş Tarafı Suction Side				Basınç Tarafı Pressure Side			
		A	B	C	D	A	B	C	D
03	4 – 6	M18x1,5	30	0,5	16	M18x1,5	30	0,5	16
	8 – 16	M27x2	40		19	M22x1,5	35		19
	19 – 40	M33x2	45		22				

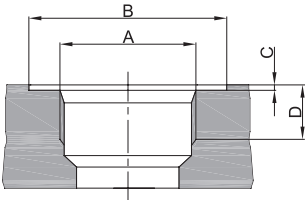

04 Diş / Thread
(UNF-2B) SAE Oring Boss

Sipariş Kodu Ordering Code	İletim Hacmi Displacement cm ³ /dev (rev)	Emiş Tarafı Suction Side				Basınç Tarafı Pressure Side			
		A	B	C	D	A	B	C	D
04	4 – 6	9/16-18 UNF-2B	25	0,5	13	9/16-18 UNF-2B	25	0,5	13
	8	7/8-14 UNF-2B	35		16	7/8-14 UNF-2B	35		16
	9,5 – 28	1 1/16-12 UN-2B	45		19				
	32 – 40								

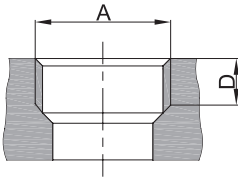

05 Boru diş / Pipe Thread
ISO228/1

Sipariş Kodu Ordering Code	İletim Hacmi Displacement cm ³ /dev (rev)	Emiş Tarafı Suction Side		Basınç Tarafı Pressure Side	
		A	D	A	D
05	4 – 16	G ¾	16	G ½	16
	19 – 40	G 1	19	G ¾	

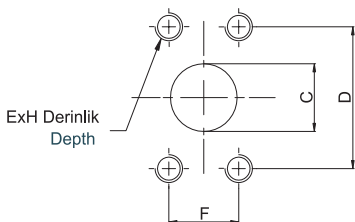

06 SAE Dikdörtgen Flaş Metrik Diş
SAE Square Flange Metric Thread

Sipariş Kodu Ordering Code	İletim Hacmi Displacement cm ³ /dev (rev)	Emiş Tarafı Suction Side					Basınç Tarafı Pressure Side				
		C	D	E	F	H	c	d	e	f	h
06	4 - 11,5	12	38,1	M8	17,5	13	12	38,1	M8	17,5	13
	14 - 19	20	47,6		22,2	16					
	22 - 40	26	52,4	26,2	20						

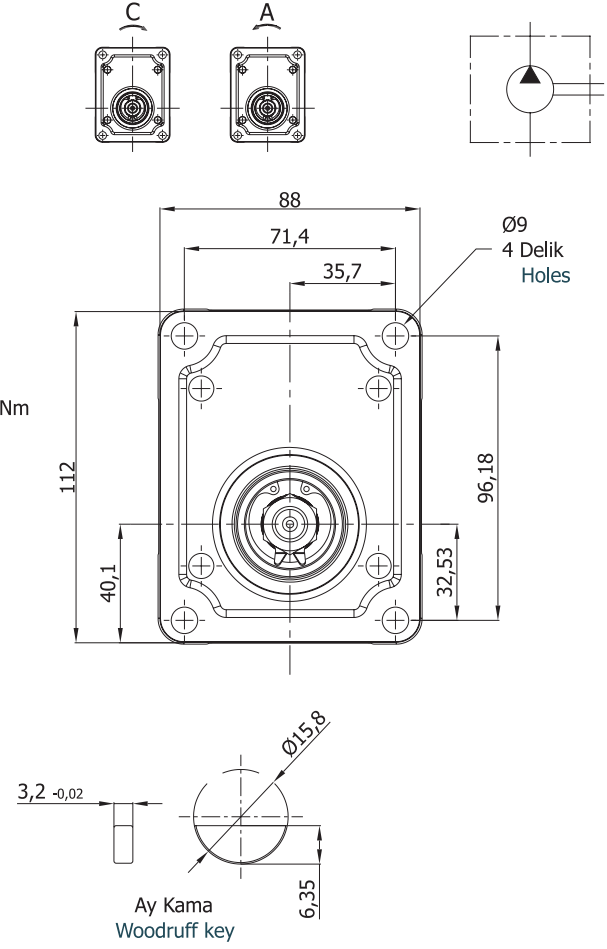
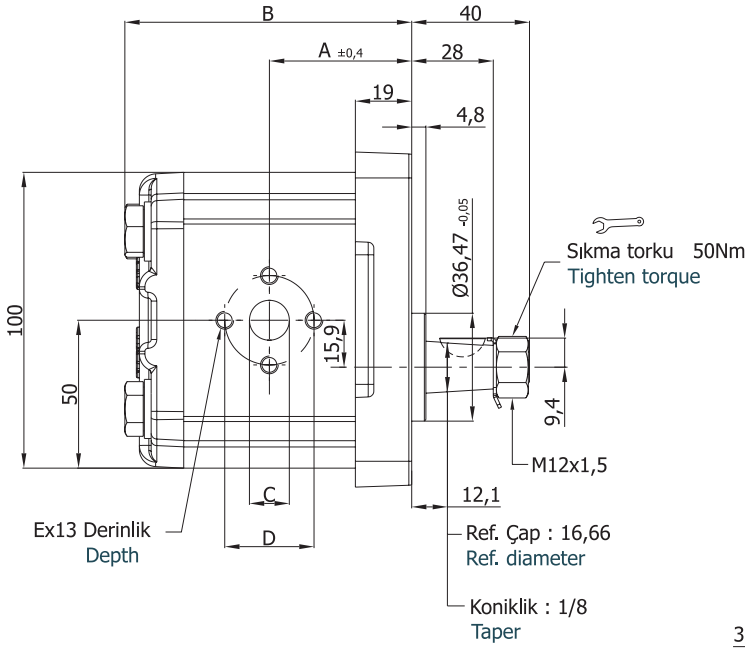
A Ön Kapak
Front Cover**B** Şaft Tipi
Shaft Type

Pompa Tipi Pump Type	İletim Hacmi Displacement cm ³ /dev(cm ³ /rev)	Maks. Basınç Max. Pressure (bar)	Maks. Hız Max. Speed d/d (rpm)	A _{±0,4}	B	Giriş – Inlet			Çıkış - Outlet			
						C	D	E	c	d	e	
DKP20.040.A/CAB02SN	3,9	280	3500	42,2	85,3	12	30,2	M6	12	30,2	M6	
DKP20.060.A/CAB02SN	5,9			43,8	88,4	13,5			M6			13,5
DKP20.080.A/CAB02SN	8,0			45,4	91,6							
DKP20.095.A/CAB02SN	9,4			46,5	93,9	20			40			M8
DKP20.115.A/CAB02SN	11,4		3000	48,2	97,0		20	40				
DKP20.140.A/CAB02SN	13,9			50,0	101,0	20			40			M8
DKP20.160.A/CAB02SN	16,0		51,7	104,1	2500		20	40				
DKP20.190.A/CAB02SN	19,2		60,2	121,1		2200			20			40
DKP20.220.A/CAB02SN	21,9	240	62,3	125,5	20		40	M8				
DKP20.250.A/CAB02SN	24,8	220	64,8	130,4		20			40	M8		
DKP20.280.A/CAB02SN	27,9	200	67,0	134,9	20		40	M8				

B Ön Kapak
Front Cover

G Şaft Tipi
Shaft Type

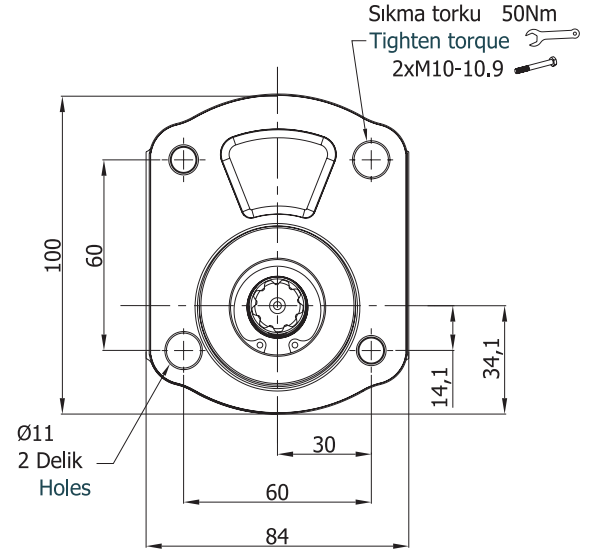
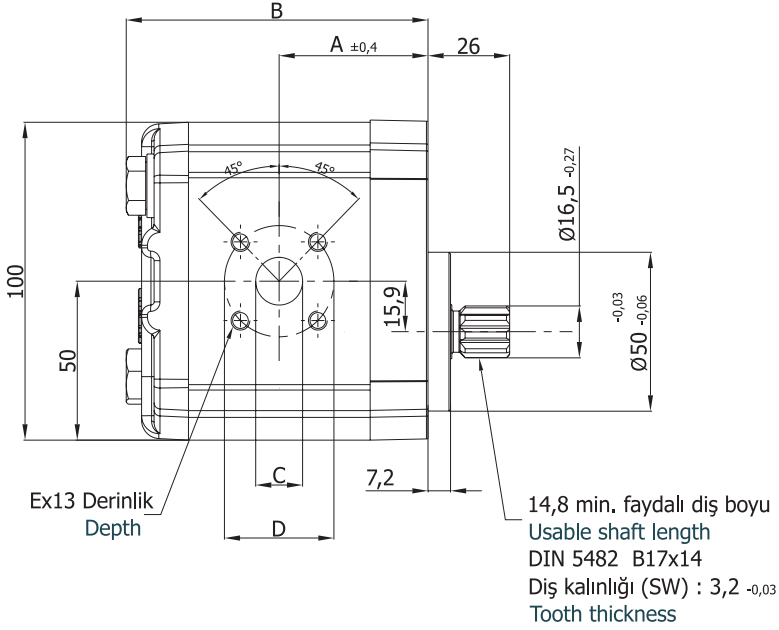
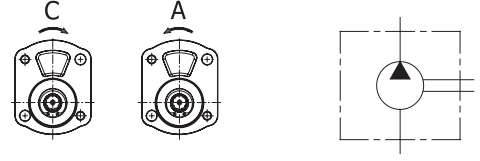

Pompa Tipi Pump Type	İletim Hacmi Displacement cm ³ /dev(cm ³ /rev)	Maks. Basınç Max. Pressure (bar)	Maks. Hız Max. Speed d/d (rpm)	A ±0,4	B	Giriş – Inlet			Çıkış - Outlet					
						C	D	E	c	d	e			
DKP20.040.A/CBG01SN	3,9	280	3500	41,6	84,7	12	40	M6	12	35	M6			
DKP20.060.A/CBG01SN	5,9			43,2	87,8	13,5			13,5					
DKP20.080.A/CBG01SN	8,0			44,8	91,0	20			15					
DKP20.095.A/CBG01SN	9,4			45,9	93,3									
DKP20.115.A/CBG01SN	11,4		3000	2500	47,6	96,4			20			15	20	40
DKP20.140.A/CBG01SN	13,9				49,4	100,4								
DKP20.160.A/CBG01SN	16,0				51,1	103,5								
DKP20.190.A/CBG01SN	19,2				59,6	120,5								
DKP20.220.A/CBG01SN	21,9	240	2500	61,7	124,9	20	20	40						
DKP20.250.A/CBG01SN	24,8	220		64,2	129,8									
DKP20.280.A/CBG01SN	27,9	200	2200	66,4	134,3	20	20	40						

C Ön Kapak
Front Cover

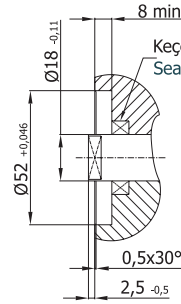
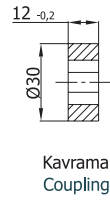
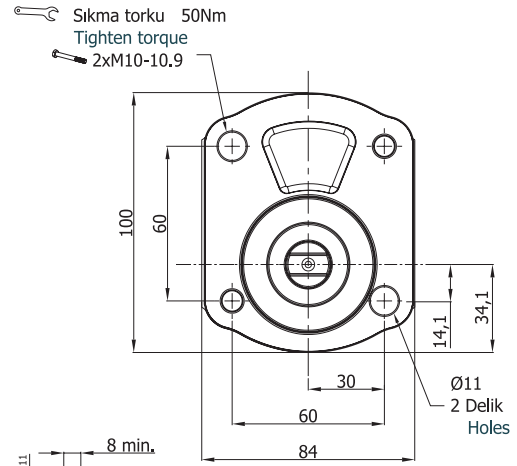
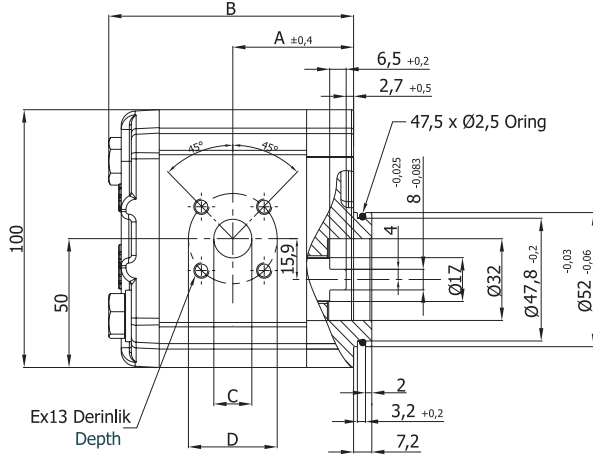
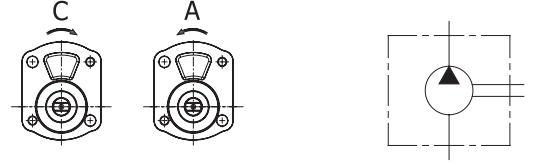
E Şaft Tipi
Shaft Type

Pompa Tipi Pump Type	İletim Hacmi Displacement cm ³ /dev(cm ³ /rev)	Maks. Basınç Max. Pressure (bar)	Maks. Hız Max. Speed d/d (rpm)	A ±0,4	B	Giriş – Inlet			Çıkış - Outlet		
						C	D	E	c	d	e
DKP20.040.A/CCE01SN	3,9	280	3500	41,6	84,7	12	40	M6	12	35	M6
DKP20.060.A/CCE01SN	5,9			43,2	87,8	13,5			13,5		
DKP20.080.A/CCE01SN	8,0			44,8	91,0	20			15		
DKP20.095.A/CCE01SN	9,4		45,9	93,3							
DKP20.115.A/CCE01SN	11,4		47,6	96,4							
DKP20.140.A/CCE01SN	13,9		49,4	100,4							
DKP20.160.A/CCE01SN	16,0		51,1	103,5	2500	20			40		
DKP20.190.A/CCE01SN	19,2	59,6	120,5								
DKP20.220.A/CCE01SN	21,9	240	2200	61,7	124,9	20	40				
DKP20.250.A/CCE01SN	24,8	220		64,2	129,8						
DKP20.280.A/CCE01SN	27,9	200		66,4	134,3						

D Ön Kapak
Front Cover

C Şaft Tipi
Shaft Type

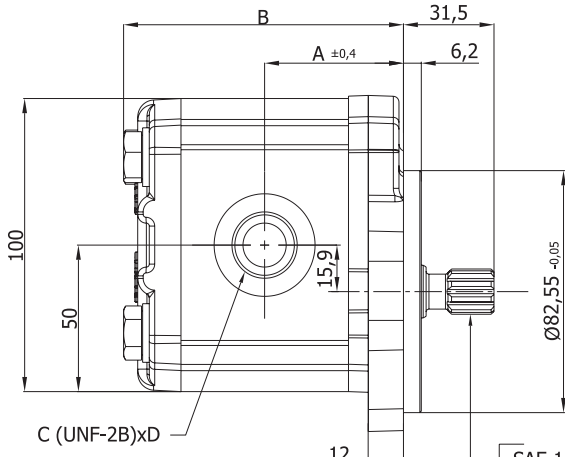
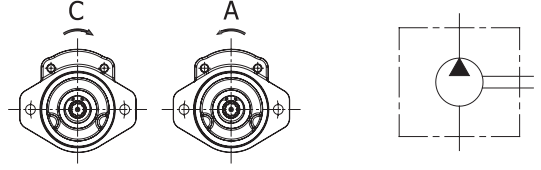

SAE 16-4 (A) 5/8" Spline
Evolvent Spline
Diş Dibi Düz, Yanaktan Alıştırmalı
9 Diş, 16/32 DP

Involute spline
Flat root side fit
9 Teeth, 16/32 DP

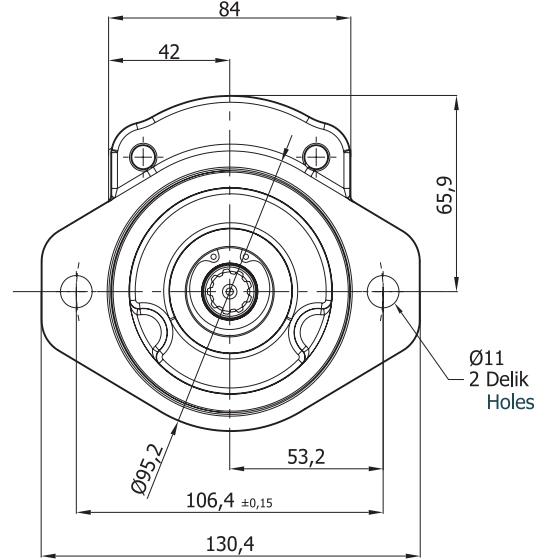

Pompa Tipi Pump Type	İletim Hacmi Displacement cm ³ /dev(cm ³ /rev)	Maks. Basınç Max. Pressure (bar)	Maks. Hız Max. Speed d/d (rpm)	A ±0,4	B	Giriş – Inlet		Çıkış - Outlet	
						C	D	c	d
DKP20.040.A/CDC04SN	3,9	280	3500	42,2	85,3	9/16-18 UNF	13	9/16-18 UNF	13
DKP20.060.A/CDC04SN	5,9			43,8	88,4				
DKP20.080.A/CDC04SN	8,0			45,4	91,6	7/8-14 UNF	16	7/8-14 UNF	16
DKP20.095.A/CDC04SN	9,4			46,5	93,9				
DKP20.115.A/CDC04SN	11,4			48,2	97,0	1 1/16-12 UNF	19	7/8-14 UNF	16
DKP20.140.A/CDC04SN	13,9			50,0	101,0				
DKP20.160.A/CDC04SN	16,0			51,7	104,1				
DKP20.190.A/CDC04SN	19,2			60,2	121,1				
DKP20.220.A/CDC04SN	21,9			62,3	125,5				
DKP20.250.A/CDC04SN	24,8			220	2500	64,8	130,4		
DKP20.280.A/CDC04SN	27,9	200	2200	67,0	134,9				