

GRUP 30 POMPALARIN KODLAMA SİSTEMİ
ORDERING CODE OF GROUP 30 PUMPS- Kodlama Örneği (Tekli) ; AP30.340.CAB02SN
Code Example (Single)- Kodlama Örneği (Tandem) ; AP30.340/340/340.CAB02SN
Code Example (Tandem)

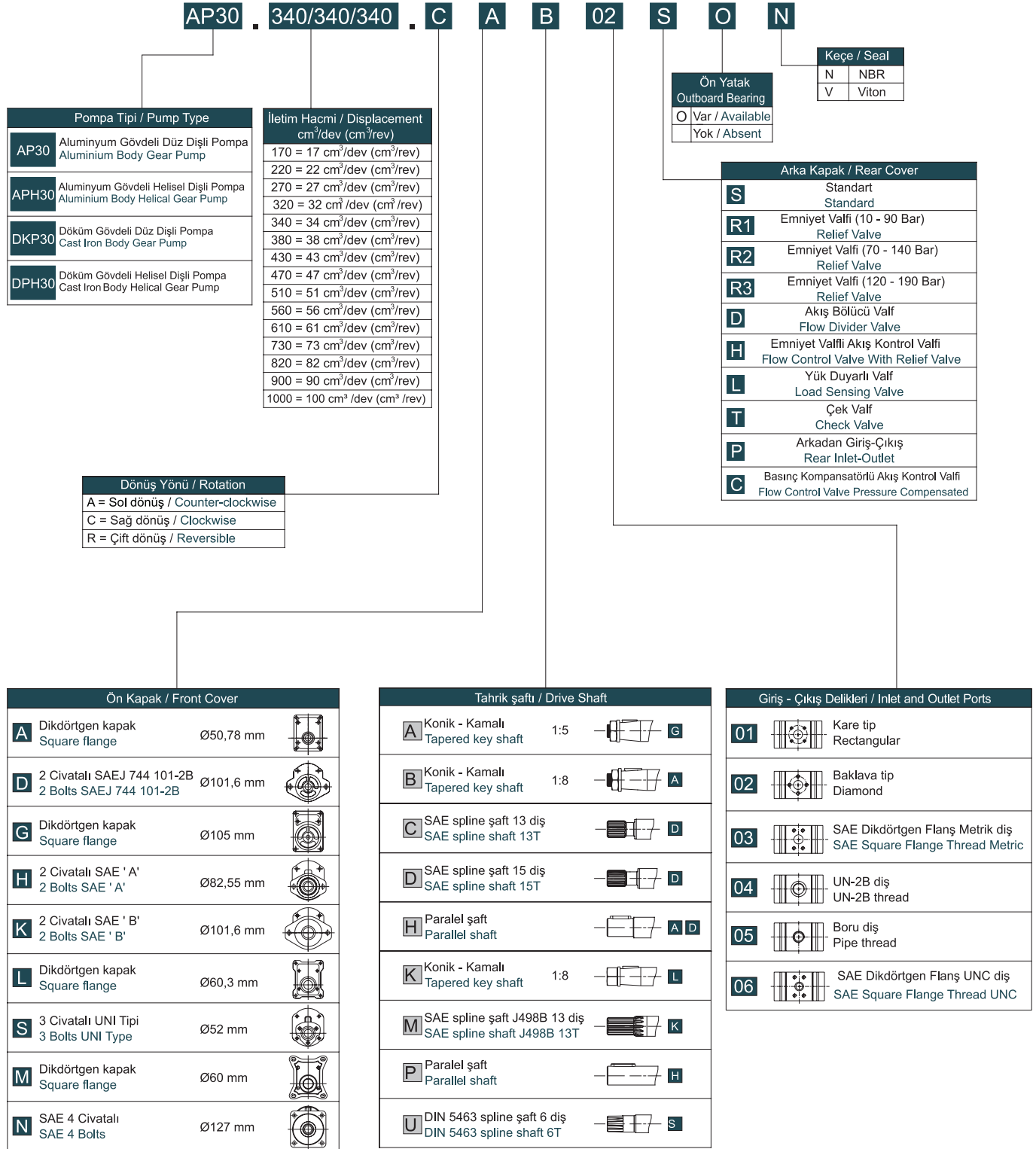

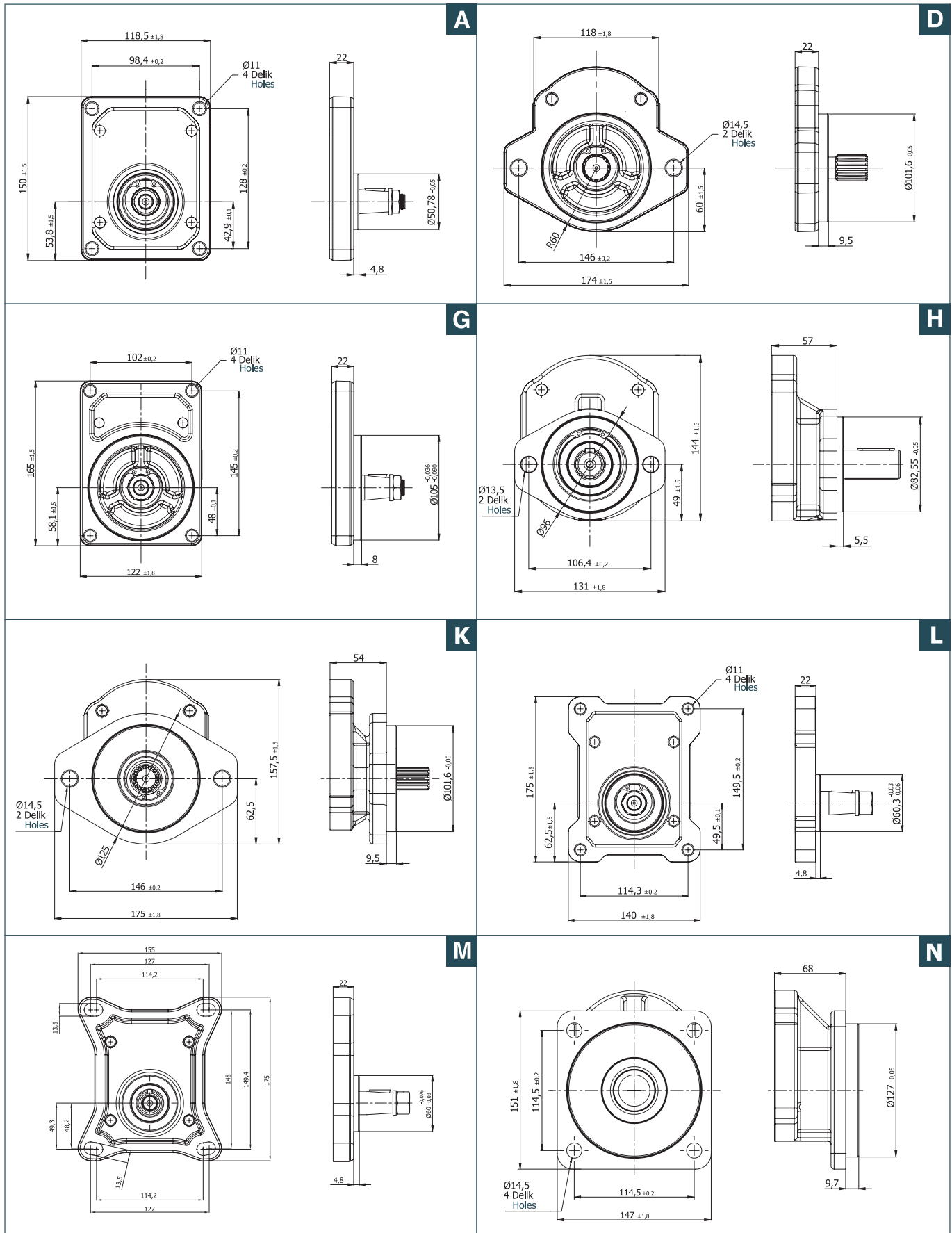

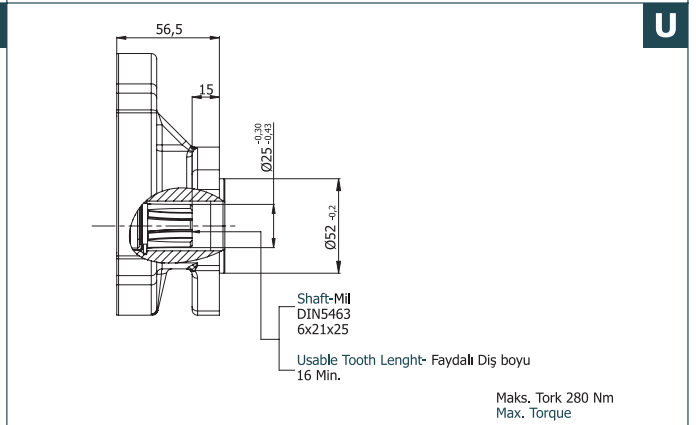
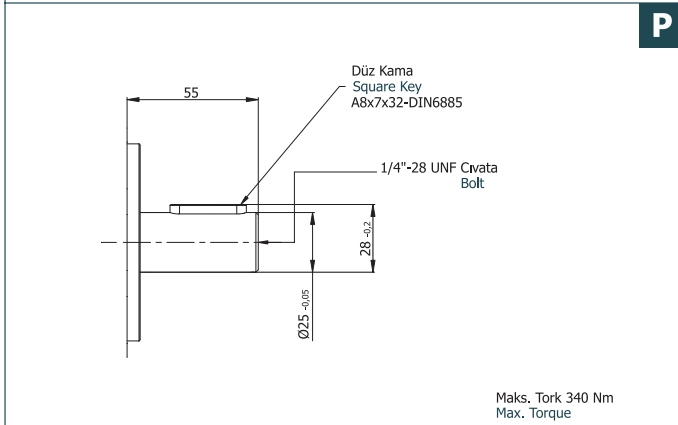
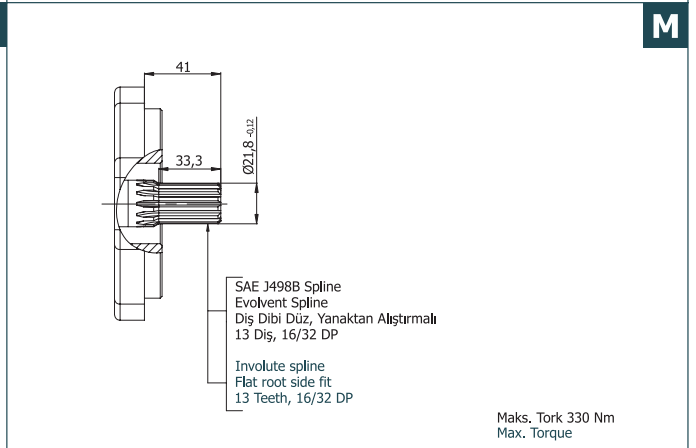
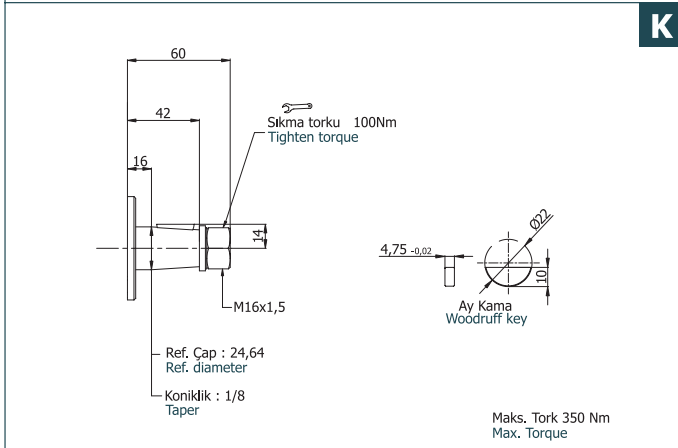
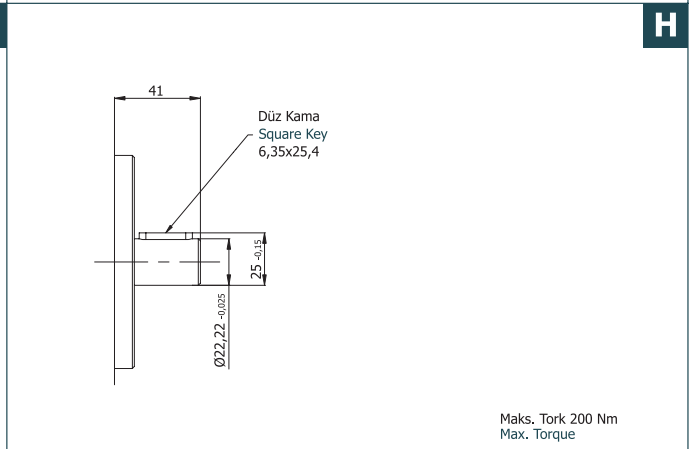
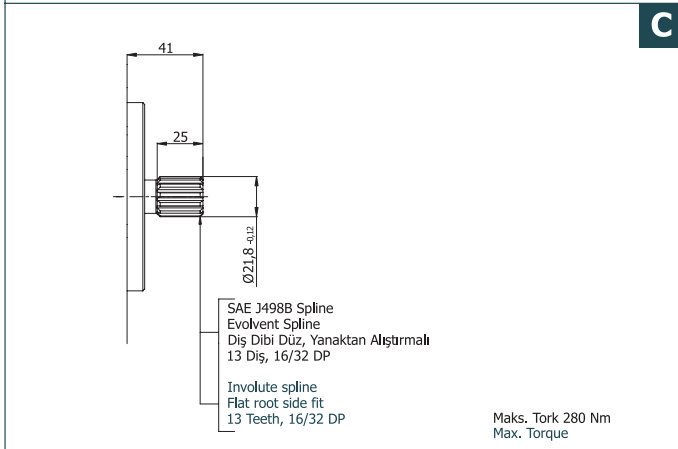
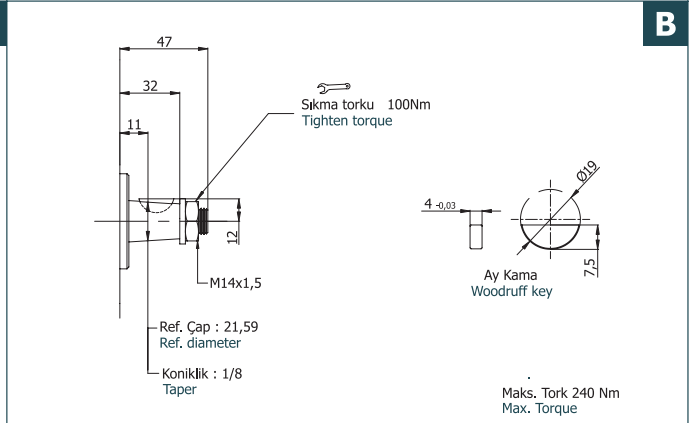
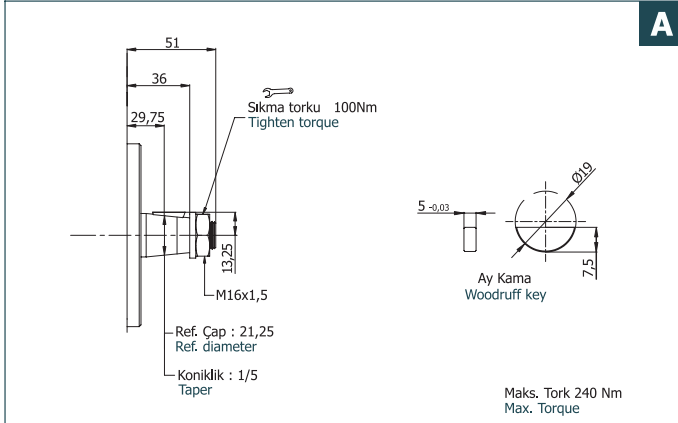
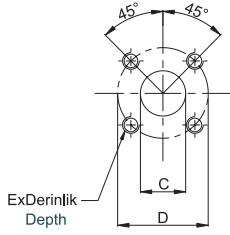

01 Kare Tipi Flanş Rectangular Flange

Sipariş Kodu Ordering Code	İletim Hacmi Displacement cm ³ /dev (rev)	Emiş Tarafı Suction Side			Basınç Tarafı Pressure Side		
		C	D	E	c	d	e
01	17 - 100	27	55	M8x16	19	55	M8x16

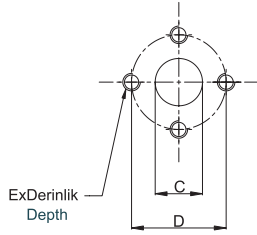

02 Baklava Tipi Flanş Diamond Flange

Sipariş Kodu Ordering Code	İletim Hacmi Displacement cm ³ /dev (rev)	Emiş Tarafı Suction Side			Basınç Tarafı Pressure Side		
		C	D	E	c	d	e
02	17 - 61	27	51	M10x19	19	40	M8x16
	73 - 100	33	62	M12x19	27	51	M10x19

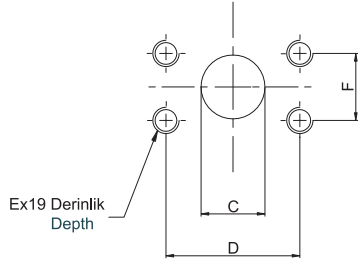

03 SAE Dikdörtgen Flanş Metrik Diş SAE Square Flange Metric Thread

Sipariş Kodu Ordering Code	İletim Hacmi Displacement cm ³ /dev (rev)	Emiş Tarafı Suction Side				Basınç Tarafı Pressure Side			
		C	D	E	F	c	d	e	f
03	17 - 22	19	47,6	M8	22,2	12,5	38,1	M8	17,5
	27 - 34	25,4	52,4	M10	26,2	19	47,6	M8	22,2
	38 - 51	30,5	58,7		30,2	25,4	52,4	M10	26,2
	56 - 82	39,3	69,8	M12	35,7	30,5	58,7	M10	30,2
	90 - 100	51	77,8		42,9	39,3	69,8	M12	35,7

04 Diş / Thread (UN-2B) SAE Oring Boss

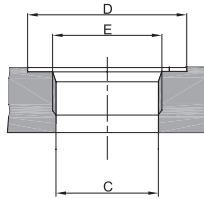

Sipariş Kodu Ordering Code	İletim Hacmi Displacement cm ³ /dev (rev)	Emiş Tarafı Suction Side			Basınç Tarafı Pressure Side		
		C	D	E	c	d	e
04	17 - 34	30,5	49	1 5/16"-12 UN-2B	24,8	42	1 1/16"-12 UN-2B
	38 - 51	39,1	58	1 5/8"-12 UN-2B	30,5	49	1 5/16"-12 UN-2B
	56 - 100	45	65	1 7/8"-12 UN-2B	39,1	58	1 5/8"-12 UN-2B

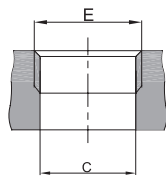

05 Boru diş / Pipe Thread ISO228/1

Sipariş Kodu Ordering Code	İletim Hacmi Displacement cm ³ /dev (rev)	Emiş Tarafı Suction Side		Basınç Tarafı Pressure Side	
		C	E	c	e
05	17 - 51	30,5	G 1	30,5	G 1
	56 - 73	39	G 1 1/4		
	82 - 100	45	G 1 1/2	39	G 1 1/4

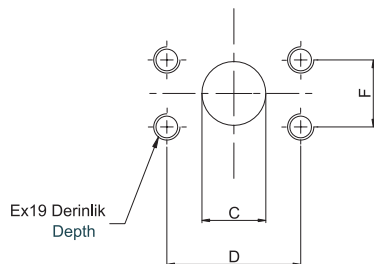

06 SAE Dikdörtgen Flanş UNC Diş SAE Square Flange UNC Thread

Sipariş Kodu Ordering Code	İletim Hacmi Displacement cm ³ /dev (rev)	Emiş Tarafı Suction Side			Basınç Tarafı Pressure Side				
		C	D	E	F	c	d	e	f
06	17 - 22	19	47,6	3/8-16 UNC-2B	22,2	12,5	38,1	5/16-18 UNC-2B	17,5
	27 - 34	25,4	52,4		26,2	19	47,6	3/8-16 UNC-2B	22,2
	38 - 51	30,5	58,7	7/16-14 UNC-2B	30,2	25,4	52,4		7/16-14 UNC-2B
	56 - 82	39,3	69,8	1/2-13 UNC-2B	35,7	30,5	58,7	1/2-13 UNC-2B	
	90 - 100	51	77,8		42,9	39,3	69,8		35,7

A Ön Kapak
Front Cover

B Şaft Tipi
Shaft Type

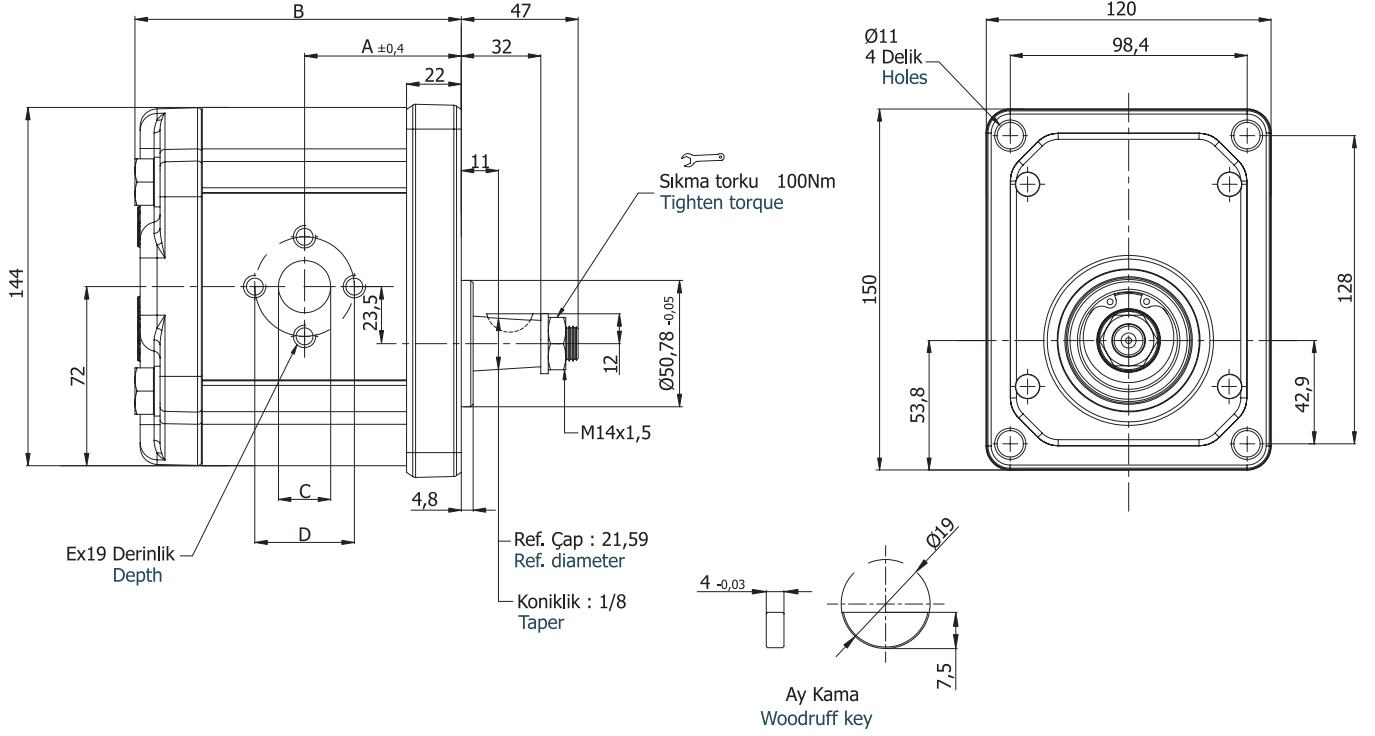
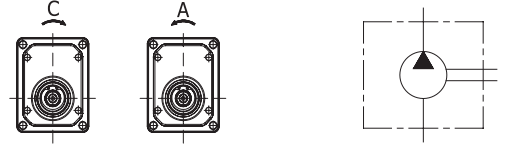

Pompa Tipi Pump Type	İletim Hacmi Displacement cm ³ /dev(cm ³ /rev)	Maks. Basınç Max. Pressure (bar)	Maks. Hız Max. Speed d/d (rpm)	A ±0,4	B	Giriş – Inlet			Çıkış - Outlet		
						C	D	E	c	d	e
DKP30.170.A/CAB02SN	17,0	280	3000	59,5	124,1	27	51	M10x19	19	40	M8x16
DKP30.220.A/CAB02SN	22,0			61,5	128,1						
DKP30.270.A/CAB02SN	27,0			63,0	131,1						
DKP30.320.A/CAB02SN	32,0	260		64,5	134,1						
DKP30.340.A/CAB02SN	34,0			65,0	135,1						
DKP30.380.A/CAB02SN	38,0			66,5	138,1						
DKP30.430.A/CAB02SN	43,0	250	2500	68,0	141,1	27	62	M12x19	27	51	M10x19
DKP30.470.A/CAB02SN	47,0			69,5	144,1						
DKP30.510.A/CAB02SN	51,0			70,5	146,1						
DKP30.560.A/CAB02SN	56,0	230		71,5	148,1						
DKP30.610.A/CAB02SN	61,0			74,0	153,1						
DKP30.730.A/CAB02SN	73,0			77,0	160,1						
DKP30.820.A/CAB02SN	82,0	190	1500	80,0	166,1	33	62	M12x19	27	51	M10x19
DKP30.900.A/CAB02SN	90,0			83,0	172,1						
DKP30.1000.A/CAB02SN	100,0			86,0	178,1						

A Ön Kapak
Front Cover

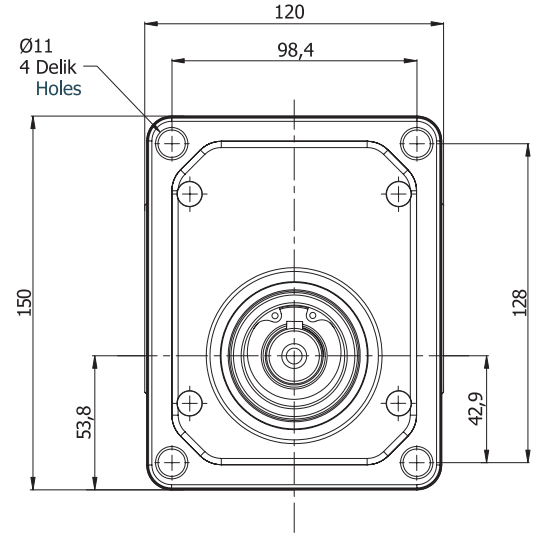
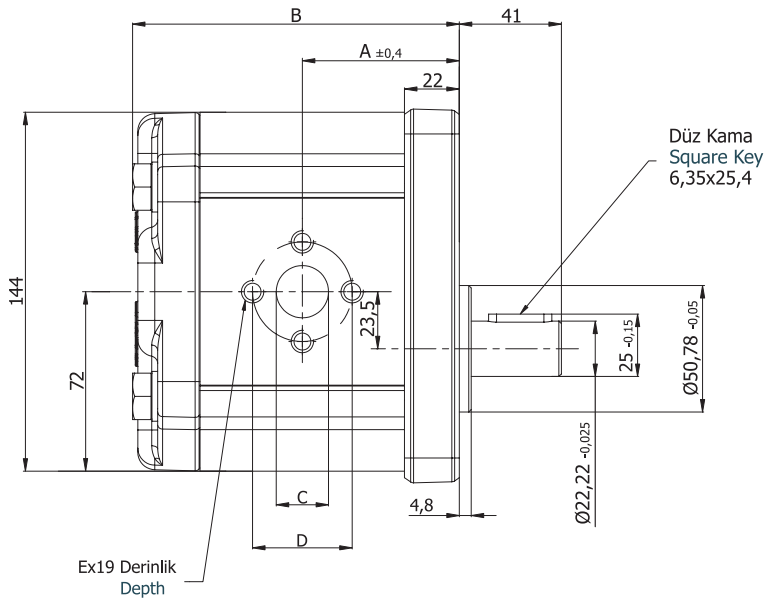
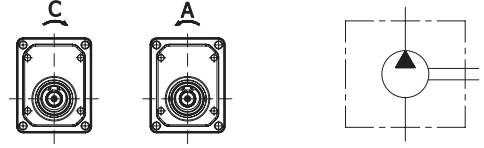
H Şaft Tipi
Shaft Type

Pompa Tipi Pump Type	İletim Hacmi Displacement cm ³ /dev(cm ³ /rev)	Maks. Basınç Max. Pressure (bar)	Maks. Hız Max. Speed d/d (rpm)	A ±0,4	B	Giriş – Inlet			Çıkış - Outlet			
						C	D	E	c	d	e	
DKP30.170.A/CAH02SN	17,0	280	3000	59,5	124,1	27	51	M10x19	19	40	M8x16	
DKP30.220.A/CAH02SN	22,0			61,5	128,1							
DKP30.270.A/CAH02SN	27,0			63,0	131,1							
DKP30.320.A/CAH02SN	32,0	64,5		134,1								
DKP30.340.A/CAH02SN	34,0	65,0		135,1								
DKP30.380.A/CAH02SN	38,0	66,5		138,1								
DKP30.430.A/CAH02SN	43,0	68,0	141,1	250	144,1	27	51	M10x19	19	40	M8x16	
DKP30.470.A/CAH02SN	47,0	69,5	144,1									
DKP30.510.A/CAH02SN	51,0	70,5	146,1									
DKP30.560.A/CAH02SN	56,0	71,5	148,1									
DKP30.610.A/CAH02SN	61,0	74,0	153,1									
DKP30.730.A/CAH02SN	73,0	77,0	160,1									2000
DKP30.820.A/CAH02SN	82,0	190	80,0									
DKP30.900.A/CAH02SN	90,0	180	83,0	172,1								
DKP30.1000.A/CAH02SN	100,0		86,0	178,1								

D Ön Kapak
Front Cover

C Şaft Tipi
Shaft Type

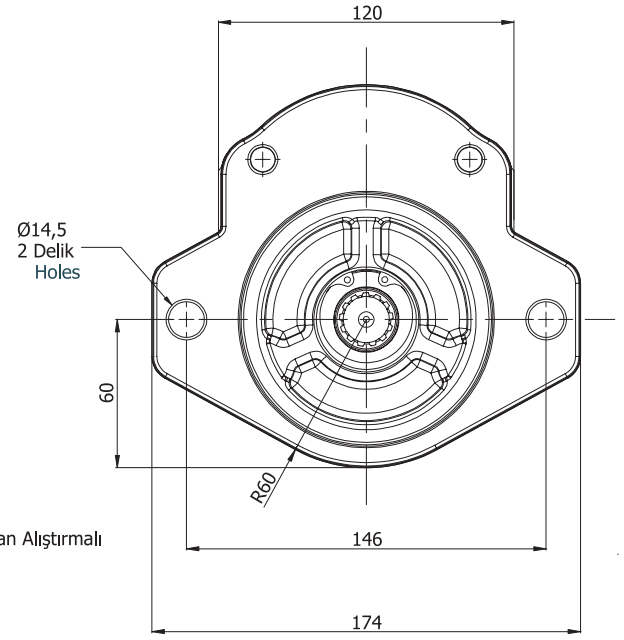
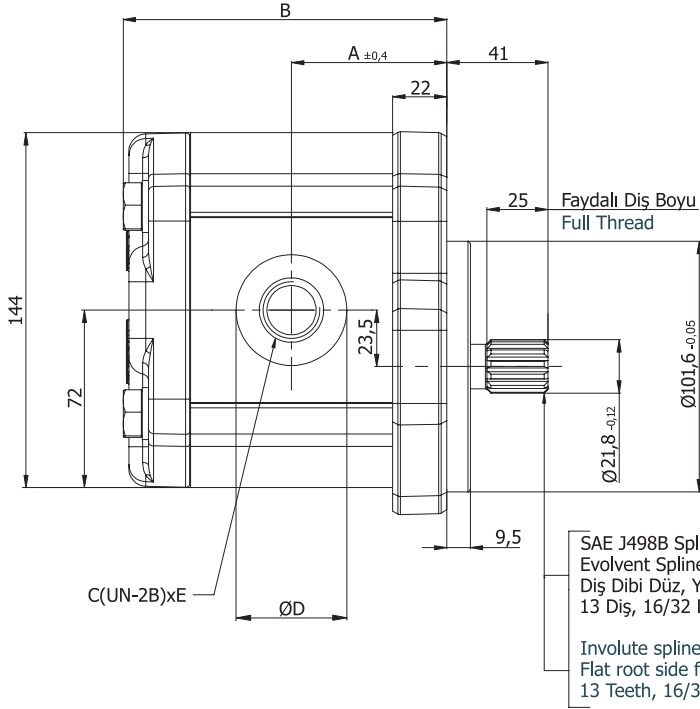
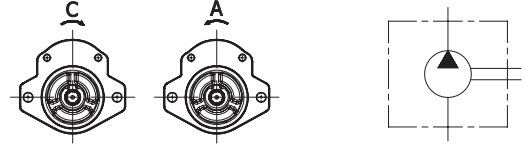

Pompa Tipi Pump Type	İletim Hacmi Displacement cm ³ /dev(cm ³ /rev)	Maks. Basınç Max. Pressure (bar)	Maks. Hız Max. Speed d/d (rpm)	A $\pm 0,4$	B	Giriş – Inlet			Çıkış - Outlet		
						C	D	E	c	d	e
DKP30.170.A/CDC04SN	17,0	280	3000	59,5	124,1	30,5	49	1 5/16"-12 UNF-2B	24,8	42	1 1/16"-12 UNF-2B
DKP30.220.A/CDC04SN	22,0			61,5	128,1						
DKP30.270.A/CDC04SN	27,0			63,0	131,1						
DKP30.320.A/CDC04SN	32,0			64,5	134,1						
DKP30.340.A/CDC04SN	34,0			65,0	135,1						
DKP30.380.A/CDC04SN	38,0	260	3000	66,5	138,1	39,1	58	1 5/8"-12 UNF-2B	30,5	49	1 5/16"-12 UNF-2B
DKP30.430.A/CDC04SN	43,0			68,0	141,1						
DKP30.470.A/CDC04SN	47,0			69,5	144,1						
DKP30.510.A/CDC04SN	51,0			70,5	146,1						
DKP30.560.A/CDC04SN	56,0			71,5	148,1						
DKP30.610.A/CDC04SN	61,0	220	2500	74,0	153,1	45	65	1 7/8"-12 UNF-2B	39,1	58	1 5/8"-12 UNF-2B
DKP30.730.A/CDC04SN	73,0			77,0	160,1						
DKP30.820.A/CDC04SN	82,0			80,0	166,1						
DKP30.900.A/CDC04SN	90,0			83,0	172,1						
DKP30.1000.A/CDC04SN	100,0			86,0	178,1						

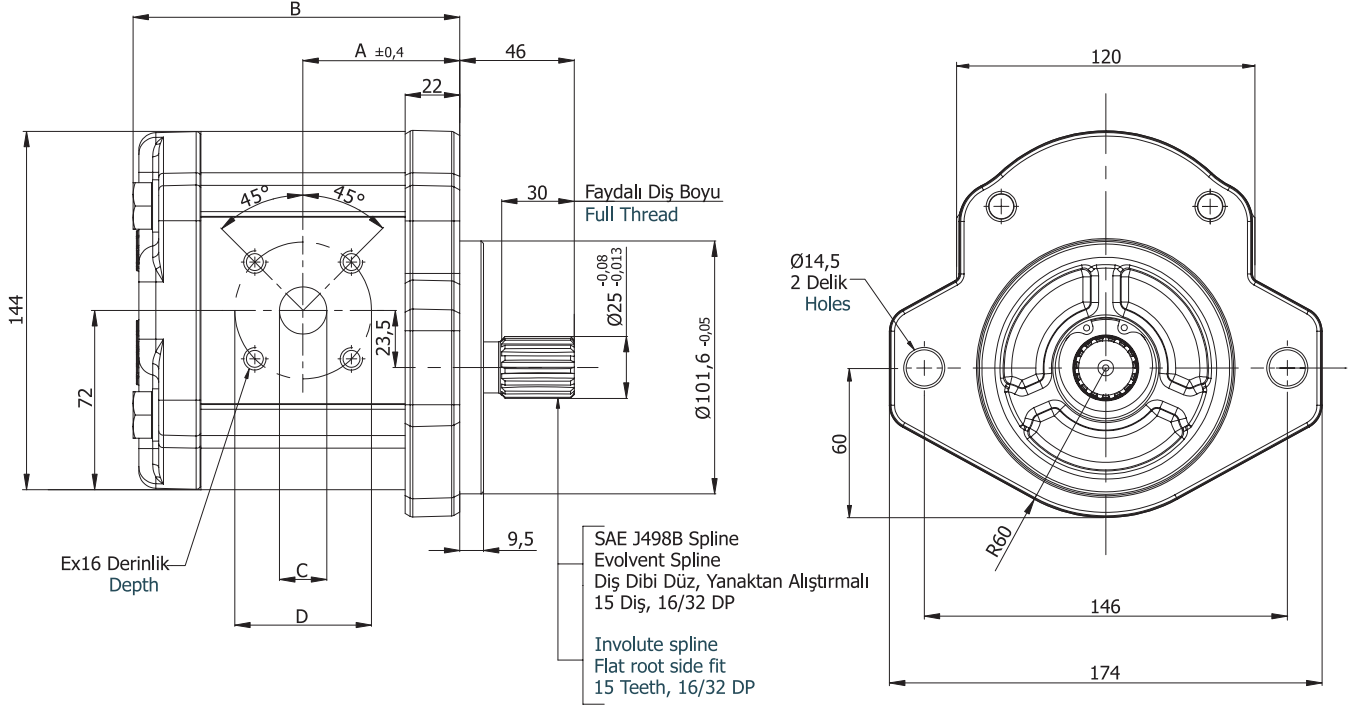
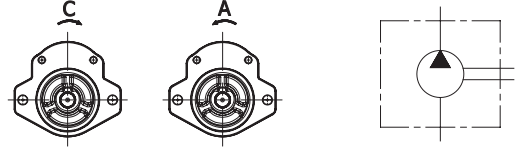
D Ön Kapak
Front Cover**D** Şaft Tipi
Shaft Type

Pompa Tipi Pump Type	İletim Hacmi Displacement cm ³ /dev(cm ³ /rev)	Maks. Basınç Max. Pressure (bar)	Maks. Hız Max. Speed d/d (rpm)	A ±0,4	B	Giriş – Inlet			Çıkış - Outlet		
						C	D	E	c	d	e
DKP30.170.A/CDD01SN	17,0	280	3000	59,5	124,1	27	55	M8x16	19	55	M8x16
DKP30.220.A/CDD01SN	22,0			61,5	128,1						
DKP30.270.A/CDD01SN	27,0			63,0	131,1						
DKP30.320.A/CDD01SN	32,0	260	3000	64,5	134,1						
DKP30.340.A/CDD01SN	34,0			65,0	135,1						
DKP30.380.A/CDD01SN	38,0			66,5	138,1						
DKP30.430.A/CDD01SN	43,0	250	2500	68,0	141,1						
DKP30.470.A/CDD01SN	47,0			69,5	144,1						
DKP30.510.A/CDD01SN	51,0			70,5	146,1						
DKP30.560.A/CDD01SN	56,0	230	2500	71,5	148,1						
DKP30.610.A/CDD01SN	61,0	220	2500	74,0	153,1						
DKP30.730.A/CDD01SN	73,0	200	2500	77,0	160,1						
DKP30.820.A/CDD01SN	82,0	190	2000	80,0	166,1						
DKP30.900.A/CDD01SN	90,0	180		83,0	172,1						
DKP30.1000.A/CDD01SN	100,0			86,0	178,1						

G Ön Kapak
Front Cover

A Şaft Tipi
Shaft Type

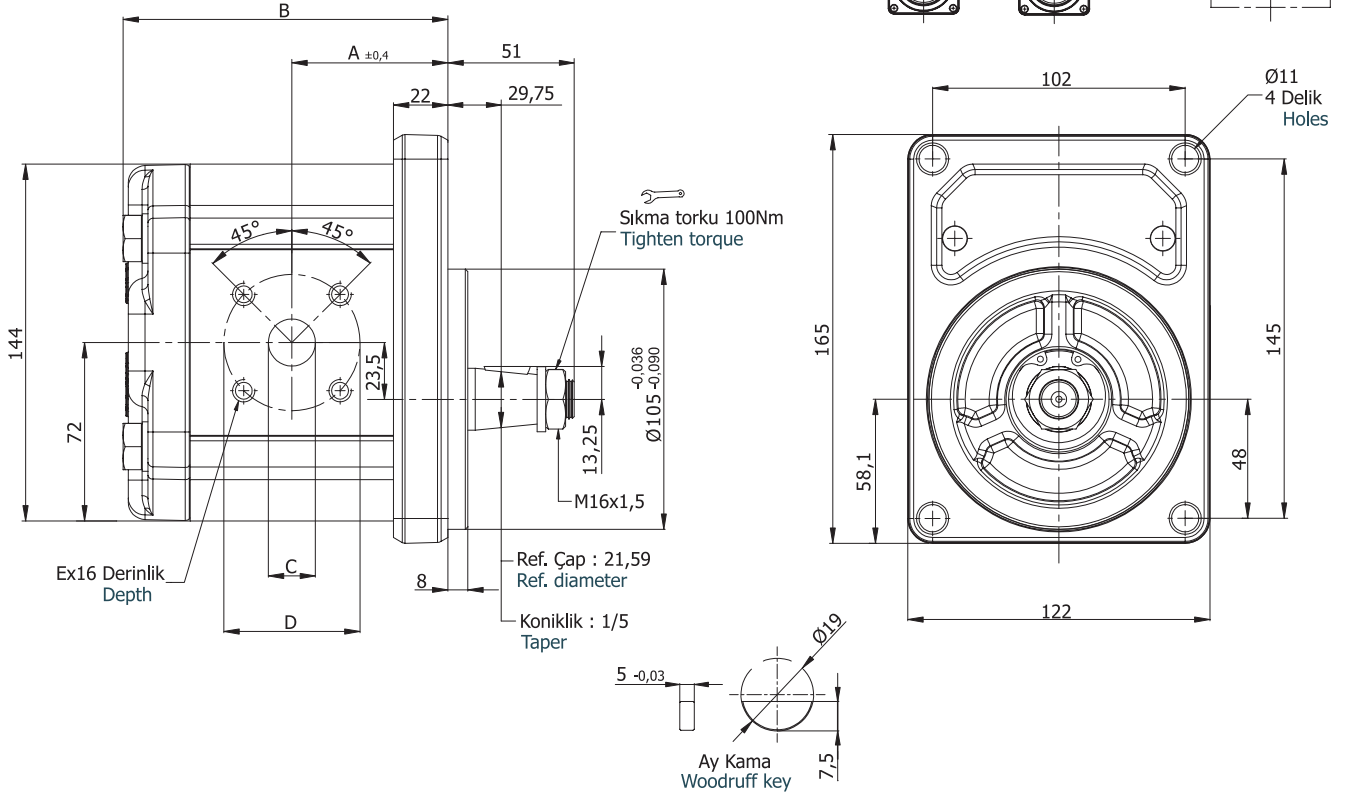
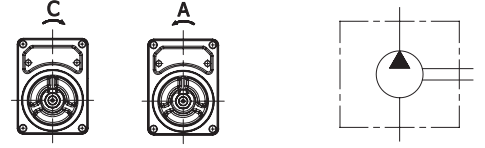

Pompa Tipi Pump Type	İletim Hacmi Displacement cm ³ /dev(cm ³ /rev)	Maks. Basınç Max. Pressure (bar)	Maks. Hız Max. Speed d/d (rpm)	A ±0,4	B	Giriş - Inlet			Çıkış - Outlet		
						C	D	E	c	d	e
DKP30.170.A/CGA01SN	17,0	280	3000	59,5	124,1	27	55	M8x16	19	55	M8x16
DKP30.220.A/CGA01SN	22,0			61,5	128,1						
DKP30.270.A/CGA01SN	27,0			63,0	131,1						
DKP30.320.A/CGA01SN	32,0	64,5		134,1							
DKP30.340.A/CGA01SN	34,0	65,0		135,1							
DKP30.380.A/CGA01SN	38,0	66,5		138,1							
DKP30.430.A/CGA01SN	43,0	250	2500	68,0	141,1	27	55	M8x16	19	55	M8x16
DKP30.470.A/CGA01SN	47,0			69,5	144,1						
DKP30.510.A/CGA01SN	51,0			70,5	146,1						
DKP30.560.A/CGA01SN	56,0	71,5		148,1							
DKP30.610.A/CGA01SN	61,0	74,0		153,1							
DKP30.730.A/CGA01SN	73,0	200		77,0	160,1						
DKP30.820.A/CGA01SN	82,0	190	2000	80,0	166,1	27	55	M8x16	19	55	M8x16
DKP30.900.A/CGA01SN	90,0	180		83,0	172,1						
DKP30.1000.A/CGA01SN	100,0	180		86,0	178,1						