

# ISE30 - Overcenter valve

www: [www.salushydraulics.pl](http://www.salushydraulics.pl)  
 e-mail: [pl@salushydraulics.pl](mailto:pl@salushydraulics.pl)  
 shop/sklep: [www.sklep.salushydraulics.pl](http://www.sklep.salushydraulics.pl)

Pilot assisted relief with check  
 30 L/min (8 USgpm) • 270 bar (4000 psi) Eaton 1SE30F35S2,5,10, Eaton 1SE30F20S2,5,10,

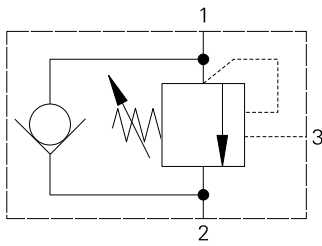

## Sectional view

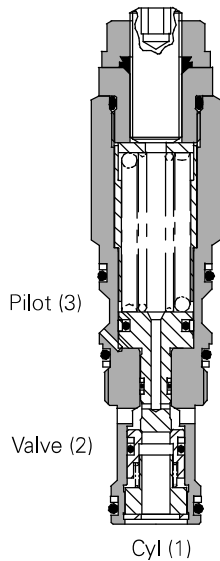

## Operation

The check section allows free flow into the actuator then holds and locks the load against movement. The pilot assisted relief valve section will give controlled movement when pilot pressure is applied. The relief section is normally set to open at a pressure at least 1.3 times the maximum load induced pressure but the pressure required to open the valve and allow movement

depends on the pilot ratio of the valve. For optimization of load control and energy usage, a choice of pilot ratios is available.

The pressure required to open the valve and start actuator movement can be calculated as follows:

$$\text{Pilot Pressure} = \frac{(\text{Relief Setting}) - (\text{Load Pressure})}{\text{Pilot Ratio}}$$

## Features

Cartridge is economical and fits simple cavity. Allows quick, easy field service - reduces down time. Interchangeable with pilot check valve of a similar size.

## Pilot ratio

2.5:1 Best suited for extremely unstable applications such as long booms or flexible frameworks.

5:1 (standard) Best suited for applications where load varies and machine structure can induce instability.

10:1 Best suited for applications where the load remains relatively constant.

## Performance data

### Ratings and specifications

Figures based on: Oil Temp = 40°C Viscosity = 32 cSt (150 SUS)

Rated flow	30 L/min (8 USgpm)
Max relief setting	350 bar (5000 psi)
Max load induced pressure	270 bar (4000 psi)
Cartridge material	Working parts hardened and ground steel. External steel surfaces zinc plated.
Mounting position	Unrestricted
Cavity number	A20090-T11A
Torque cartridge into cavity	45 Nm (33 lbs ft)
Weight	0.15 kg (0.33 lbs)
Seal kit number	SK1079 (Nitrile) SK1079V (Viton®)
Recommended filtration level	BS5540/4 Class 18/13 (25 micron nominal)
Operating temperature	-30° to +90°C (-22° to +194°F)
Leakage	0.3 milliliters/min nominal (5 dpm)
Nominal viscosity range	5 to 500 cSt

## Description

Overcenter valves give static and dynamic control of loads by regulating the flow into and out of hydraulic actuators. When installed close to or within an actuator, the overcenter valve will stop runaway in the event of hose burst and if open center directional control valves are used, will allow thermal expansion relief of the hydraulic fluid.

The overcenter cartridge is ideal for mounting directly into a cavity machined in the body of the cylinder, motor or rotary actuator. The cartridge can also be mounted directly to the ports via a specifically machined body as part of a Hydraulic Integrated Circuit or single unit, or contained within one of our standard line bodies.

Single overcenter valves are normally used when the load is unidirectional, for example an aerial platform or crane and dual overcenter valves are used for controlling loads in both directional for motor applications or for cylinders going over center.

## Pressure drop

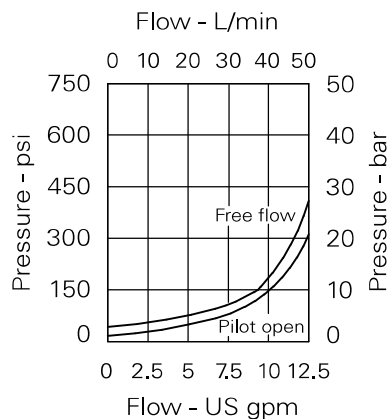

2:5:1 and 5:1 version

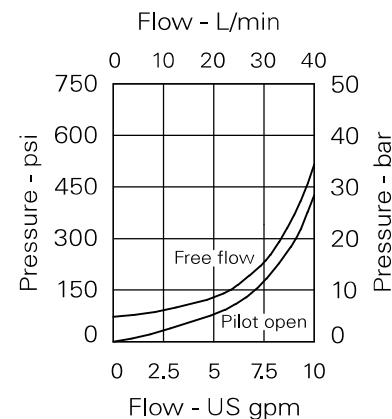

10:1 version

Where measurements are critical request certified drawings. We reserve the right to change specifications without notice.

# ISE30 - Overcenter valve

Pilot assisted relief with check  
30 L/min (8 USgpm) • 270 bar (4000 psi)

## Model code

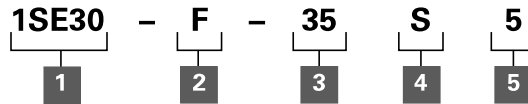

### 1 Function

1SE30

### 2 Adjustment means

F - Screw Adjustment

N - Fixed - State pressure setting required

For fixed versions add setting in 10 bar increments to end of part number. Subject to a ±10% tolerance.

### 3 Pressure range

Note: Code based on pressure in bar.h

20 - (All pilot ratios):  
70-225 bar.  
Std setting 100 bar

35 - (2.5:1 and 5:1): 70-350 bar.  
Std setting 210 bar  
(10:1): 90-350 bar.  
Std setting 210 bar

Std setting made at 4.8 L/min  
Other pressure ranges available on request

### 4 Seals

S - Nitrile (For use with most industrial hydraulic oils)

SV - Viton  
(For high temperature and most special fluid applications)

### 5 Pilot ratio

2 - 2.5:1

5 - 5:1

10 - 10:1

## Dimensions

mm (inch)

### Cartridge only

Basic Code  
1SE30

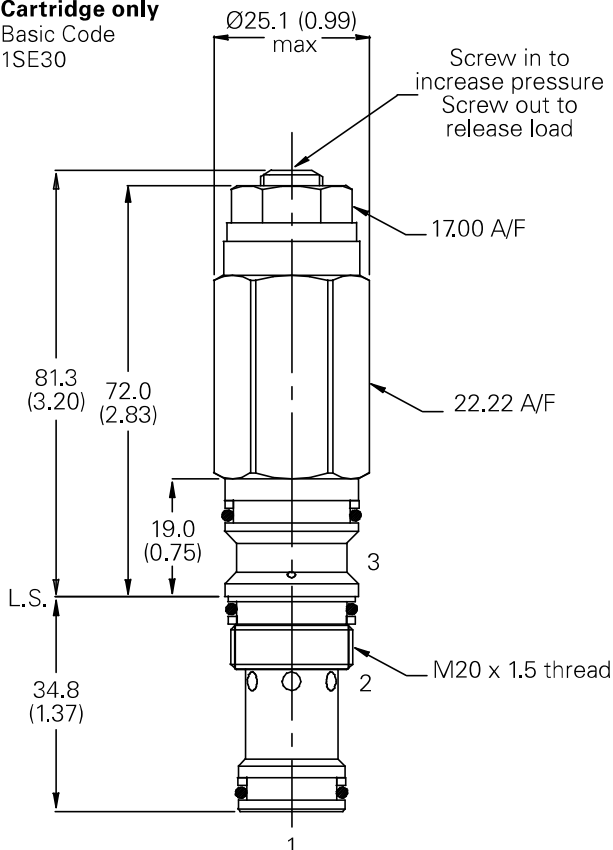

Note: Tightening torque of "F" adjuster locknut - 20 to 25 Nm.

### Cavity

Model A20090-  
T11A Form Drill  
TD-11A  
Form Reamer TD-11A

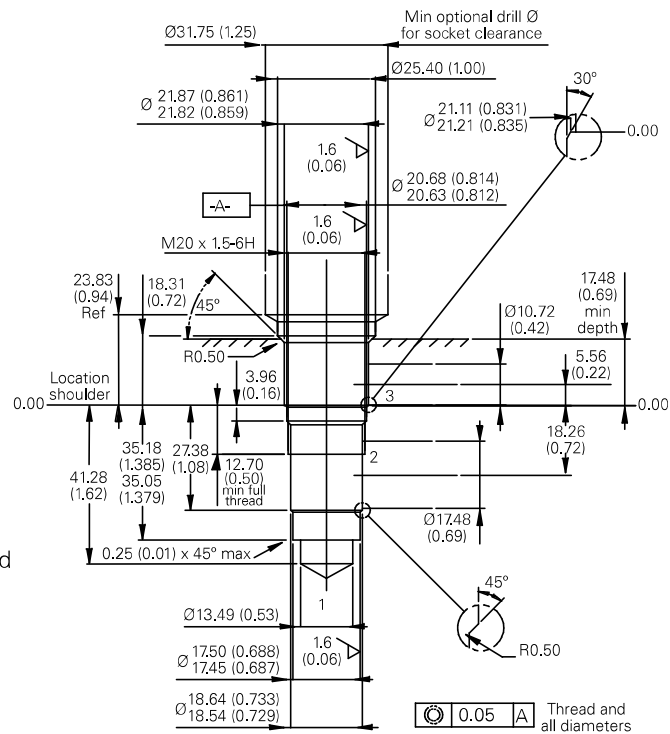

Where measurements are critical request certified drawings. We reserve the right to change specifications without notice.