

Mobile Valves

Proportional - Load Sensing
Model CLS100

350 bar
100 L/min

Up to 10 sections
Eaton Pro-FX™ Compliant

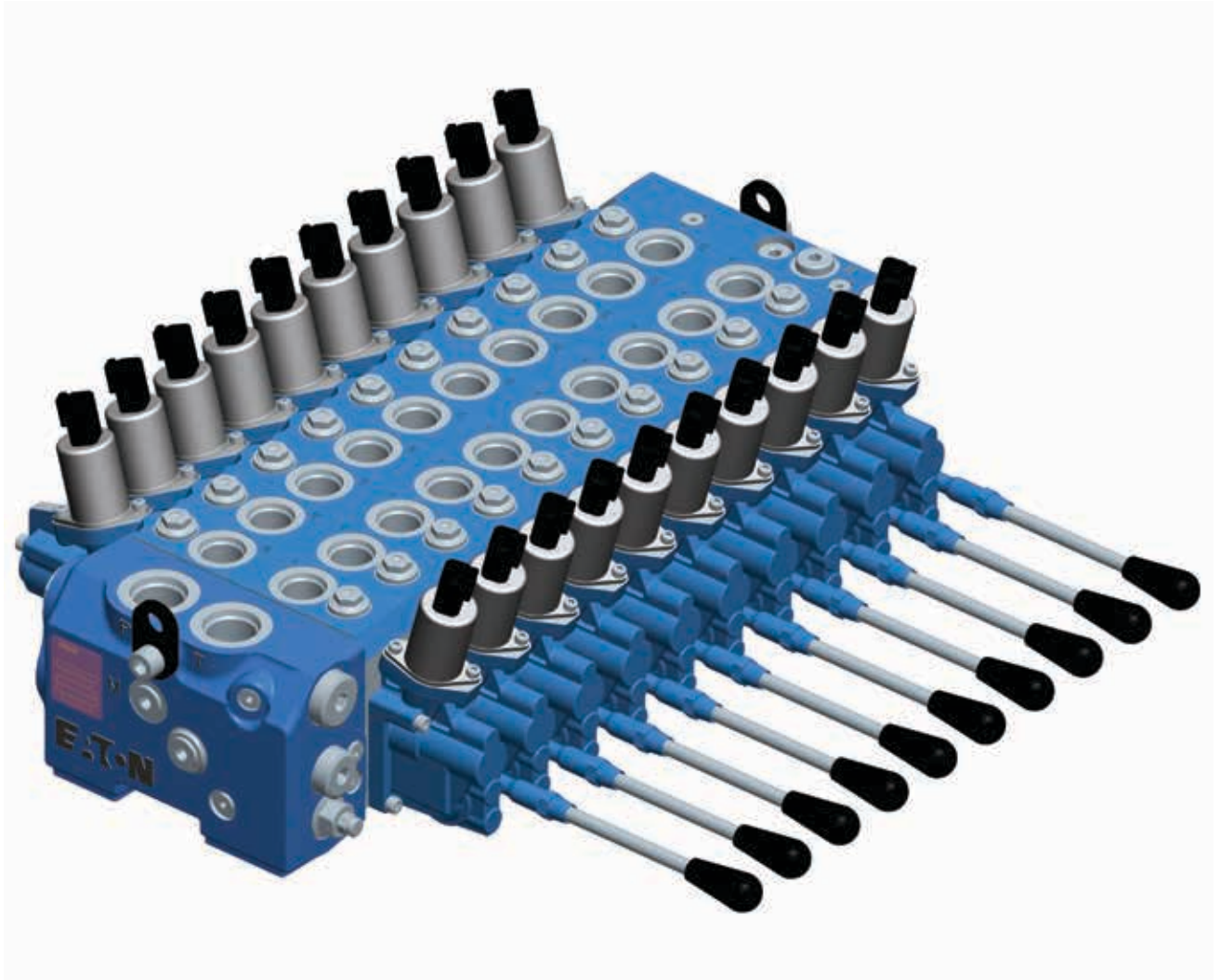

Powering Business Worldwide

Table of contents

Description	Page No.
Specifications and performance	4-5
Specifications and performance	4
Product overview	5
CLS load sense sectional mobile valve	6-14
Ordering example	6
Tie Rod Kits	7
CLS100 with manual actuation and enclosed lever box - Installation view	8
CLS100 with electrohydraulic actuation - Installation view	9
Typical curves	10-12
Typical work port auxiliary valve curves	13
Model code for valve bank inlet	14
CLS inlet – Configuration	15
CLS inlet – Relief valve options	16
CLS inlet – Dump valve options	17
Model code for sections	18
Features compatibility table	19
Valve section options – Compensation	20
Valve section options – Actuation for hydraulic control	21
Valve section options – Actuation for electrohydraulic control	22
Valve section options – Actuation for manual control	23
Valve section options – Spool type and spool return action	24
Valve Section options – Port A and Port B spool flows and coil type	25
Valve section options – Port A and Port B functions and settings	26
Valve section options – Load sense relief options and setting	27-28
Valve section options – Spool stroke limiter or position indicator and lever kit	29-30
Valve section options – Build type	31
Model code for valve bank end cover	32
CLS assembly – End covers	33-34
Mid-Inlet and transistion plates	35
Hydraulic fluid recommendations	36-37
Viscosity requirements	38

Eaton's CLS Load Sense Sectional Mobile Valve

Eaton's new CLS100 Load Sensing Sectional Mobile Valve is a pre and post compensated mobile valve with a highly versatile design. This modularity is demonstrated through the availability of valve banks with up to 10 sections, a number of spool types and actuation options, mid-inlets, custom inlet manifolds and transition plates. With this flexibility, you can design your valve to meet the requirements of your machine. Add in the ability to

install both pre and post compensated sections in the same valve bank; the CLS100 allows you to prioritize work functions to accelerate productivity, improve machine efficiency, and enhance the safety characteristics of the machine.

Improve your machine performance with the newest load sensing valve to market, the Eaton CLS100.

Features and benefits

- Load sense circuit design is a parallel circuit with closed center spools. Available with inlet options to support both fixed and variable displacement pumps
- Both pre and post comp sections available in same valve assembly
- Flexible design with up to 10 sections
- Electro-proportional spool control achieved through a PWM proportional pressure reducing solenoid valve controlling pilot pressure to spool ends to maintain spool position
- Optional manual, hydraulic and Electro-hydraulic controls with lever overrides
- Special features available for additional design flexibility:
 - Local load sense relief on pre and post compensated sections
 - Adjustable spool stroke limiting device
 - Parallel connection of multiple valve banks
 - Work port relief with anti cavitation
 - Available fourth position float

Typical applications

- Excavator – Multiple sizes
- Forestry
- Refuse trucks
- Forklift
- Agricultural machinery
- Truck mounted cranes
- Marine



Specifications and performance

CLS100 Load Sense Sectional Mobile Valve

Rated pressure	Inlet	350 bar (5076 psi)
	Work port	350 bar (5076 psi)
	Tank port	10 bar (145 psi)
	Pilot Drain Port (D1/D2)	5 bar (73 psi)
Rated inlet flow		150 lpm (39.6 gpm)
Rated workport flow - post compensated	100 lpm (26.4 gpm) @ 14 bar at differential pressure	
Fluid cleanliness and viscosity	See Hydraulic Fluid Recommendations Bulletin 03-401	
Ambient operating temperature range	-40°C / 60°C (-40°F / 140°F)	
Oil temperature operating range	-25°C / 80°C (-13°F / 176°F)	
Construction		Sectional
Work sections		1-10
Maximum leakage, cylinder workport to tank		11 cc per minute at 100 bar (1450 psi)
Port types	Inlet and Tank	SAE-12 or BSP G 3/4
	Work Ports A and B	SAE-10 or BSP G 1/2
	Inlet Pr Gauge port "M", LS port and Drain port	SAE-6 or BSP G 1/4
	Hydraulic Pilot	SAE-6 or BSP G 1/4
	Pneumatic Port	NPT 1/8" or BSP G 1/8
Work section options	Spools	Double acting (4 way) cylinder Double acting (4 way) cylinder with 4 th position float Bi-directional (4 way) motor, full open to tank in neutral
	Actuation	Hydraulic with top ports Hydraulic with top ports and lever override Hydraulic with end ports Hydraulic with end ports, lever override, and configured for EH pilot valve installation Electrohydraulic with lever override Electrohydraulic only Electrohydraulic with hydraulic ports and lever override Electrohydraulic with hydraulic ports Manual with enclosed lever box Manual with exposed spool connection Manual with pneumatic pilot, pneumatic ports downward Manual with pneumatic pilot, pneumatic top ports
Coil voltages		12 Volt DC 24 Volt DC
Coil connectors		Integral Deutsch DT04-2P Amp Jr. Timer connector 106462-1
Electrohydraulic interface		Eaton HFX programmable controllers and Pro-FX™ application software

CLS Load Sense Sectional Mobile Valve

Product Overview

The CLS100 valve line allows the customer the ability to combine pre and post compensated valve sections in the same valve bank. The pre compensated section acts as a priority flow sharing function by diverting flow to the pre compensated function first, then to the remaining sections in the bank.

The following schematics show an example of an all post-compensated system, and a system with an integrated pre compensated section.

Post compensated system

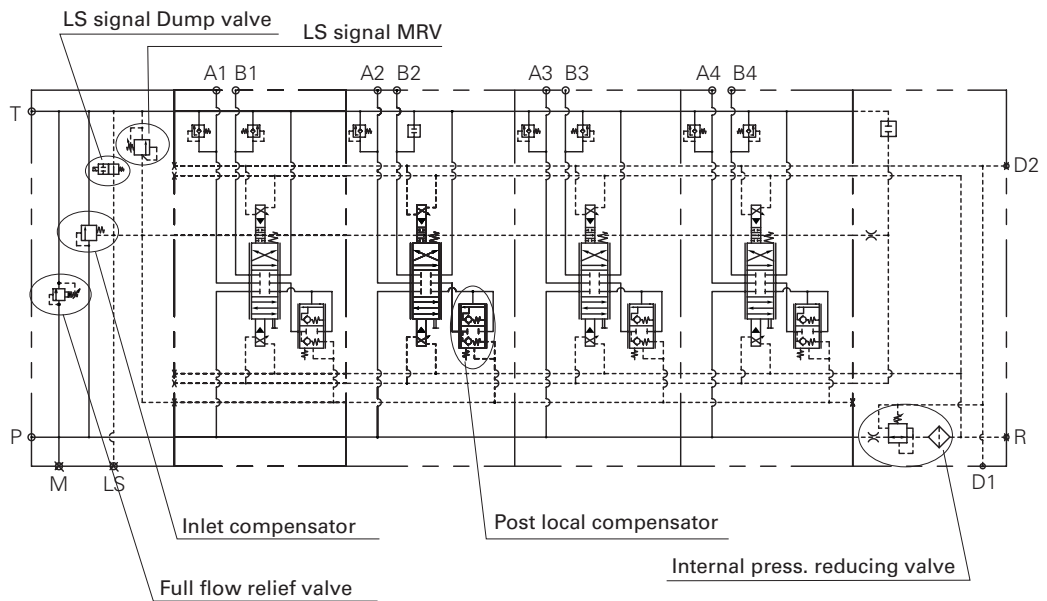

Pre compensated system

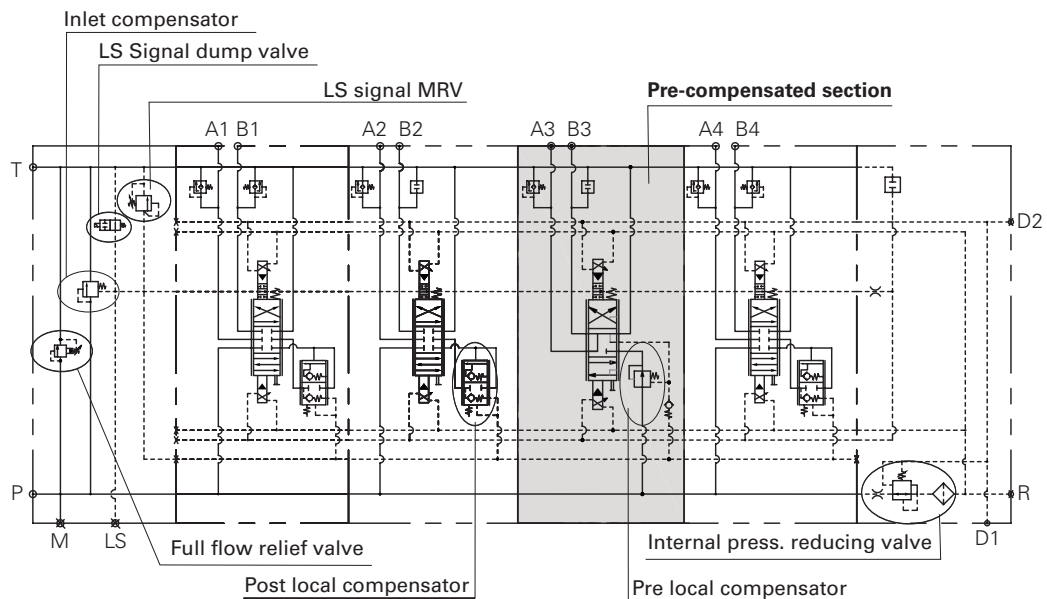

CLS Load Sense Sectional Mobile Valve

Ordering example

Valve bank order example

1. Inlet	CLS100LSL125000ZZ00B
2. Section 1	CLS101PESDA040040CP000P000Z000ZBL00B
3. Section 2	CLS101PESDA040040CP000P000Z000ZBL00B
4. Section 3	CLS101PESDA040040CP000P000Z000ZBL00B
5. End Cover	CLS102GS00B
6. CLS100/3 Tie Rod Kit	6042571-003
7. Paint	00

Note: Repeat section model code for additional sections.

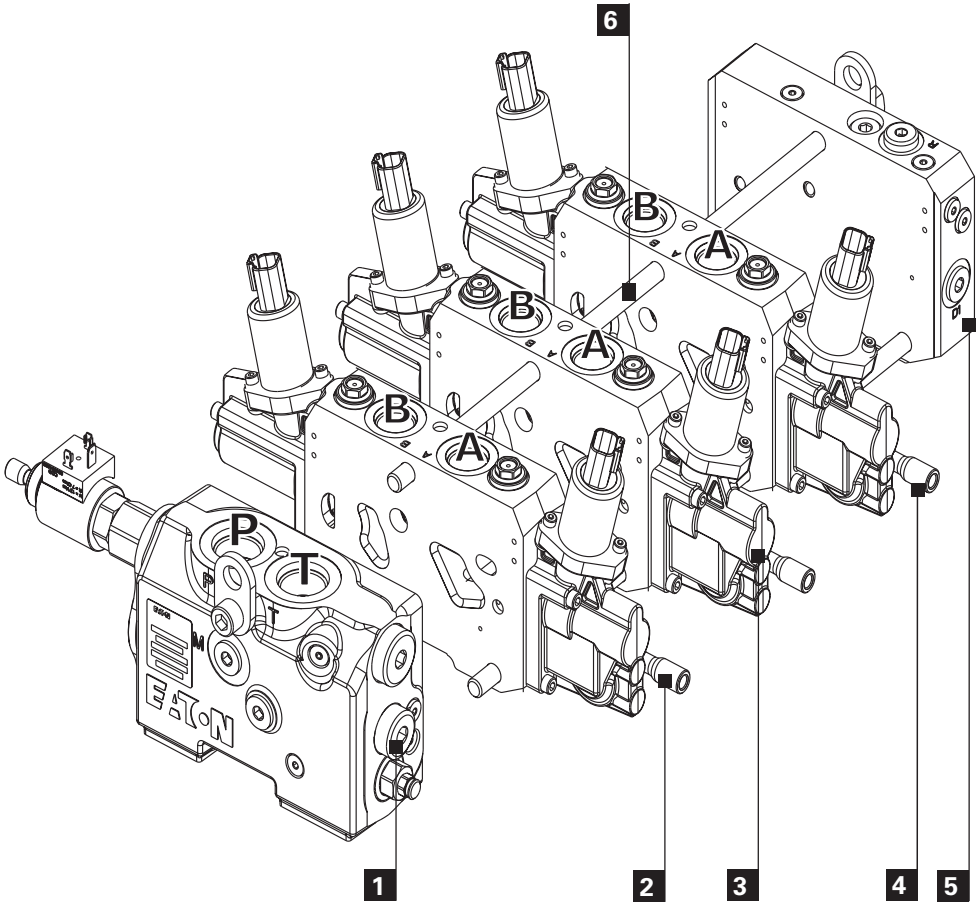

CLS Load Sense Sectional Mobile Valve

Tie Rod Kits

Tie rod kits are required to complete a valve bank assembly. Tie rod length depends on the number of sections in the bank. Each tie rod kit includes three (3) tie Rods, three (3) nuts and three (3) washers.

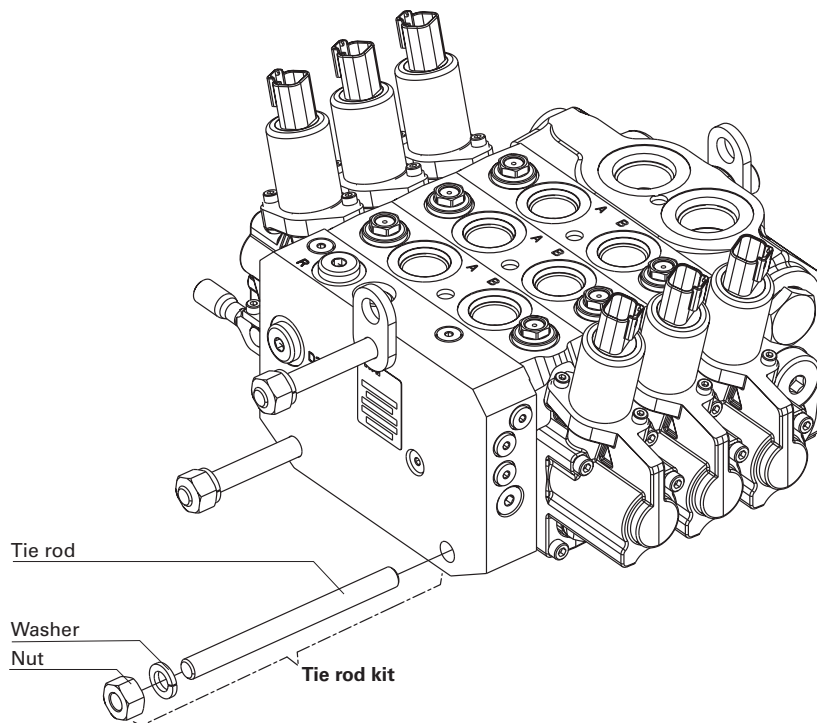

Tie Rod Kit	Desc.	EH End plate version	Length (mm)	Hyd End plate version	Length (mm)
CLS100/1	1 Sect.	6042571-001	102	6042572-001	96
CLS100/2	2 Sect.	6042571-002	140	6042572-002	134
CLS100/3	3 Sect.	6042571-003	178	6042572-003	172
CLS100/4	4 Sect.	6042571-004	217	6042572-004	211
CLS100/5	5 Sect.	6042571-005	255	6042572-005	249
CLS100/6	6 Sect.	6042571-006	293	6042572-006	287
CLS100/7	7 Sect.	6042571-007	331	6042572-007	325
CLS100/8	8 Sect.	6042571-008	370	6042572-008	364
CLS100/9	9 Sect.	6042571-009	408	6042572-009	402
CLS100/10	10 Sect.	6042571-010	445	6042572-010	439

Tightening : 40 Nm

Code	Paint
00	None
0B	Black
BD	Yellow
0C	Red
CD	Eaton Blue (Primer)
OK	Green

**All paint is finish coat with exception to Eaton Blue, which is a primer coat.

CLS Load Sense Sectional Mobile Valve

CLS100 with manual actuation and enclosed lever box

Units: mm

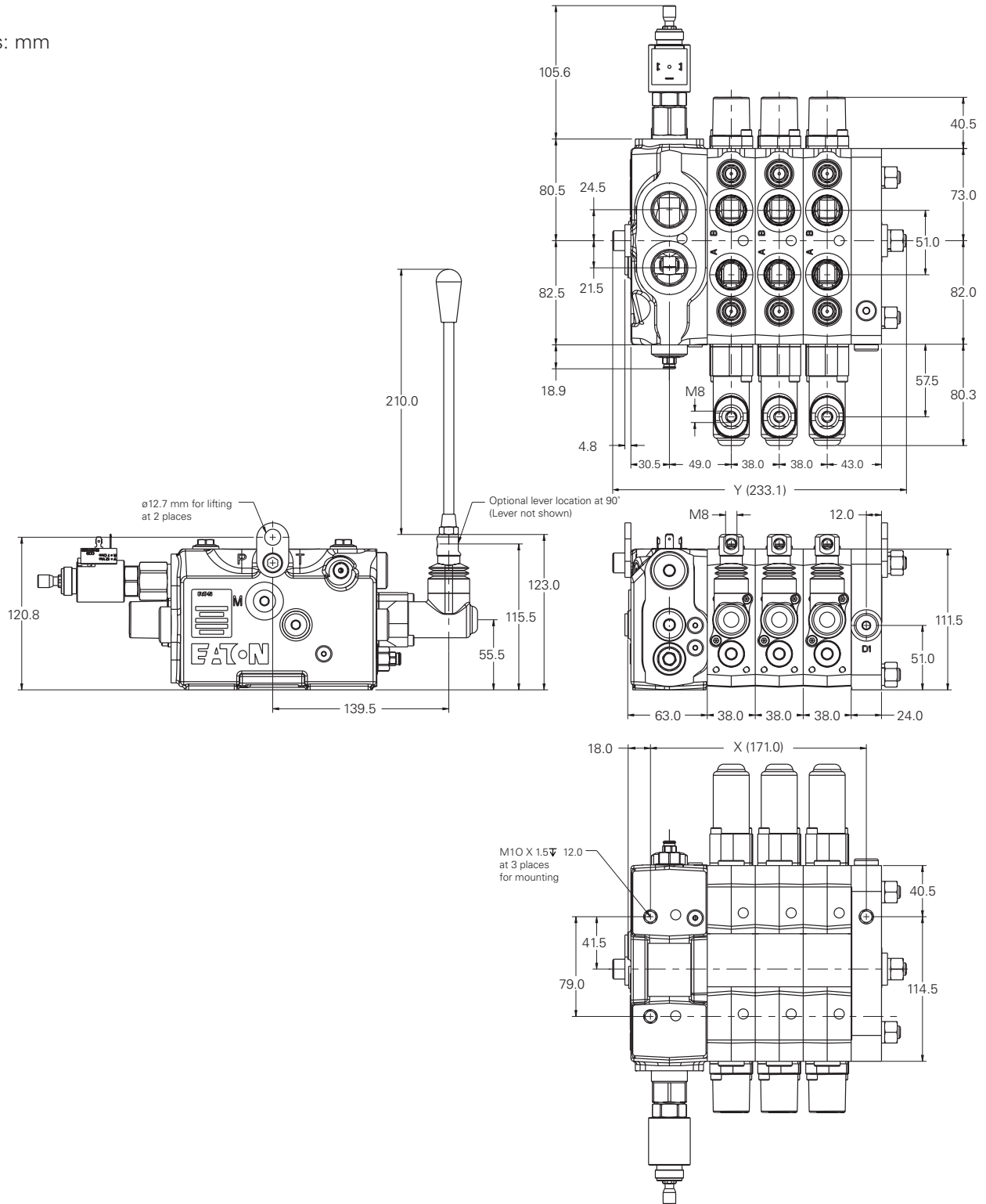

Dimension	Number of sections									
	/1	/2	/3	/4	/5	/6	/7	/8	/9	/10
X (mm)	95	133	171	209	247	285	323	361	399	437
Y (mm) Max	157	195	233	272	310	348	386	425	463	500
Weights (kg)	14,5	18,5	22,5	26,5	30,5	34,5	38,5	42,5	46,6	50,5

CLS Load Sense Sectional Mobile Valve

CLS100 with electrohydraulic actuation

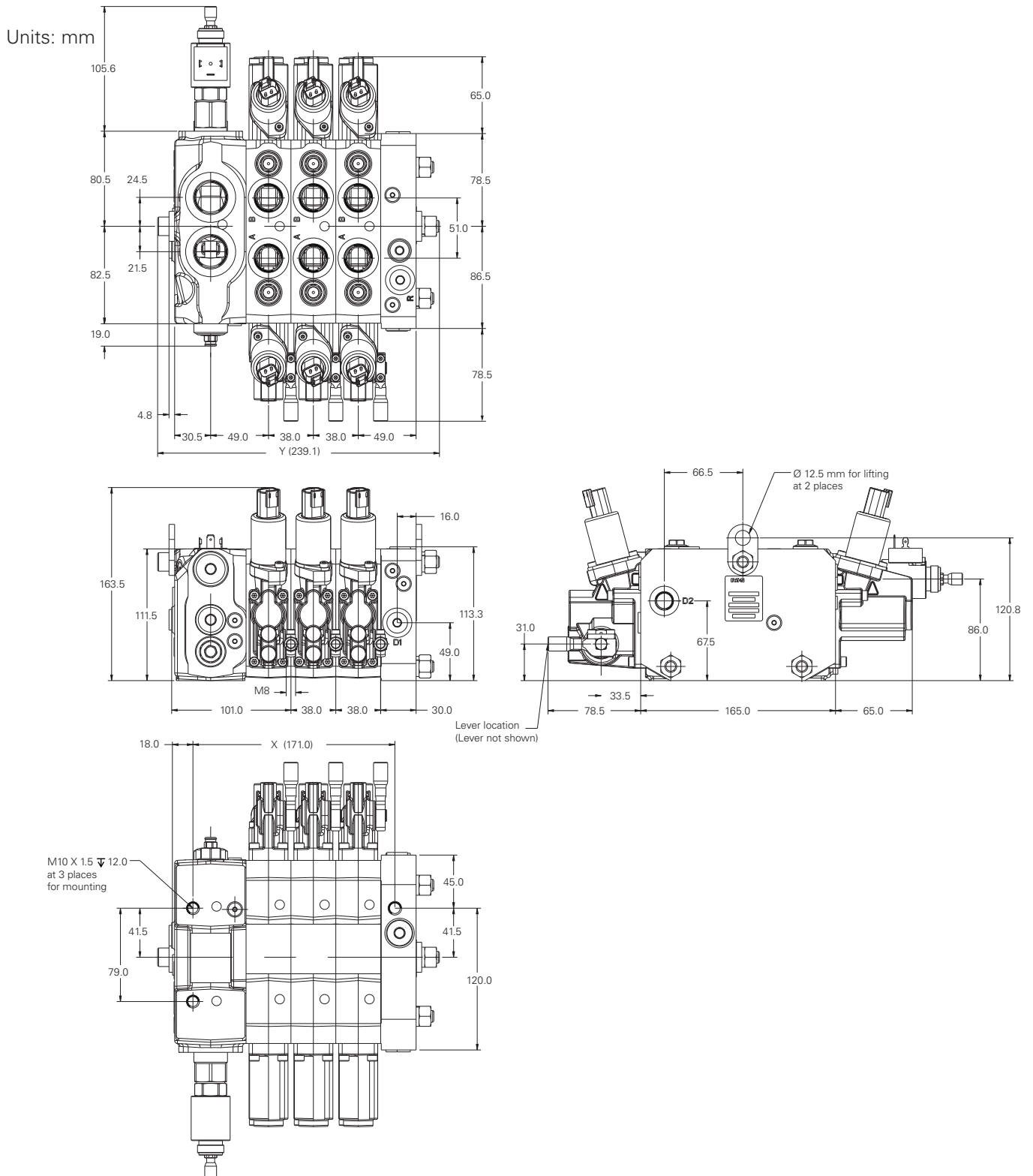

Dimension	Number of sections									
	/1	/2	/3	/4	/5	/6	/7	/8	/9	/10
X (mm)	95	133	171	209	247	285	323	361	399	437
Y (mm) Max	163	201	239	278	316	354	392	431	469	506
Weights (kg)	15	19.5	24.0	28.5	33.0	37.5	42.0	46.5	51.0	55.5

CLS Load Sense Sectional Mobile Valve

Typical curves

Inlet compensator pressure drop (P-T)

Fixed displacement system: pressure drop across the inlet compensator as function of pump flow

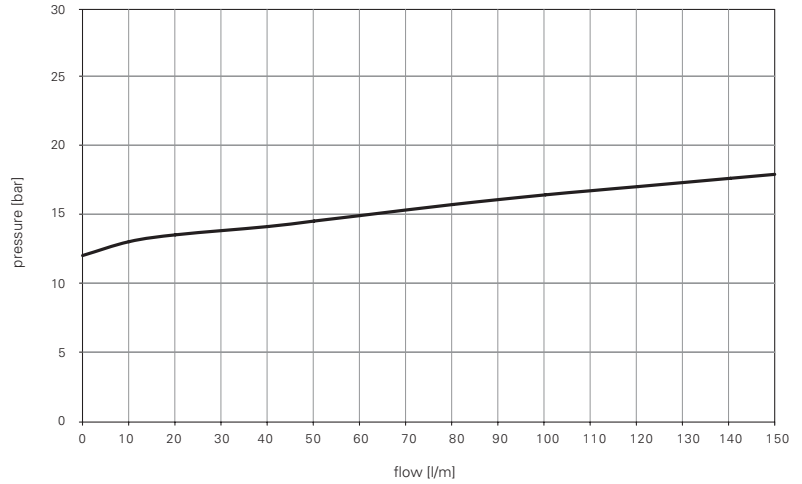

LS signal pressure relief valve

Fixed displacement system: LS Signal pressure relief valve characteristic

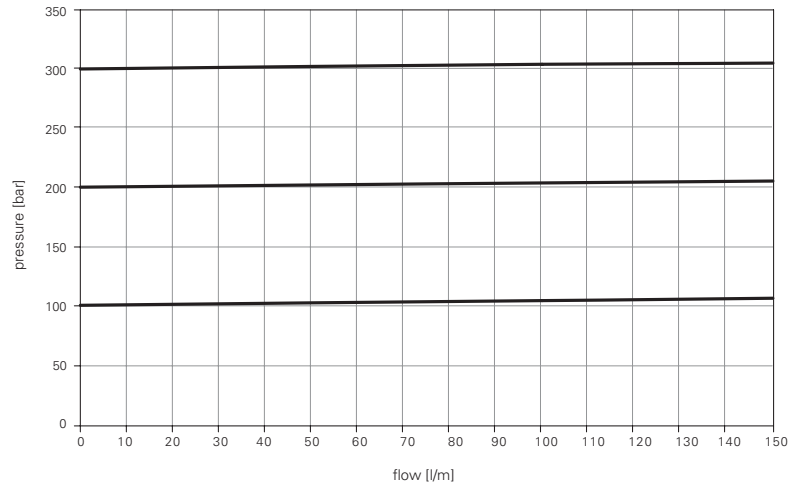

Full flow dump valve

Fixed displacement systems: pressure drop across open electric dump valve as function of pump flow

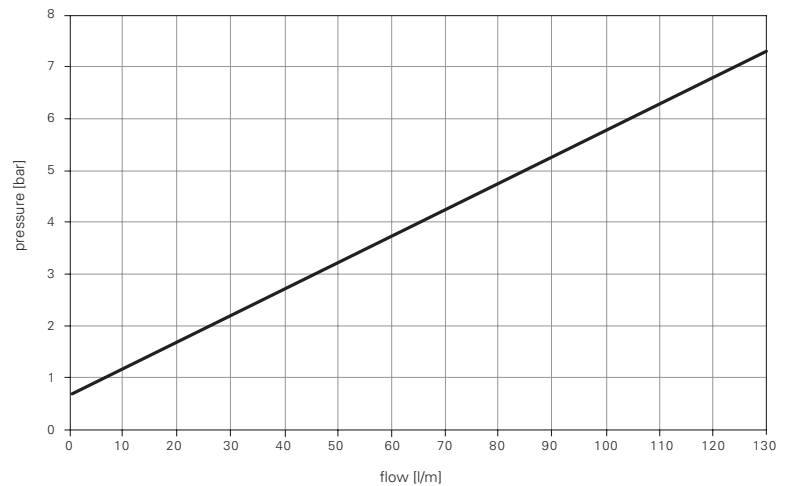

CLS Load Sense Sectional Mobile Valve

Typical curves

Post compensated spool flow characteristic

Flow on ports A and B as function of spool stroke, pilot pressure, control current.

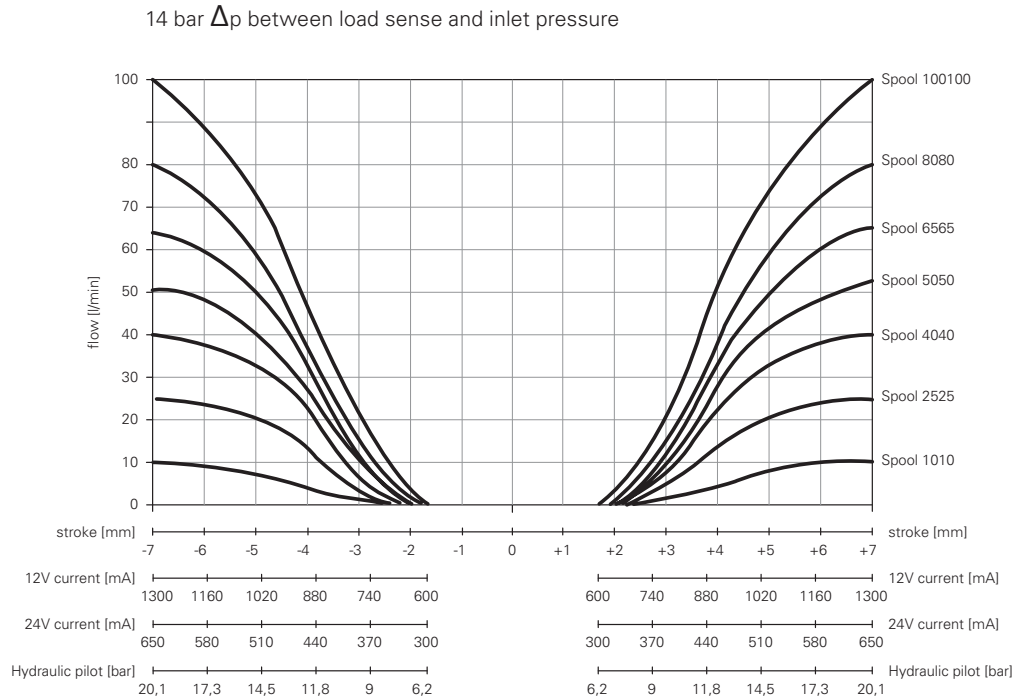

Spool flow versus delta pressure

With post comp, maximum flow is a function of the delta P created by the variable displacement pump

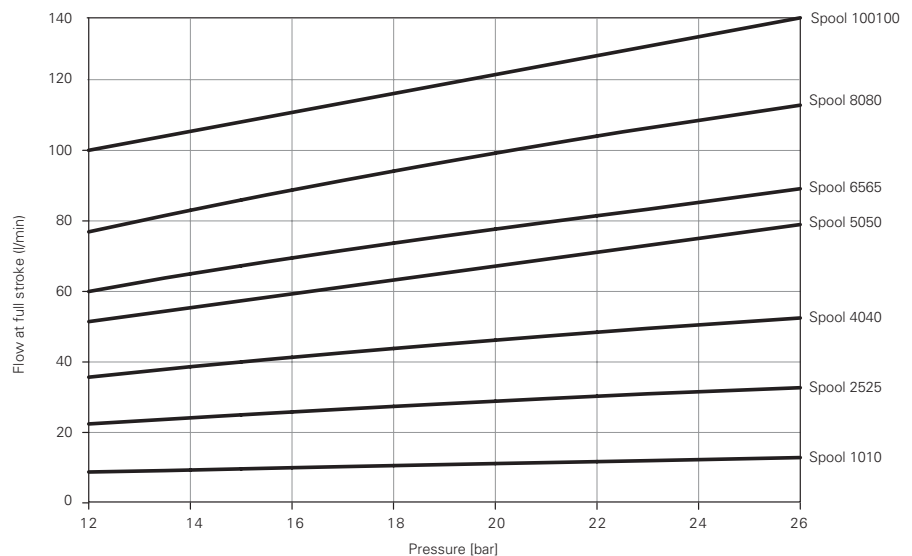

CLS Load Sense Sectional Mobile Valve

Typical curves

Pre compensated spool flow characteristic

Flow on ports A and B as function of spool stroke, pilot pressure, control current.

14 bar Δp between load sense and inlet pressure

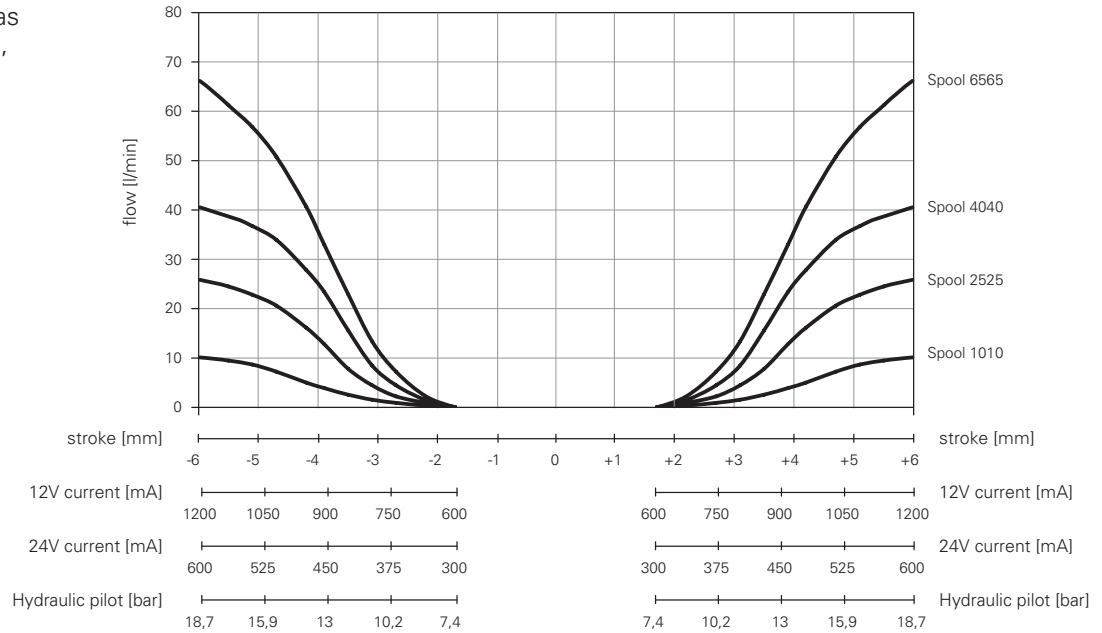

Post compensated four position float spool characteristic

Flow and float position as function of spool stroke, pilot pressure, control current

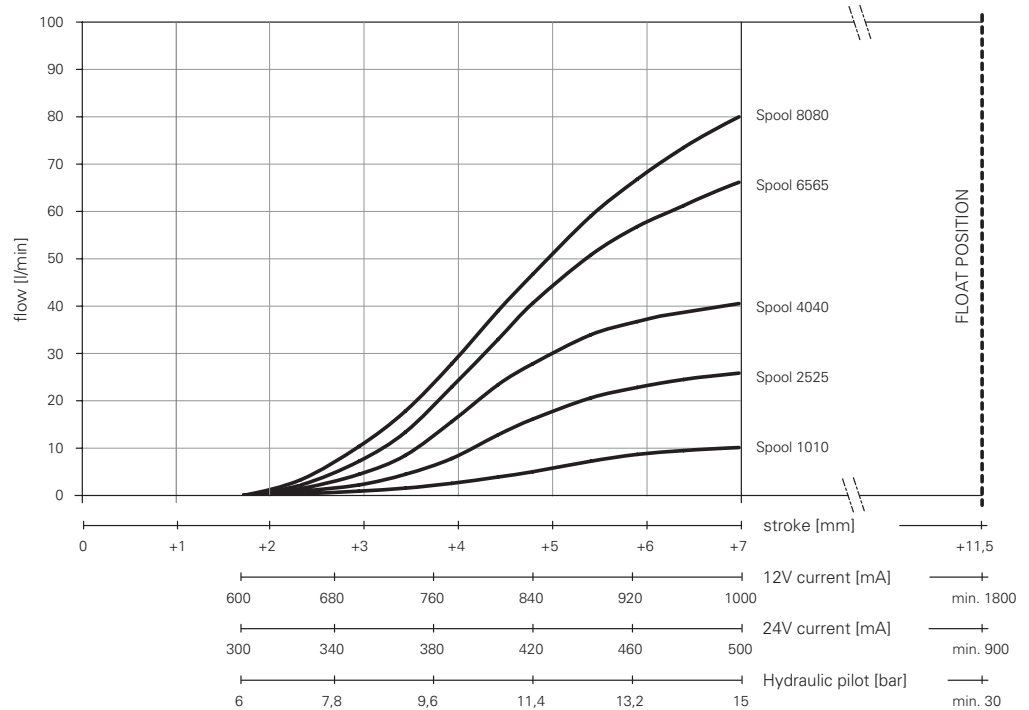

CLS Load Sense Sectional Mobile Valve

Typical work port auxiliary valve curves

Work Port Relief Valve (relief mode)

Pressure characteristic as function of flow

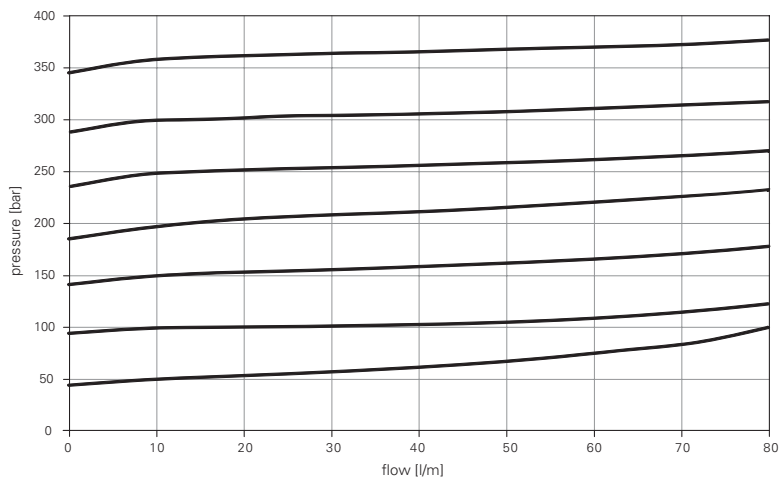

Work Port Relief Valve (anti-cav mode)

Opening and pressure characteristic as function of flow

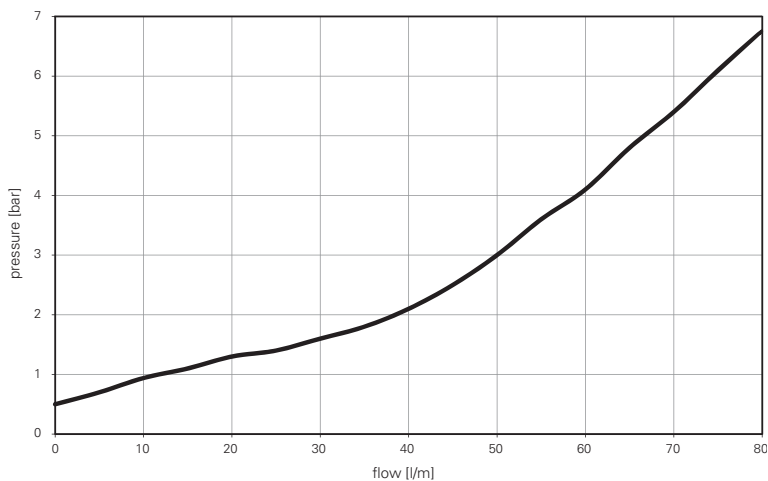

Model code for valve bank inlet

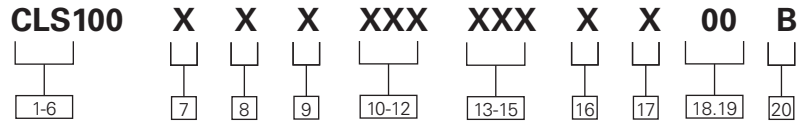

1-6 Product Series

CLS100 – Load Sense Sectional Mobile Valve: Standard Valve Bank Inlet

7 Inlet Type

L – Load Sensing (Variable disp. pumps)
U – Unload for Open Center (fixed disp. pumps)

8 Inlet Ports

B – BSP (G3/4 P&T, G1/4 LS&M)
S – SAE (-12 P&T, -6 LS&M)

9 Inlet Reliefs

D – LS & Full Flow Reliefs
L – LS Relief Only
R – Full flow relief only*
Z – No Reliefs

10-12 Load Sense Relief Setting

XXX – 3 Digit Load Sense Relief Setting in 5 Bar Increments, Code 000 if none
Note: 50-350 bar LS Relief setting should be minimum 40 Bar lesser than Full flow relief setting. Anything above 350 bar is rated for intermittent operation. Consult engineering for duty cycle acceptance above 350 bar

* R - Full flow relief only option is not recommended. Inlet LS relief is recommended, which limits system pressure and gives better efficiency.

13-15 Full Flow Relief Setting

XXX – 3 Digit Full Flow Relief Setting in 5 Bar Increments, Code 000 if none
Note: 90-350 bar
 "Settings above 350 bar should only be used with approval of duty cycle"

16 Inlet Dump Valve

F – Full Flow Dump Valve
L – LS Dump Valve
Z – No Dump Valve

17 Inlet Coil

A – 12V Coil with DIN Connector
B – 24V Coil with DIN Connector
C – 12V Coil Deutsch Connector
D – 24V Coil Deutsch Connector
E – 12V Coil AmpJr Connector
F – 24V Coil AmpJr Connector
Z – No Coil

18-19 Special Features

00 No special features

20 Design Level

B – Latest design

Notes:

1. Cannot have full flow relief valve and full flow dump valve in same inlet. Full flow relief valve and full flow dump valve cavities are different, so these are not interchangeable.
2. Transition plates and mid-inlets are available on request.

CLS inlet – Configuration

Model code positions 7 & 8

L - Load sensing

Closed center inlet section for variable displacement pumps

The inlet section with L configuration enables control valve usage with variable displacement pumps. With this configuration the presence of LS relief valve is suitable to adjust the system maximum pressure. LS electric dump valve can also be added as safety device. An additional full flow relief valve can be added to protect the system from pump regulator failures.

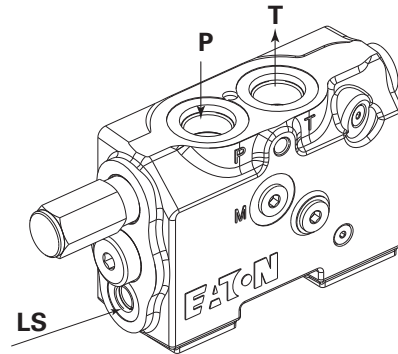

U - Unload for open center

Open center inlet section for fixed displacement pumps

The inlet section with U configuration enables control valve usage with fixed displacement pumps. With this configuration the presence of LS relief valve is suitable to adjust the system maximum pressure. Full flow electric dump valve can also be added as safety device.

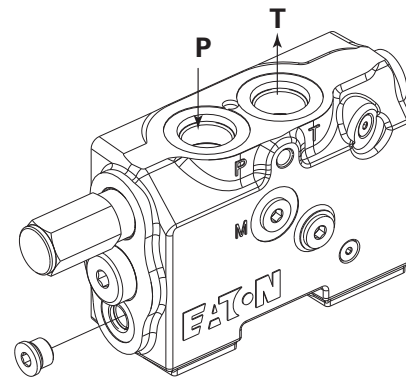

CLS inlet – Relief valve options

Model code position 9

D - LS & full flow reliefs

Note: This combination requires that the Full Flow Relief be set at least 40 bar higher than the LS Relief.

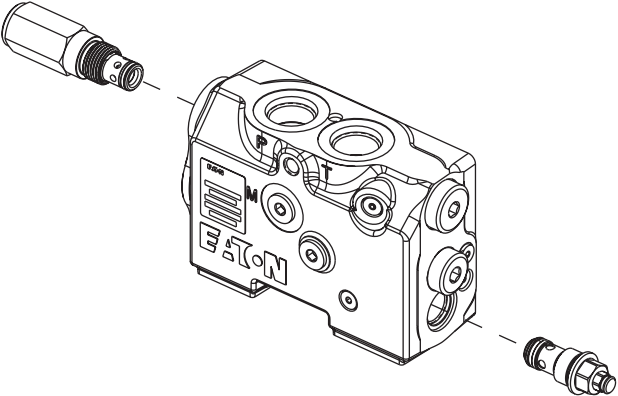

L - LS relief only

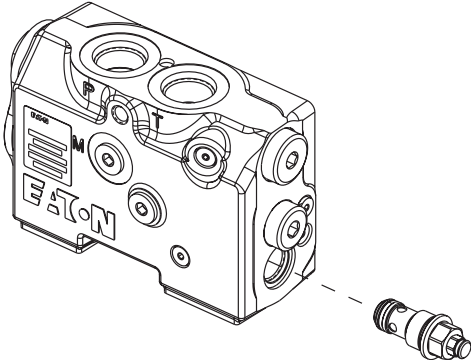

R- Full flow relief only

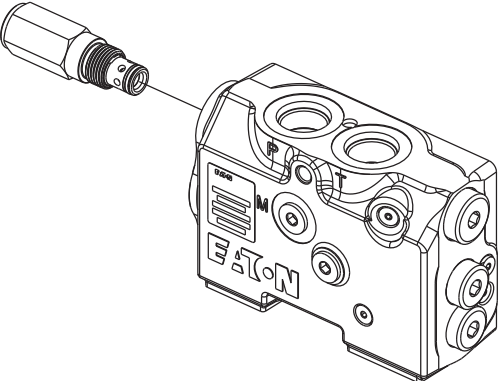

Z - No reliefs

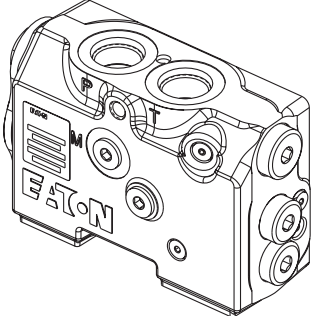

CLS inlet – Dump valve options

Model code positions 16 & 17

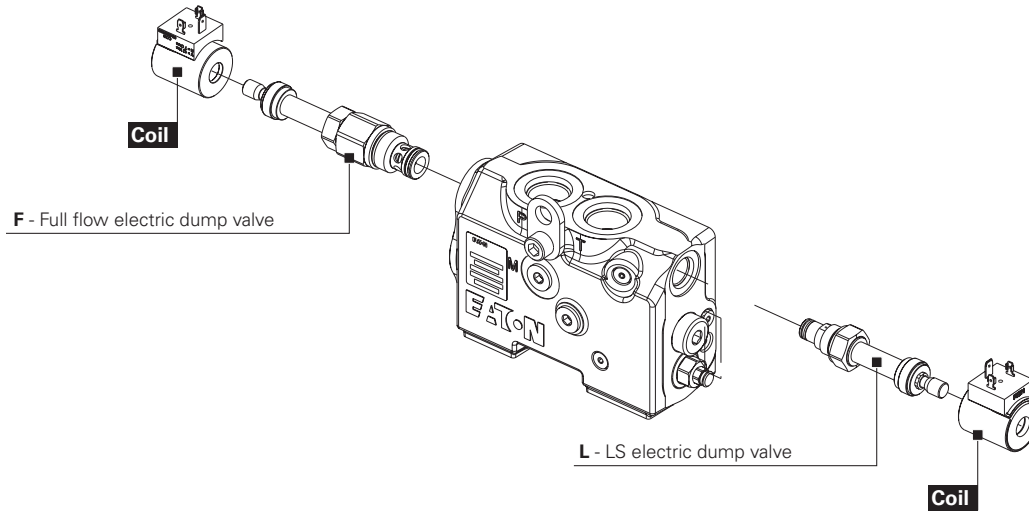

F - Full flow dump valve

L - LS Electric dump valve

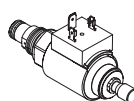
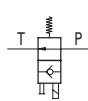
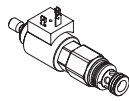
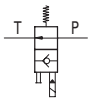

Coil and Connectors specifications for inlet section

Option	Connector types (Deutsch/Amp Jr)	Ingress Rating	Coil Resistance R20 (Ω)	Connector Material	Coil Body	Duty Cycle	Coil Insulation	Power
A	A - 12V Coil with DIN Connector	IP 65	7	Nylon	Zinc plated steel	ED 100%	Class H coil - IEC 85 Standard	20.5 W
B	B - 24V Coil with DIN Connector	IP 65	28					
C	C - 12V Coil with Detuch Connector	IP 67	7					
D	D - 24V Coil with Detuch Connector	IP 67	28					
E	E - 12V Coil with AmpJr Connector	IP 65	7					
F	F - 24V Coil with AmpJr Connector	IP 65	28					

Model code for sections

The following 36 digit coding system has been developed to identify preferred feature options for the CLS100 Load Sense Sectional Mobile Valve series. Use this code to

specify a valve with the desired features. All 36-digits of the code must be present to release a new product number for ordering.

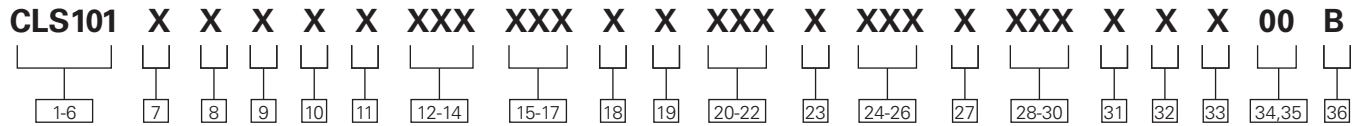

1-6 Product Series

CLS101 – Load Sense Sectional Mobile Valves

7 Compensation

P – Post-compensated
R – Post-compensated with Local Flow Limiter ***
L – Pre-compensated

8 Actuation

A – Hydraulic with Top Ports
B – Hydraulic with Top Ports and Lever Override
C – Hydraulic with End Ports
D – Hydraulic with End Ports, Lever Override, and Configured for EH Pilot Valve Installation
E – Electrohydraulic with Lever Override
F – Electrohydraulic Only
G – Electrohydraulic with Hydraulic Ports and Lever Override
H – Electrohydraulic with Hydraulic Ports
L – Manual with Enclosed Lever Box
M – Manual with Exposed Spool Connection
N – Pneumatic with port downward with enclosed lever box
P – Pneumatic with top port with enclosed lever box
R – Pneumatic with port downward with exposed spool connection
S – Pneumatic with top port with exposed spool connection

9 Port Type

B – G1/2 BSP (G1/4 Pilot if Hyd., G1/8 if Pneumatic)
S – SAE, -10 (SAE -6 Pilot if Hyd., 1/8 NPTF if Pneumatic)

10 Spool Type

D – Double Acting (4 Way) Cylinder
F – Double Acting (4 Way) Cylinder with 4th Position Float #
H – Bi-Directional (4 Way) Motor, Full Open to Tank in Neutral

11 Spool Action

A – Spring Centered to Neutral
B – Detent “In” and “Out” *
C – Fourth Position Float #
E – Fourth Position Float Detent* #
F – Friction - Hold in Position*

12-14 Port A Spool Flow

005 – 5 l/m
010 – 10 l/m
015 – 15 l/m
025 – 25 l/m
035 – 35 l/m
040 – 40 l/m
050 – 50 l/m
065 – 65 l/m
080 – 80 l/m
100 – 100 l/m

15-17 Port B Spool Flow

005 – 5 l/m
010 – 10 l/m
015 – 15 l/m
025 – 25 l/m
035 – 35 l/m
040 – 40 l/m
050 – 50 l/m
065 – 65 l/m
080 – 80 l/m
100 – 100 l/m

18 Coil Type

C – 12V coil Deutsch connector

D – 24V coil Deutsch connector

E – 12V coil AmpJr connector

F – 24V coil AmpJr connector

Z – No coil

19 Port A Option Function

A – Anti-Cav
R – Relief/Anti-Cav
P – Plugged - Work port Cavities Machined and Plugged
Z – None - Option Port No Machining

20-22 Port A Option Setting

XXX – 040-350 (3 digit, fixed setting in 10 bar increments), relief valve pressure setting, port A

23 Port B Option Function

A – Anti-Cav
R – Relief/Anti-Cav
P – Plugged - Work port Cavities Machined and Plugged
Z – None - Option Port No Machining

24-26 Port B Option Setting

XXX – 040-350 (3 digit, fixed setting in 10 bar increments), relief valve pressure setting, port B

27 Local LS Relief Option

P – Post Comp - Section Load Sense Relief (Applies to Both A & B Ports)** ##
L – Pre Comp - Section Load Sense Relief (Applies to Both A & B Ports)***
R – Post Comp - SAE -4 or G1/8 Port for Remote Load Sense Relief (Applies to Both A & B Ports)**

Y – Pre Comp - SAE -4 or G1/8 Port for Remote Load Sense Relief (Applies to Both A & B Ports)***
Z – No LS Relief

28-30 LS Relief Setting

XXX – 3 Digit Section LS Relief Setting in 5 bar increments from 50-350 bar (000 if not Present or if Using Remote LS Relief)

31 Spool Stroke Limiter or Position Indicator

A – Electrohydraulic Section w/Spool Stroke Limiter
B – Hydraulic Section w/Spool Stroke Limiter
P – Electrohydraulic Spool Position Indicator
Z – None

32 Lever Kits

A – 135mm (5.5”) Lever Kit
B – 210mm (8.5”) Lever Kit
Z – None

33 Build Type

R – Right Hand (Std for Pre Comp)
L – Left Hand (Std for Post Comp)

34,35 Special Features

00 – No special features

36 Design Level

B – Latest Design

Note: Pre/Post compensation spools offer varying flows, please reference page 25 on applicable spool flow

* Available with Manual Actuation only

** Available with LH build only

*** Available with RH build only

Available with RH build and post comp option only

Local LS relief option not available for EH float actuation

Features compatibility table

Compatibility chart for spool action options with compensation type

Combination			Spool Action (Model code position-11)												
			A – Spring Centered to Neutral		B – Detent “In” and “Out”		C – Fourth Position Float				E – Fourth Position Float Detent (Manual)		F – Friction hold in Position		
			RH Build	LH Build	RH Build	LH Build	Hydraulic		Electrohydraulic		RH Build	LH Build	RH Build	LH Build	
							RH Build	LH Build	RH Build	LH Build					
Compensation (Model code position-7)	Post comp	With Local LS relief	•	•	•	•	•				•		•		
		W/O Local LS relief	•	•	•	•	•		•		•		•	•	
	Post comp with local flow limiter	With Local LS relief	•	•	•	•	•				•				
		W/O Local LS relief	•	•	•	•	•		•		•			•	
	Pre comp	With Local LS relief	•	•											•
		W/O Local LS relief	•	•										•	•

Compatibility chart for hydraulic and electrohydraulic actuations having manual override option

Combination			Compensation (Model code position-7)				
			Post comp		Post Comp with local flow limiter		Pre comp
			With Local LS Relief	With Local LS Relief	W/O Local LS Relief	With Local LS Relief	
Actuation (Model code position-8)	B – Hydraulic with top ports and lever override	RH Build			•	•	
		LH Build	•				
	D - Hydraulic with end ports, lever override and configured for EH pilot valve installation	RH Build			•	•	
		LH Build	•				
	E - Electrohydraulic with lever override	RH Build			•	•	
		LH Build	•				
	F – Electrohydraulic only	RH Build			•	•	
		LH Build	•				
	G - Electrohydraulic with hydraulic ports and lever override	RH Build			•	•	
		LH Build	•				
	H - Electrohydraulic with hydraulic ports	RH Build			•	•	
		LH Build	•				
	N/P/R/S-Pneumatic actuation	RH Build	•	•	•		
		LH Build			•		

Valve section options – Compensation

Model code position 7

The CLS family offers an unique additional feature: the ability to mix pre and post compensated technologies, to improve the control capabilities and manage flows

with different priorities. The following schematics show an example for the two systems.

P - Post compensated (flow sharing)

Available with or without auxiliary valve cavities

Note: Shown with auxiliary valves

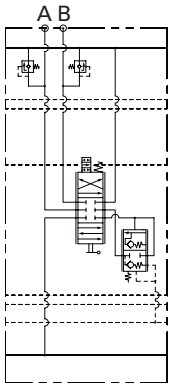

Mechanical lever actuation

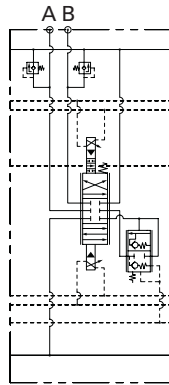

Electrohydraulic actuation

L - Pre compensated

Available with or without auxiliary valve cavities

Note: Shown with auxiliary valves

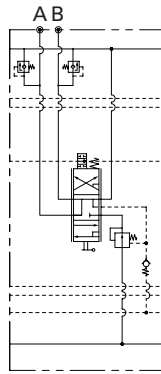

Mechanical lever actuation

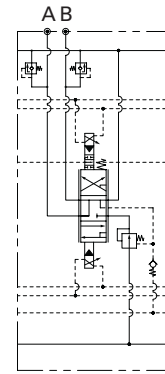

Electrohydraulic actuation

R - Post compensated (flow sharing) with local flow limiter

Available with or without auxiliary valve cavities

Note: Shown with auxiliary valves

Available with RH build only.

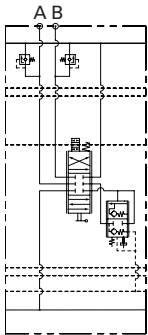

Mechanical lever actuation

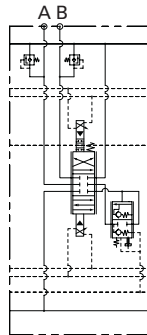

Electrohydraulic actuation

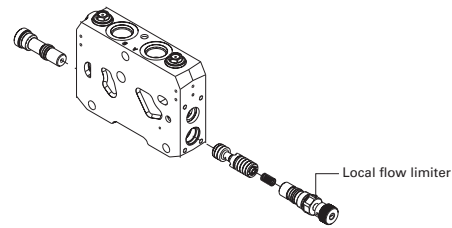

Valve section options – Actuation for hydraulic control

Dimensions and configurations for model code position 8

Units: mm

A - Hydraulic with top ports

Hydraulic actuation (pilot ports on the top)

(Only with manual and hydraulic section body)

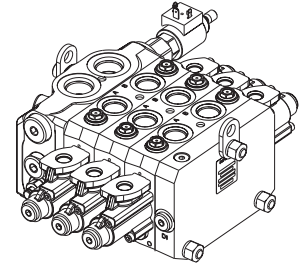
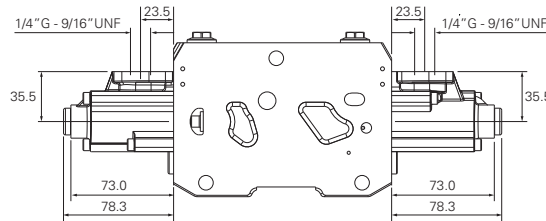

B - Hydraulic ports and lever override

Lever actuation and hydraulic actuation

(Only with EH type body)

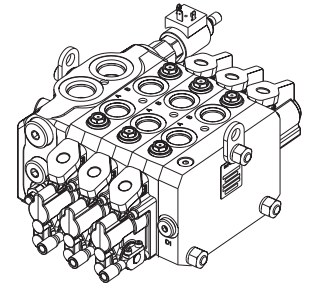
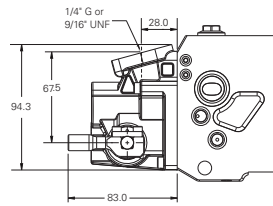

C - Hydraulic with end ports

Hydraulic actuation (pilot ports on the sides)

(Only with manual and hydraulic section body)

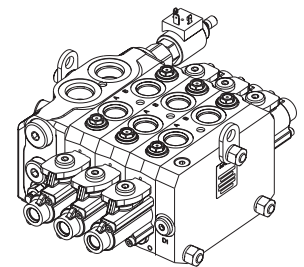
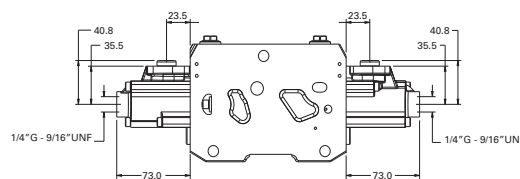

D - Hydraulic with End ports, lever override, and configured for EH pilot valve installation

Lever and hydraulic actuation with electrohydraulic arrangement

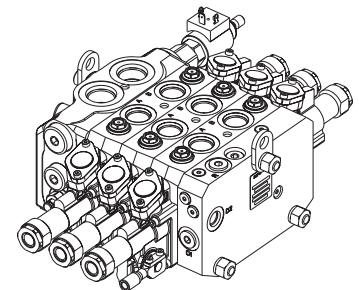
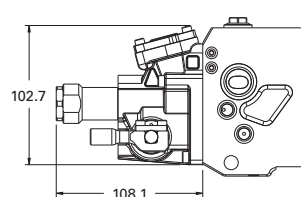

Valve section options – Actuation for electrohydraulic control

Dimensions and configurations for model code position 8

Units: mm

E - Electrohydraulic with lever override

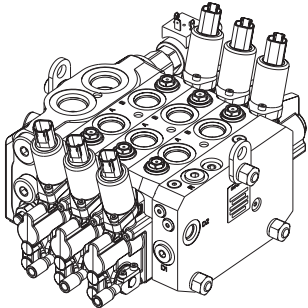
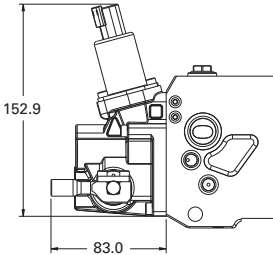

F - Electrohydraulic only

Without lever

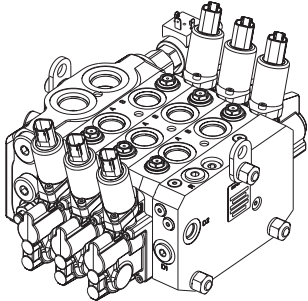
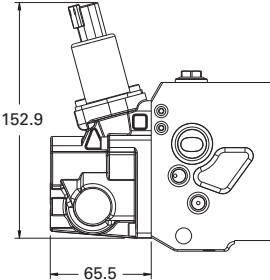

G - Electrohydraulic with hydraulic ports and lever override*

Lever, hydraulic, and electrohydraulic actuation

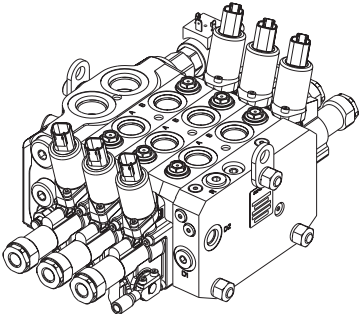
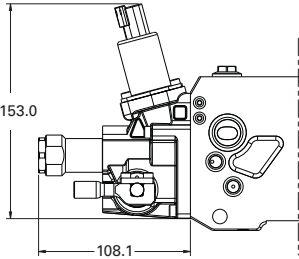

H - Electrohydraulic with hydraulic ports*

Without lever, hydraulic, and electrohydraulic actuation

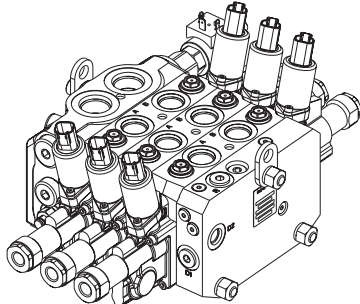
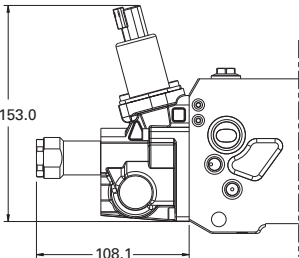

Note: * Plastic shipping plugs fitted on hydraulic ports.

Valve section options – Actuation for manual control

Dimensions and configurations for model code position 8

Units: mm

L - Manual with enclosed lever box

Lever actuation
(Only with manual and hydraulic section body)

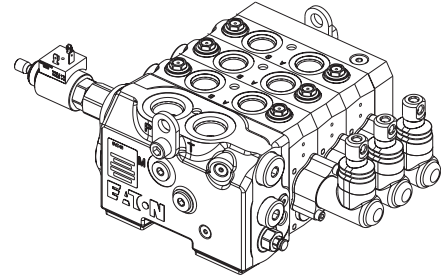
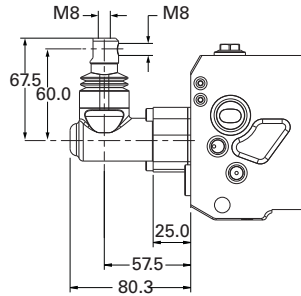

M - Manual with exposed spool connection

Without lever actuation
(Only with manual and hydraulic section body)

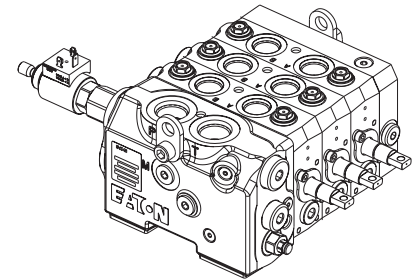
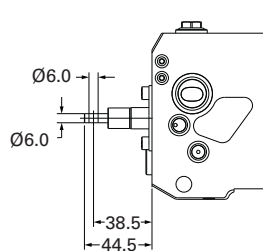

N - Pneumatic with ports downward with enclosed lever box

P - Pneumatic with top ports with enclosed lever box

R - Pneumatic with ports downward with exposed spool connection

S - Pneumatic with top ports with exposed spool connection

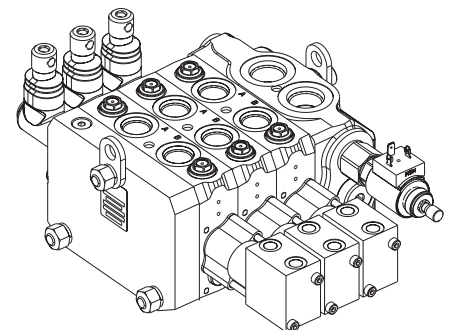
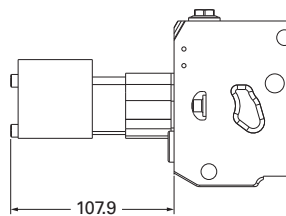

Note: P type depicted in graphic

Note: Only available on post compensated sections

Valve section options – Spool type

Model code position 10

**D -
Double acting (4 way)
cylinder**

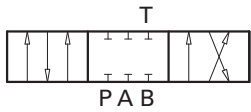

**F -
Double acting (4 way)
cylinder with 4th position
float***

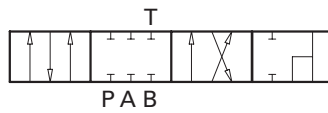

**H -
Bi-directional (4 way)
motor, full open to tank
in neutral**

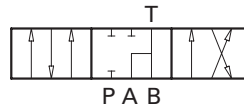

Note: Spool F requires additional valve body machining and special 4th position detent selection

* Available with RH build and post comp option only

Valve Section Options – Port A and Port B spool flows

Model code positions 12-14 (port A) and
Model code positions 15-17 (port B)

Post compensated section

Spool Type	Flow Rates (l/min)									
	005	010	015	025	035	040	050	065	080	100
D	•	•	•	•	•	•	•	•	•	•
H	•	•	•	•	•		•	•	•	•
F		•			•			•	•	

Pre compensated section

Spool Type	Flow Rates (l/min)			
	015	025	040	065
D	•	•	•	•
H	•	•	•	•

Note: Rated flows are defined for 14 bar Δp .

Listed flows are for symmetrical spools; for questions regarding asymmetric spools please contact your sales representative

Valve section options – Coil Voltage and Connector

Model code position 18

Coil and connector specifications

Option	Supply voltage (VDC)	Connector	Ingress Rating	Coil resistance R_{20} (Ω)	Feeding Reducing Pressure	Prop. current control (mA)	On-Off current control (mA)	PWM Suggested frequency (Hz)
C	12	Deutsch DT4	IP 67	4.7	40 bar	600-1300	2500	70-90
D	24	Deutsch DT4	IP 67	20.8		300-650	1150	
E	12	Amp Jr	IP 65	4.7		600-1300	2500	
F	24	Amp Jr	IP 65	20.8		300-650	1150	

Valve section options – Port A and Port B functions and settings

Model code positions 20-26

A - anti-cav

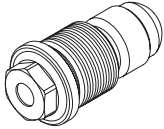

R - relief/anti-cav

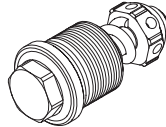

Note: Factory setting 40-350 bar
in 10 bar increments

P - Plugged - work port valve cavities machined and plugged

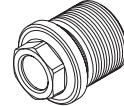

Valve section options – Load sense relief setting

Model code position 27-30

P - post compensated - section load sense relief (applies to both A & B ports)

Schematic for
manual control

Schematic for
electrohydraulic control

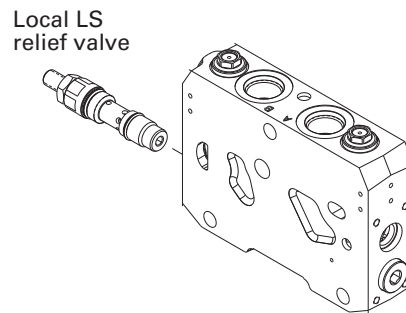
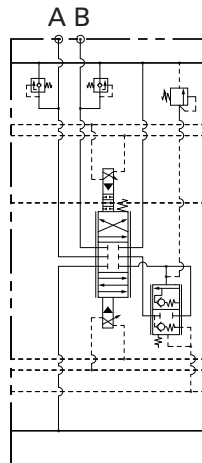
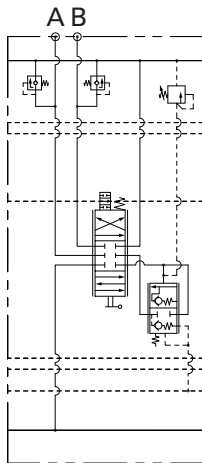

Note: Post Comp Section Load Sense relief prohibits flow share if multiple sections containing local load sense reliefs are operated simultaneously. Available with LH build only

L - pre compensated - section load sense relief (applies to both A & B ports)

Schematic for
manual control

Schematic for
electrohydraulic control

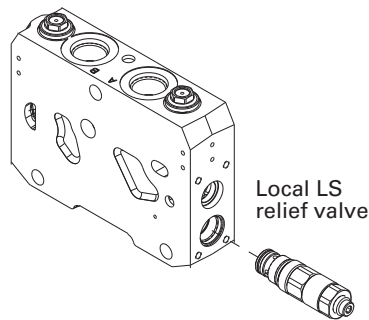
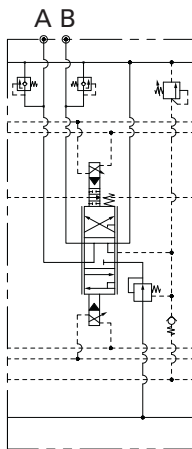
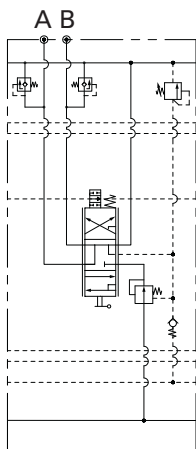

Note: Pre comp load sense relief range is 50-350 bar.
Available with RH build only.

Valve section options – Load sense relief setting

Model code position 27-30

R - post comp - port for remote load sense relief (applies to both A & B ports)

Schematic for manual control

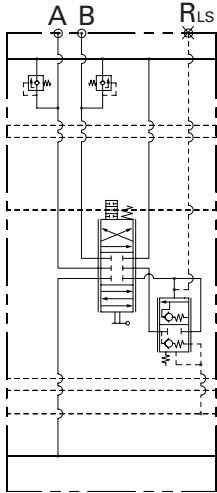

Schematic for electrohydraulic control

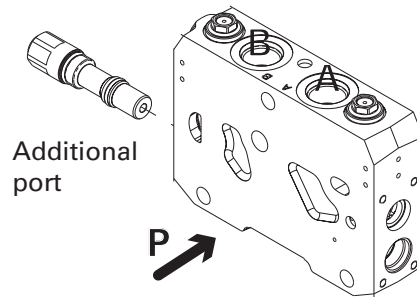
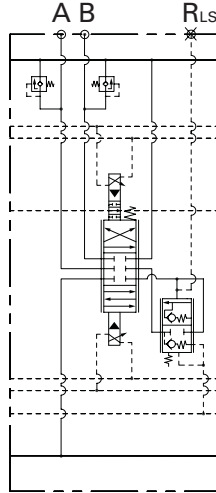

Note: Available with LH build only.

Requires left valve bank inlet selection

Y - pre comp - port for remote load sense relief (applies to both A & B ports)

Schematic for manual control

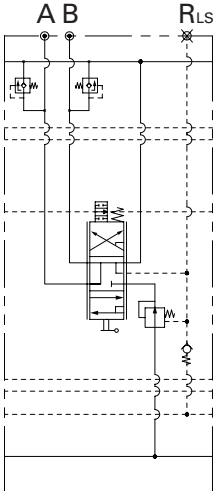

Schematic for electrohydraulic control

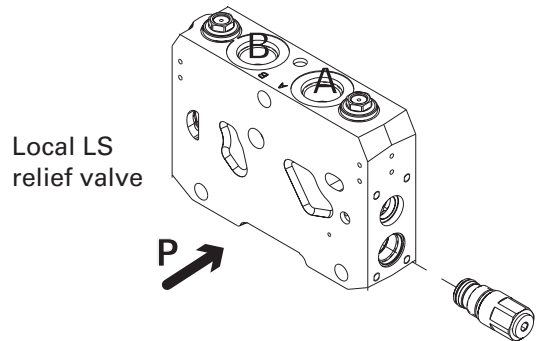
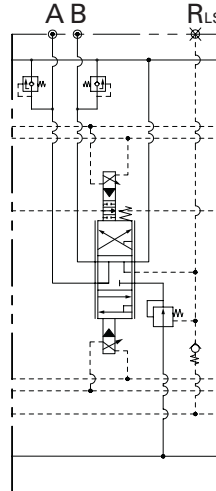

Note: Available with RH build only.

The Post Comp Section Load Sense Relief works properly if the section is actuated alone or is operating at the highest pressure

Valve section options – Spool stroke limiter or position indicator

Dimensions and configurations for model code position 31

Spool position indication is achieved using a Hall effect sensor device used in conjunction with spool position transducer kits available for CLS100. After the final assembly of the valve a computer assisted calibration procedure is performed that compensates for mechanical inaccuracies and uncertainties allowing to attain high accuracy and linearity in spool position detection. Spool position is output as an analog voltage signal in the 0.5 - 4.5V range. The unit works in 12V and 24V environments and is protected against load-dump and other major electrical faults. Fault signalling is carried out through the output signal.

Technical specifications	
Electrical	
Operating voltage	6 - 30 Vdc
Max current consumption	20.5 mA
Output	
Output voltage spanning	0.5 - 4.5 Vdc
Quiescent voltage	2.5 Vdc
Output current	-1 - +1 mA
Minimum output load resistance	4.5 kOhm
Overall accuracy	± 2.5%
Resolution	12 bit
Fault signalling levels	4.8V < Vout < 0.2 Vdc
Protections	short circuit protection, reverse, battery protection, thermal shutdown, overvoltage, undervoltage, load-dump
EM Immunity	> 60 Vdc/m
Mechanical, Environmental	
Operating temperature	-40 / +85 °C
Ingress Protection Rating	IP 65
Dimensions	28 x 18 x 23 mm (L x W x H)
Connections	
I/O	DIN 43650-C male
PIN 1	Vout
PIN 2	Vcc
PIN 3	OV
PIN 4	Chassis (connected to valve body)
Applied standards	
Immunity for industrial environments	EN 61000-6-2
Emission standard for residential commercial and light-industrial environments	EN 61000-6-3
EMC - Agricultural and forestry machines	EN 14982
EMC - Earth-moving machinery	ISO 13766

Valve section options – Spool stroke limiter or position indicator

Dimensions and configurations for
model code position 31

Units: mm

A - Electrohydraulic section with spool stroke limiter

With lever override

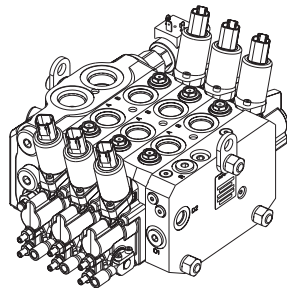
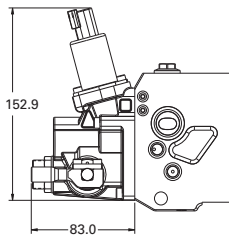

Without lever override

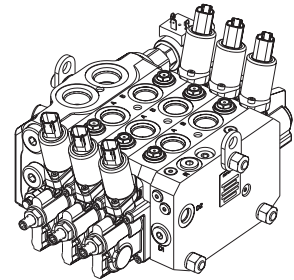
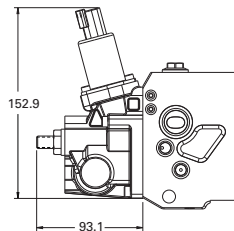

B - Hydraulic section with spool stroke limiter

Hydraulic actuation with
stroke limiter

Note: Not shown in the graphic but also
available with manual override

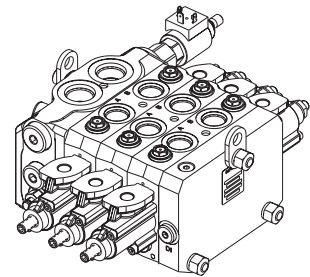
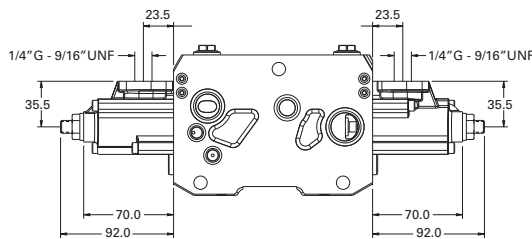

P - Electro-hydraulic with spool position indicator

Note: Not shown in the graphic but also
available with manual override

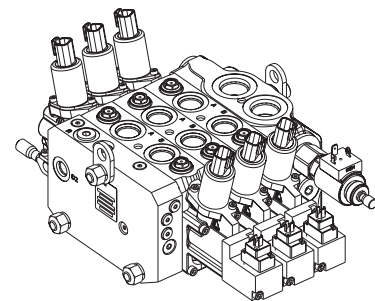
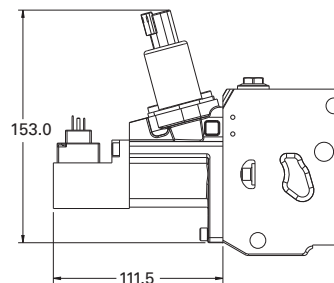

Valve section options - Lever Kits

Model Code Position 32

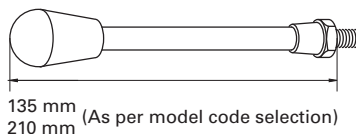

A - 135 Lever kit

Lever with knob - 135mm (5.5")

B - 210 Lever kit

Lever with knob - 210mm (8.5")

Section Build Type

Model code position 33

R - Right hand build (Standard build for Pre comp section)

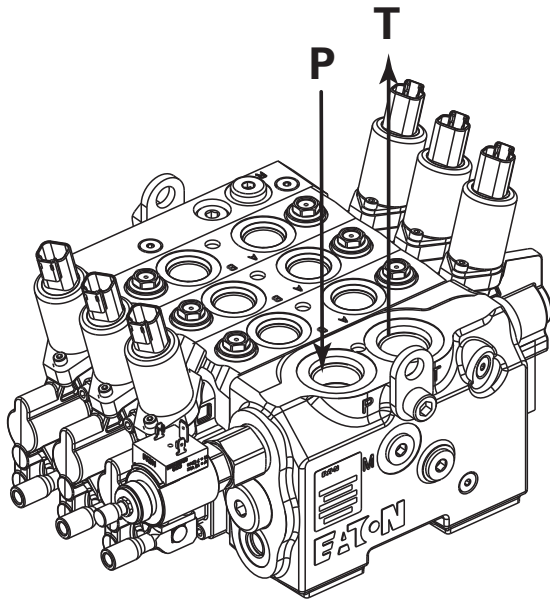

L - Left hand build (Standard build for Post comp section)

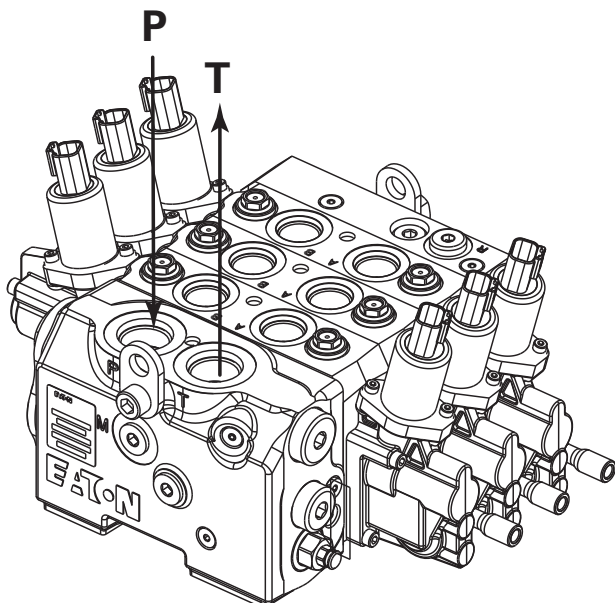

Model code for valve bank end cover

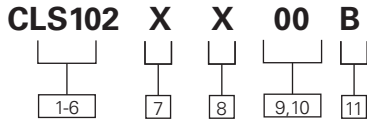

1-6 Product series

CLS102 Load sense sectional mobile valves

7 End cover

- F** Electrohydraulic with external end drain#
- G** Electrohydraulic with external side drain#
- H** Hydraulic or manual with internal drain
- K** Hydraulic or manual with external drain#
- N** Electrohydraulic with internal drain*

8 End cover ports

- B** BSP (G1/4 pilot drain)
- S** SAE (-6 pilot drain)

11 Design level

- B** Latest design

9,10 Special features

- 00** No special features

There are two types of End Covers:

Manual and Hydraulic actuation version

To be used when no electrohydraulic controls are present in the valve bank. This cover is simply collecting the LS signal drain that can be connected to tank internally or externally.

Electrohydraulic version

To be used when at least one section in the valve bank has electrohydraulic actuation. This cover is collecting LS signal and electrohydraulic pilot control drain and is providing electrohydraulic actuation by way of a pressure reducing valve.

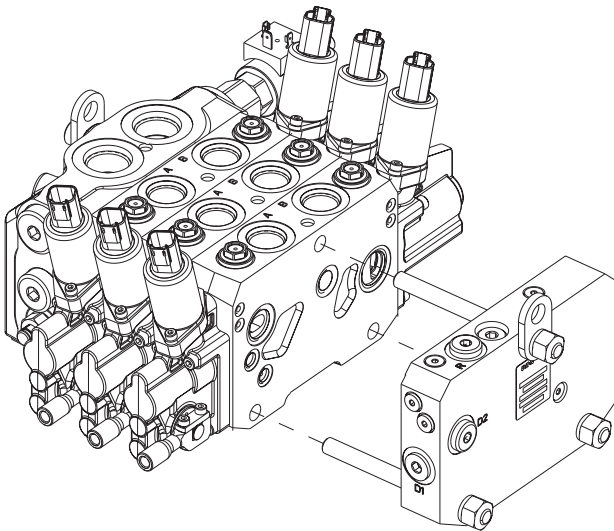

Important:

With electrohydraulic actuation, plumb external drain directly to reservoir, not to tank or tank line. Drain pressure shall remain below 5 BAR

Side port (D1) or End port (D2) should be used as drain port.

* When EH with internal drain option is used, care should be taken to ensure pressure in inlet "T" port should not exceed 5 bar

CLS assembly – End covers

Schematics and configurations for model code position 7

F - Electrohydraulic with external end drain

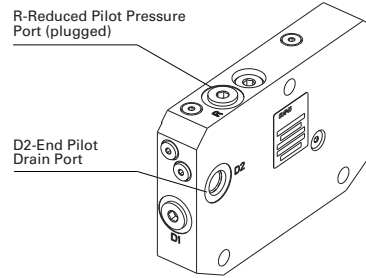
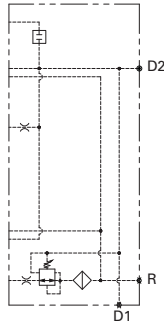

G - Electrohydraulic with external side drain

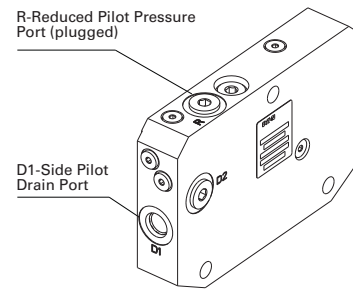
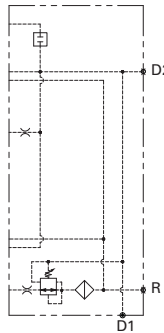

H - Hydraulic or manual with internal drain

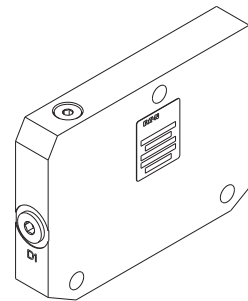
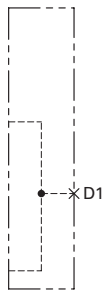

CLS assembly – End covers

Schematics and configurations for model code position 7

**K -
Hydraulic or manual
with external drain**

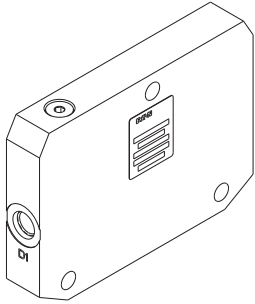
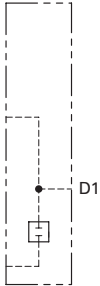

**N -
Electrohydraulic with
internal drain**

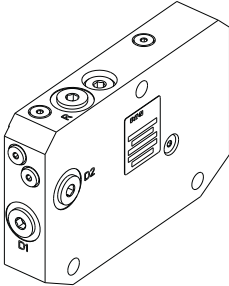
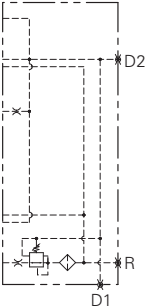

Mid-Inlet and transition plates

The CLS mobile valve family offers standard mid-inlet and transition plates for options of split or combined flow. With the ability to combine CLS models, you can simplify the valve assembly for minimal space utilization and lower cost for machines that require a range of various flows. Eaton offers the following standard mid-inlet and transition plates for the CLS mobile valve family.

Frame size	Type.	P/N#
CLS250-180	INTERFACE PLATE	6037811-001
CLS180-100	INTERFACE PLATE	6038098-001
CLS250-100	INTERFACE PLATE	6040359-001

Special End plates		
CLS100 End plate with O-ring groove		6036449-001
CLS100 Hyd/Manual internal drain end plate with additional PRV		6037180-001

Hydraulic fluid recommendations

Introduction

Oil in hydraulic systems performs the dual function of lubrication and transmission of power. It is a vital element in a hydraulic system, and careful selection should be made with the assistance of a reputable supplier. Proper selection of oil assures satisfactory life and operation of system components, especially hydraulic pumps and motors.

Generally, oil selected for use with pumps and motors is acceptable for use with valves. Critical servo valves may need special consideration.

When selecting oil for use in an industrial hydraulic system, be sure the oil:

- Contains the necessary additives to ensure excellent anti-wear characteristics
- Has proper viscosity to maintain adequate sealing and lubrication at the expected operating temperature of the hydraulic system
- Includes rust and oxidation inhibitors for satisfactory system operation

Types of hydraulic fluids

Hydraulic fluids are classified by the type of base stock used. Some fluids are further classified by fluid formulation and performance.

Anti-wear hydraulic fluids

For general hydraulic service, Eaton recommends the use of mineral base anti-wear (AW) hydraulic oils meeting Eaton specification E-FDGN-TB002-E.

Eaton requests that fluid suppliers test newly developed lubricants on Eaton 35VQ25A high pressure vane pump, according to Eaton ATS-373 test procedure, ASTM D 6973 test method and meet other requirements of the Eaton specification E-FDGN-TB002-E. Lubricants meeting the Eaton specification are considered good quality anti-wear hydraulic fluids that can be used with Eaton components at maximum allowable operating conditions. They offer superior protection against pump wear and long service life.

Crank case oils

Automotive-type crankcase oils with American Petroleum Institute (API) letter designation SE, SF, SG, SH or higher per SAE J183 classes of oils are recommended for hydraulic service. The “detergent” additive tends to hold water in a tight emulsion and prevents separation of water.

Automotive type crankcase oils generally exhibit less shear stability, which can result in higher loss of viscosity during service life.

Multiple-viscosity, industrial grade hydraulic fluids with better shear stability will provide improved viscosity control. Other mineral oil based lubricants commonly used in hydraulic systems are automatic transmission fluids (ATFs) and universal tractor transmission oils (UTTOs).

Synthetic hydrocarbon

Synthetic hydrocarbon base stocks, such as polyalphaolefins (PAOs), are also used to formulate AW hydraulic fluids, crankcase oils, ATFs and UTTOs.

Environmentally friendly hydraulic fluids

Eco-friendly characteristics is becoming a critical need, and a number of biodegradable hydraulic fluids are being used more and more in environmentally sensitive areas.

Biodegradable hydraulic fluids are generally classified as vegetable oil based (HETG), synthetic ester (HEES), polyalkylene glycol (HEPG) and polyalphaolefin (HEPR). In addition, special water glycol hydraulic fluids are used in applications in which water miscibility is necessary, along with biodegradable properties.

Fire-resistant hydraulic fluids

Fire-resistant fluids are classified as water containing fluids or synthetic anhydrous fluids. Water acts as the fire retarding agent in water containing fluids. The chemical structure of synthetic anhydrous fluids provides fire resistance.

Many applications that are prone to fire hazard, such as steel mills, foundries, die casting, mines, etc., require the use of fire resistant hydraulic fluid for improved fire safety. Fire resistant fluids may not be fireproof, but they have better fire resistance compared to mineral oil.

The alternative fluids are recommended when specific properties, such as fire resistance, biodegradability

etc., are necessary for the application. Keep in mind that alternative fluids may differ from AW petroleum fluids in properties such as pressure viscosity coefficient, specific gravity, lubricity etc. Hence certain pumps / motors may need to be de-rated, some can be operated under full ratings and others are not rated. Be sure to confirm product ratings with the specific fluid in the intended application.

Viscosity

Viscosity is the measure of a selection of hydraulic fluid with a specific viscosity range should be based on the needs of the system, limitations of critical components, or proper performance of specific types of units. At system startup and during operation, Eaton recommends maintaining the fluid's maximum and minimum viscosity ranges (see chart). Very high viscosities at startup temperatures can cause noise and cavitation damage to pumps.

Continuous operation at moderately high viscosities will tend to hold air in suspension in the fluid, as well as generate higher operating temperatures. This can cause noise, early failure of pumps and motors and erosion of valves. Low viscosities result in decreased system efficiency and impairment of dynamic lubrication, causing wear.

It is important to choose the proper fluid viscosity for your particular system in order to achieve the startup viscosity and running viscosity range (see chart) over the entire temperature range encountered. Confirm with your fluid supplier that

Hydraulic fluid recommendations

the fluid viscosity will not be less than the minimum recommended at the maximum fluid temperature of your application.

A number of anti-wear hydraulic fluids containing polymeric thickeners (Viscosity Index Improvers [VII]) are available for use in low temperature applications. Temporary or permanent viscosity loss of some of these fluids at operating temperature may adversely affect the life and performance of components. Before using polymer containing fluids, check the extent of viscosity loss (shear stability) to avoid hydraulic service below the recommended minimum viscosity. A fluid with good shear stability is recommended for low temperature applications.

Multi-grade engine oils, ATFs, UTTOs etc., also contain VIIs, and viscosity loss will be encountered during use.

Cleanliness

Fluid cleanliness is extremely important in hydraulic systems. More than 70% of all failures are caused by contamination, which can reduce hydraulic system efficiency up to 20% before system malfunction may be recognized. Different hydraulic components require different cleanliness levels. The cleanliness of a hydraulic system is dictated by the cleanliness requirement of the

most stringent component in the system. OEMs and distributors should provide their customers with cleanliness requirements for Eaton hydraulic components used in their system designs. Refer to Eaton product catalogs for specific cleanliness requirements of individual components.

Fluid maintenance

The condition of a fluid has a direct bearing on the performance and reliability of the system. Maintaining proper fluid viscosity, cleanliness level, water content, and additive level is essential for excellent hydraulic system performance. In order to maintain a healthy fluid, Eaton recommends performing periodic checks on the condition of the fluid.

System design considerations

When designing a hydraulic system, the specific gravity of the hydraulic fluid needs to be taken into consideration. If the specific gravity of the fluid is higher than that of mineral oil, be sure the reservoir fluid level is adequately above the pump inlet to meet the recommended inlet operating condition of minimum 1.0 bar absolute pressure at the pump inlet.

Filters

Proper filter type and size, which vary depending on the

type of fluid used in a system, are essential for healthy system function. The primary types of filter materials are paper, cellulose, synthetic fiber, and metal.

Filter media, adhesive, and seals must be compatible with the fluid used in the system. To lengthen fluid change out intervals, special absorbent filter media may be used to remove moisture and acids from phosphate esters.

Seals/elastomers

Select seal/elastomer materials that are suitable for the application, minimum and maximum operating temperature, and compatibility with the type of fluid used in the hydraulic system. The effect of hydraulic fluid on a particular elastomer depends on the constituents of the fluid, temperature range, and level of contaminants.

Replacing hydraulic fluid

Although sometimes valid, arbitrary hydraulic fluid change-outs can result in wasting good fluid and unnecessary machine downtime.

A regularly scheduled oil analysis program is recommended to determine when fluid should be replaced. The program should include inspection of the fluid's color, odor, water content, solid contaminants, wear metals, additive elements,

and oxidation products. Clean the system thoroughly and flush with fresh, new fluid to avoid any contamination with the previous fluid/lubricant. Replace all seals and filters with new, compatible parts. Mixing two different fluids in the same system is not recommended.

Contact your Eaton representative with questions concerning hydraulic fluid recommendations.

Viscosity requirements

Product Line	Minimum	Optimum range	Maximum allowed -startup	Cleanliness requirement (ISO 4406:99)
CMX, CML, and CLS Proportional control valves	6 cSt (45 SUS)	20-43 cSt (100-200 SUS)	2158 cSt (10,000 SUS)	18/16/14

Eaton
Hydraulics Group USA
14615 Lone Oak Road
Eden Prairie, MN 55344
USA
Tel: 952-937-9800
Fax: 952-294-7722
www.eaton.com/hydraulics

Eaton
Hydraulics Group Europe
Route de la Longeraie 7
1110 Morges
Switzerland
Tel: +41 (0) 21 811 4600
Fax: +41 (0) 21 811 4601

Eaton
Hydraulics Group Asia Pacific
Eaton Building
4th Floor, No. 3 Lane 280 Linhong Rd.
Changning District
Shanghai 200335
China
Tel: (+86 21) 5200 0099
Fax: (+86 21) 5200 0400