

*Powering Business Worldwide*

# Table of content

<b>Description</b>	<b>Page No.</b>
<b>General specifications</b>	3-5
Applications, features, and benefits	3
Specifications	4
<b>Principles of operation</b>	6 - 7
Post-compensated circuit	7
<b>Order example</b>	8 - 9
Valve bank worksheet	8
Tie rod kits and paint	9
<b>Dimensional information</b>	10 - 11
CLS250 with hydraulic top port actuation	10
CLS250 with electrohydraulic actuation	11
<b>Typical performance curves</b>	12 - 14
<b>Valve bank inlet</b>	15 - 18
Model code structure	15
Inlet build type and configuration	16
Inlet relief and dump valve options	17
<b>Working sections</b>	19 - 24
Model code structure	19
Hydraulic actuation options	21
Electrohydraulic actuation options	21
Spool flow and spool type	22
Section load sense and port relief options	24
<b>Valve bank end cover</b>	25 - 27
Model code structure	25
End cover options	26
<b>Installation and maintenance</b>	29 - 31
General torque specifications	29
Hydraulic fluid recommendations	30

# The Eaton CLS Load Sense Sectional Mobile Valve

The new Eaton CLS load sensing sectional mobile valve is a pre and post compensated mobile valve with a highly versatile design. This modularity is demonstrated through the availability of valve banks with up to 10 sections, a number of spool types and actuation options, mid-inlets, custom inlet manifolds and transition plates. With this flexibility, you can design your valve to meet the requirements of your machine. Add in the ability to install both pre and post compensated

sections in the same valve bank; the CLS allows you to prioritize work functions to accelerate productivity, improve machine efficiency, and enhance the safety characteristics of the machine.

Improve your machine performance with the newest load sensing valve to market, the Eaton CLS.

## Features & benefits

- Load sense circuit design is a parallel circuit with closed center spools. Available with inlet options to support both fixed and variable displacement pumps
- Both pre and post comp sections available in same valve assembly
- Flexible design with up to 10 sections
- Electro-proportional spool control achieved through a PWM proportional pressure reducing solenoid valve controlling pilot pressure to spool ends to maintain spool position
- Optional manual, hydraulic and electrohydraulic controls with lever overrides
- Special features available for additional design flexibility:
  - Local load sense relief on pre and post compensated sections
  - Flow control device on local section compensator
  - Adjustable spool stroke limiting device
  - Parallel connection of multiple valve banks
  - High pressure carry-over function
  - Work port relief with anti cavitation
  - Available fourth position float and regeneration spools

## Typical applications

- Excavator - Multiple sizes
- Forestry
- Refuse Trucks
- Forklift
- Agricultural machinery
- Truck Mounted Cranes
- Marine



# Specifications and performance

## CLS180 Load Sense Sectional Mobile Valve

Rated pressure	Inlet Tank port	350 bar (5076 psi) 25 bar (362 psi)
Rated inlet flow rated workport flow - post compensated		300 lpm (79.3 gpm) 250 lpm (66 gpm) @ 16 bar at differential pressure
Fluid cleanliness and viscosity		See hydraulic fluid recommendations bulletin 03-401
Ambient operating temperature range		-40°C / 60°C (-40°F / 140°F)
Oil temperature operating range		-25°C / 80°C (-16°F / 176°F)
Construction		Sectional
Work sections		1-10
Maximum leakage, cylinder workport to tank		15 cc per minute at 100 bar (1450 psi)
Port types	Inlet and tank ports	BSP G1 (ISO - 228) 1"5/8 - 12 UNF (ISO - 725) Split flange 3/4" UNC (ISO 6162-1) Split flange 3/4" MA (ISO 6162-1)
Work section options	Spools	Double acting (4 way) cylinder Bi-Directional (4 way) motor, full open to tank in neutral
	Actuation	Hydraulic with top ports Hydraulic with end ports Electrohydraulic with lever override Electrohydraulic only
Coil voltages		12 Volt DC 24 Volt DC
Coil connectors		Integral Deutsch DT04-2P Amp Jr. Timer
Electrohydraulic interface		Eaton HFX programmable controllers and Pro-FX™ application software

# Specifications and performance

<b>General Specifications</b>	<b>CLS100</b>	<b>CLS180</b>	<b>CLS250</b>	<b>CLS350</b>
Max number of working sections	10	10	10	8
Sectional nominal thickness (mm)	38	46	54	72
Spool stroke (mm)	7	8	9	11
<b>Rated flow</b>				
Pump flow rate (l/min)	150	220	300	450
A/B work port flow rate (l/min) <i>(Post-compensated/pre-compensated with 14 bar Δp)</i>	100/65	180	250	350
<b>Rated pressure</b>				
Working pressure inlet port P (bar)	350	350	350	350
<b>Back pressure max</b>				
Max pressure outlet port T (bar) <i>(Under special conditions back pressure can be lower)</i>	25	25	25	25
<b>Compensation Type</b>	<b>CLS100</b>	<b>CLS180</b>	<b>CLS250</b>	<b>CLS350</b>
Pre compensation	•			
Post compensation	•	•	•	•
<b>Option Chart</b>	<b>CLS100</b>	<b>CLS180</b>	<b>CLS250</b>	<b>CLS350</b>
LS signal pressure relief valve	•	•	•	•
Pump pressure relief valve	•	•	•	•
LS signal dump valve (electric 12/24 Vdc)	•	•	•	•
Pump dump valve (electric 12/24 Vdc)	•	•	•	
<b>Spool Types</b>	<b>CLS100</b>	<b>CLS180</b>	<b>CLS250</b>	<b>CLS350</b>
Double acting (4 way) cylinder	•	•	•	•
Double acting (4 way) cylinder with 4th position float	•			
Bi-directional (4 way) motor, full open to tank in neutral	•	•	•	•
Double acting (4 way/ 3 position) cylinder with regeneration	•			
<b>Spool Actuation</b>	<b>CLS100</b>	<b>CLS180</b>	<b>CLS250</b>	<b>CLS350</b>
Hydraulic actuation with hydraulic ports	•	•	•	•
Hydraulic actuation with hydraulic ports and lever override	•			
Electrohydraulic proportional actuation	•	•	•	•
Electrohydraulic proportional actuation with lever override	•	•	•	•
Electrohydraulic actuation with hydraulic ports	•			
Electrohydraulic actuation with hydraulic ports and lever override	•			
Manual actuation with enclosed lever box	•	•		
Manual actuation with exposed spool end	•	•		
Manual actuation with pneumatic pilot ports	•	•		
CAN BUS interface actuation				•
<b>Port Relief Valve</b>	<b>CLS100</b>	<b>CLS180</b>	<b>CLS250</b>	<b>CLS350</b>
Relief valve			•	•
Anticavitation valve	•	•	•	•
Combined relief and anticavitation valve	•	•	•	•
Cavity machined and plugged	•	•	•	•
<b>Special Features</b>	<b>CLS100</b>	<b>CLS180</b>	<b>CLS250</b>	<b>CLS350</b>
Spools position sensor	•	•		
Spool stroke limiter	•	•	•	•
Section flow limiter	•	•		
Section load sense pressure limiting relief*	•	•		
Section remote load sense pressure limiting relief*	•	•		

\*Applies to local work ports

# CLS Load Sense Sectional Mobile Valve

## Description

### Operating principle

The CLS valve, completely pressure compensated, guarantees great controllability to all actuations, making workport flow dependent only on metering area (spool position). When flow saturation occurs the system reacts by implementing an equal reduction of pressure margin across all spools, generating a proportional reduction of workport flow.

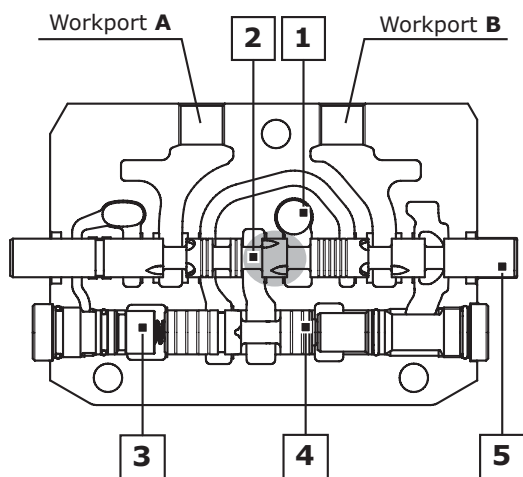

### Legend:

1. Inlet line (high pressure)
2. Metering notches
3. Load sensing line
4. Local compensator
5. Metering spool

### Single section

Referencing the picture to the left reveals some aspects of system functionality. From the inlet line, the high pressure flow passes across the metering area and down to the local compensator. The metering area, according to the pressure margin, controls the total amount of flow to the work-port selected by the main spool. The load sensing signal, picked up downstream of the local compensator, feeds the common load-sensing line. When a single section is actuated, the local compensator fully opens to the left side, reaching its complete balanced position. The control of the LS system is achieved by the inlet compensator for fixed displacement pumps or the pump compensator for variable displacement pumps.

### Multi-section

When two or more sections are actuated, only the function characterized by the highest pressure (dominant) is involved in the LS signal transmission. The other functions become directly dependent on it (slaves). The common LS line transfers the signal from the dominant local compensator to all dependent compensators. Driven by the LS signal, the unbalanced slave compensators activate the pressure compensation creating an artificial pressure drop able to keep pressure margin nominally the same on all the spools. Workport flow becomes only a function of metering area making the system totally load independent.

### Flow sharing section

Saturation occurs when the total amount of flow required by the valve bank is greater than the maximum pump flow rate. In this condition the system is not able to maintain the nominal pressure margin, reducing the margin according to real flow demand. As a result all the local section compensators experience the same LS signal and the same pressure drop is applied to different metering areas, reducing work-port flows proportionally in order to keep all actuations completely under control.

# CLS Load Sense Sectional Mobile Valve

## Description

The CLS valve line allows the customer the ability to combine pre and post compensated valve sections in the same valve bank. The pre compensated section acts as a priority flow sharing function by diverting flow to the pre compensated function first, then to the remaining sections in the bank.

The following schematics show an example of an all post-compensated system, and a system with an integrated pre compensated section.

### Post compensated system - Electrohydraulic actuation

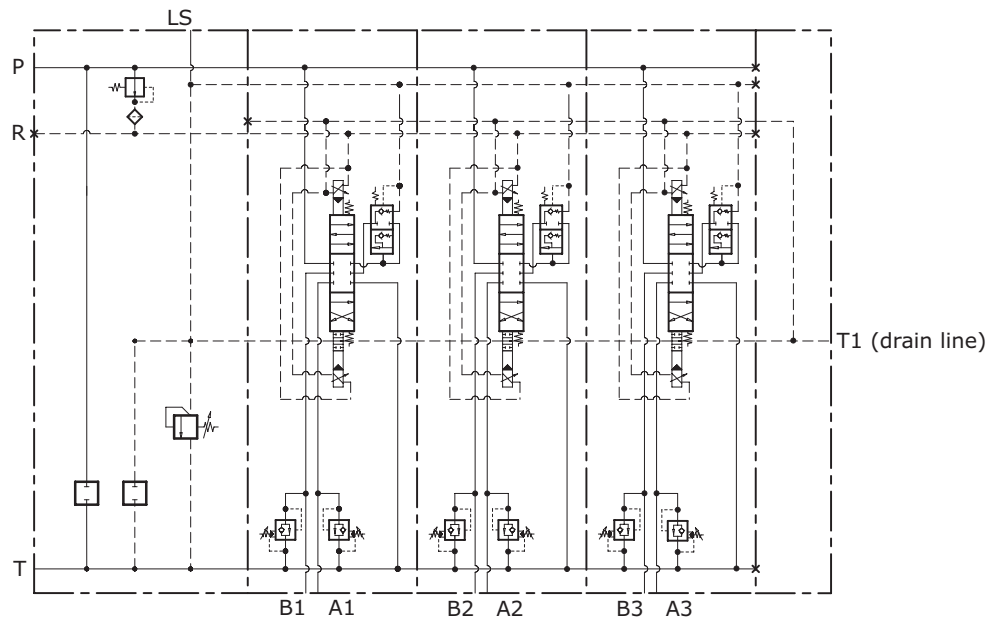

### Post compensated system - Hydraulic actuation

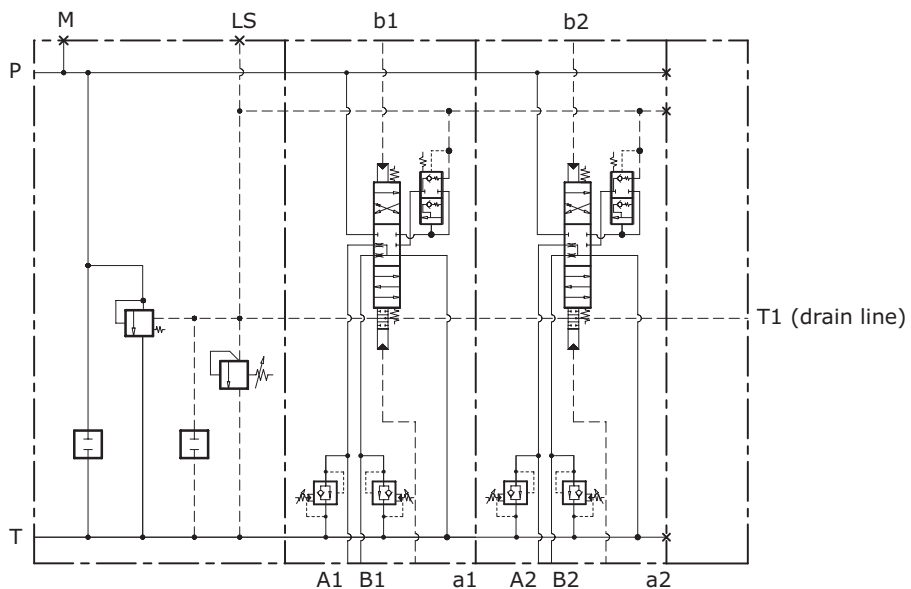

# CLS250 Load Sense Sectional Mobile Valve

Ordering example

## Valve Bank Order Example

1) Inlet	CLS250-RUS-D300350-ZZ-00-A
2) Section 1	CLS251-PES-DA250250-C-P000-P000-Z000-ZZ-00-A
3) Adaptor plate	6037811-001 - EH ADAPTOR CLS250-CLS180
4) Section 2	CLS181-PES-DA180180-C-R150-R200-Z000-ZZ-00-A
5) Section 3	CLS181-PES-DA180180-C-A000-A000-Z000-ZZ-00-A
6) Section 4	CLS181-PES-DA180180-C-R150-R200-Z000-ZZ-00-A
7) Section 5	CLS181-PES-DA180180-C-R150-R200-Z000-ZZ-00-A
8) End cover	CLS182-HS-00-A
9) Tie rod kit 1	CLS250/1 6038789-001
10) Tie rod kit 2	CLS180/4 6038226-004
11) Paint	AU flat black

Note: Repeat section model code for additional sections.

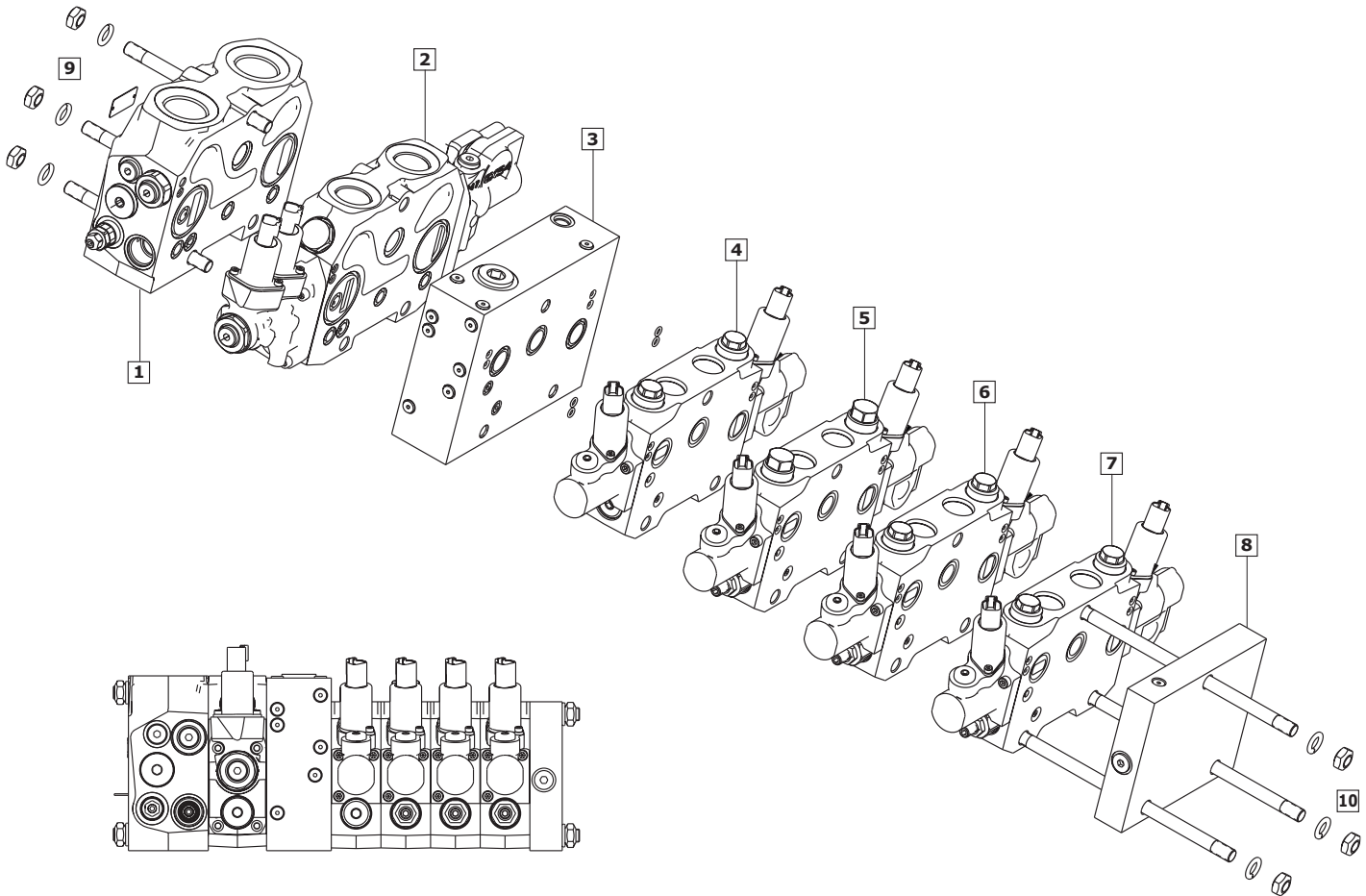



# CLS250 Load Sense Sectional Mobile Valve

## Tie rod kits

Tie rod kits are required to complete a valve bank assembly. Tie rod length depends on the number of sections in the bank. Each tie rod kit includes three (3) tie rods, three (3) nuts and three (3) washers.

Tie Rod Kit	Desc.	Pn	Length (Mm)	Clamping Torque (Nm)
CLS100/1	1 Sect.	6038225-001	95	40
CLS100/2	2 Sect.	6038225-002	133	
CLS100/3	3 Sect.	6038225-003	172	
CLS100/4	4 Sect.	6038225-004	210	
CLS100/5	5 Sect.	6038225-005	248	
CLS100/6	6 Sect.	6038225-006	287	
CLS100/7	7 Sect.	6038225-007	324	
CLS100/8	8 Sect.	6038225-008	361	
CLS100/9	9 Sect.	6038225-009	400	
CLS100/10	10 Sect.	6038225-010	438	

Tie Rod Kit	Desc.	Pn	Length (Mm)	Clamping Torque (Nm)
CLS180/1	1 Sect.	6038226-001	176	70
CLS180/2	2 Sect.	6038226-002	222	
CLS180/3	3 Sect.	6038226-003	268	
CLS180/4	4 Sect.	6038226-004	314	
CLS180/5	5 Sect.	6038226-005	360	
CLS180/6	6 Sect.	6038226-006	406	
CLS180/7	7 Sect.	6038226-007	452	
CLS180/8	8 Sect.	6038226-008	498	
CLS180/9	9 Sect.	6038226-009	544	
CLS180/10	10 Sect.	6038226-010	590	

Tie Rod Kit	Desc.	Pn	Length (Mm)	Clamping Torque (Nm)
CLS250/1	1 Sect.	6038789-001	192	60
CLS250/2	2 Sect.	6038789-002	246	
CLS250/3	3 Sect.	6038789-003	300	
CLS250/4	4 Sect.	6038789-004	354	
CLS250/5	5 Sect.	6038789-005	408	
CLS250/6	6 Sect.	6038789-006	462	
CLS250/7	7 Sect.	6038789-007	516	
CLS250/8	8 Sect.	6038789-008	570	
CLS250/9	9 Sect.	6038789-009	624	
CLS250/10	10 Sect.	6038789-010	678	

Transition Plates	Description	Pn	Code	Coloring
CLS180/100	Electrohydraulic adaptor plate	6038080-001	AU	Standard flat black
CLS180/100	Hydraulic or manual adaptor plate	6037913-001	00	No paint
CLS250/180	EH adaptor plate	6037811-001		

# CLS250 Load Sense Sectional Mobile Valve

CLS250 with hydraulic top port actuation

Units: mm

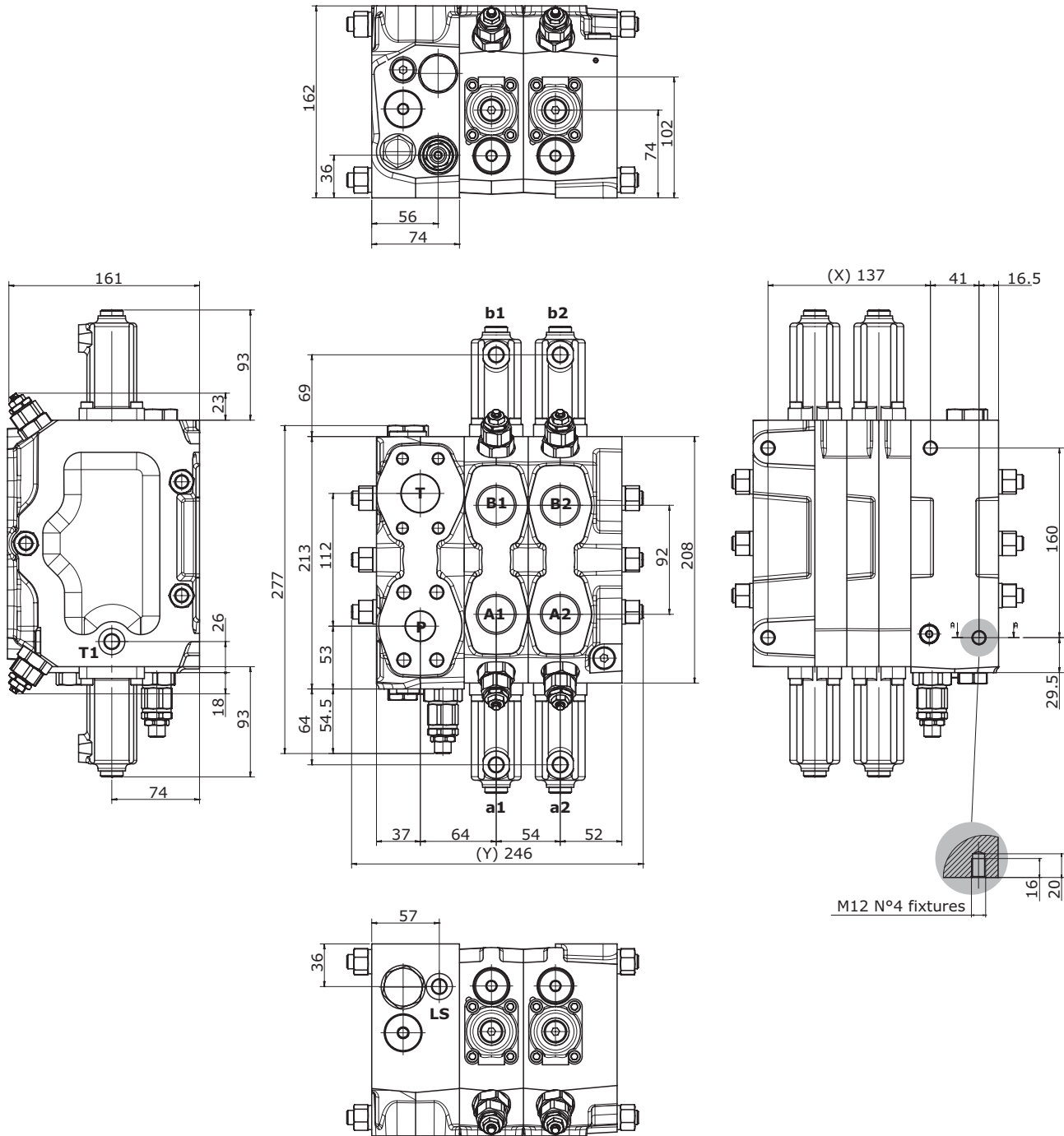

Dimension	Number of sections							
	/1	/2	/3	/4	/5	/6	/7	/8
X (mm)	83	137	191	245	299	353	407	461
Y (mm)	192	246	300	354	408	462	516	570
Weights (kg)	32	43	54	65	76	87	98	109

# CLS250 Load Sense Sectional Mobile Valve

CLS250 with electrohydraulic actuation

Units: mm

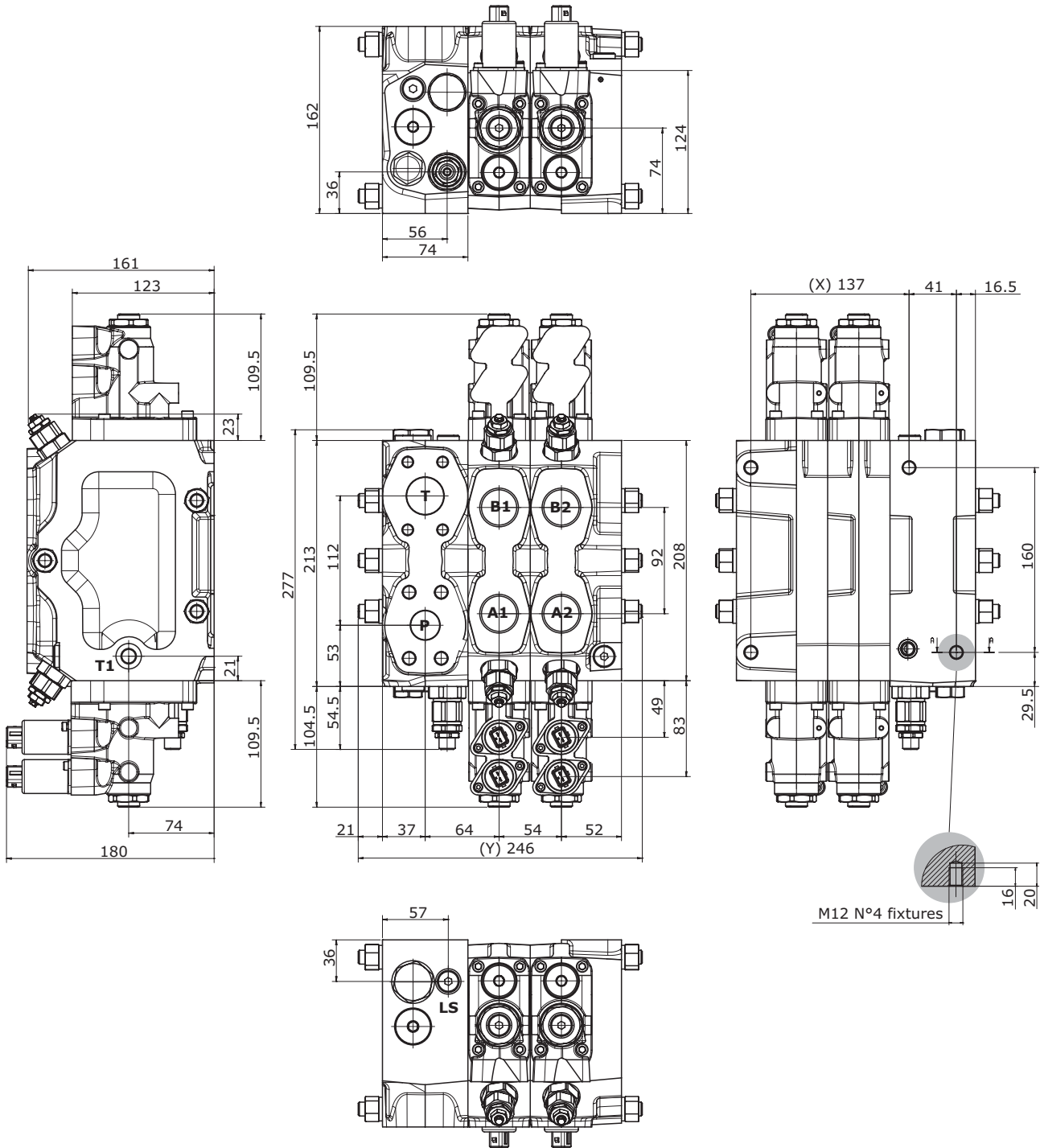

Dimension	Number of sections							
	/1	/2	/3	/4	/5	/6	/7	/8
X (mm)	83	137	191	245	299	353	407	461
Y (mm)	192	246	300	354	408	462	516	570
Weights (kg)	32	43	54	65	76	87	98	109

# CLS250 Load Sense Sectional Mobile Valve

Typical curves

## Inlet compensator pressure drop (P-T)

Fixed displacement system: pressure drop across the inlet compensator as function of pump flow

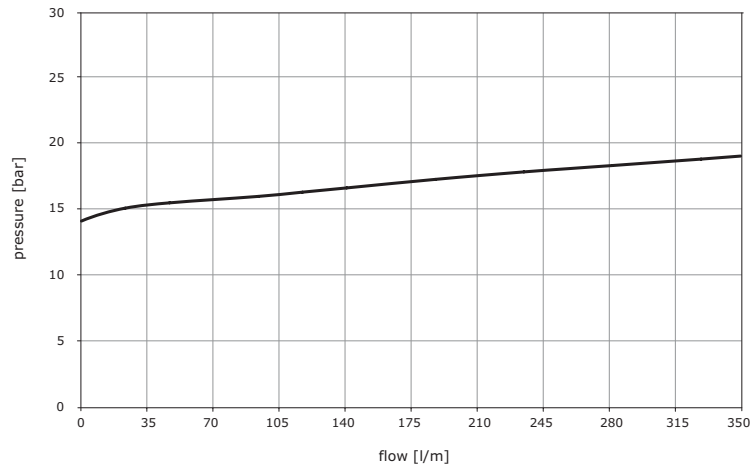

## LS signal pressure relief valve

Fixed displacement system: LS signal pressure relief valve characteristic

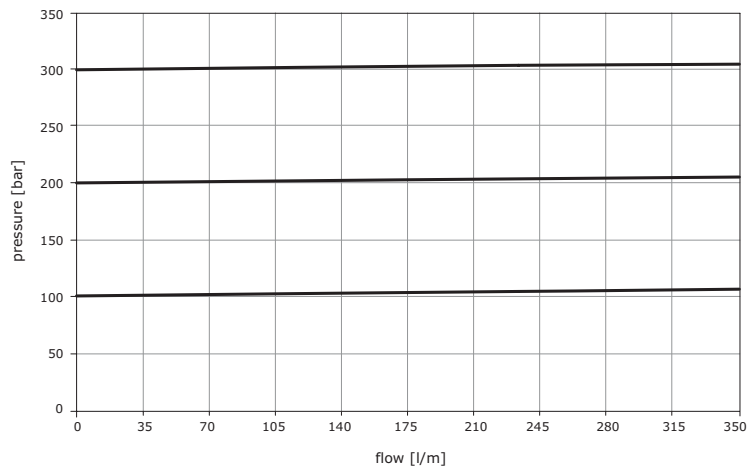

# CLS250 Load Sense Sectional Mobile Valve

Typical curves

## Post compensated spool flow characteristic

Fixed displacement systems:  
flow on ports A and B as  
function of spool stroke, pilot  
pressure, control current  
Inlet flow: 300 l/min

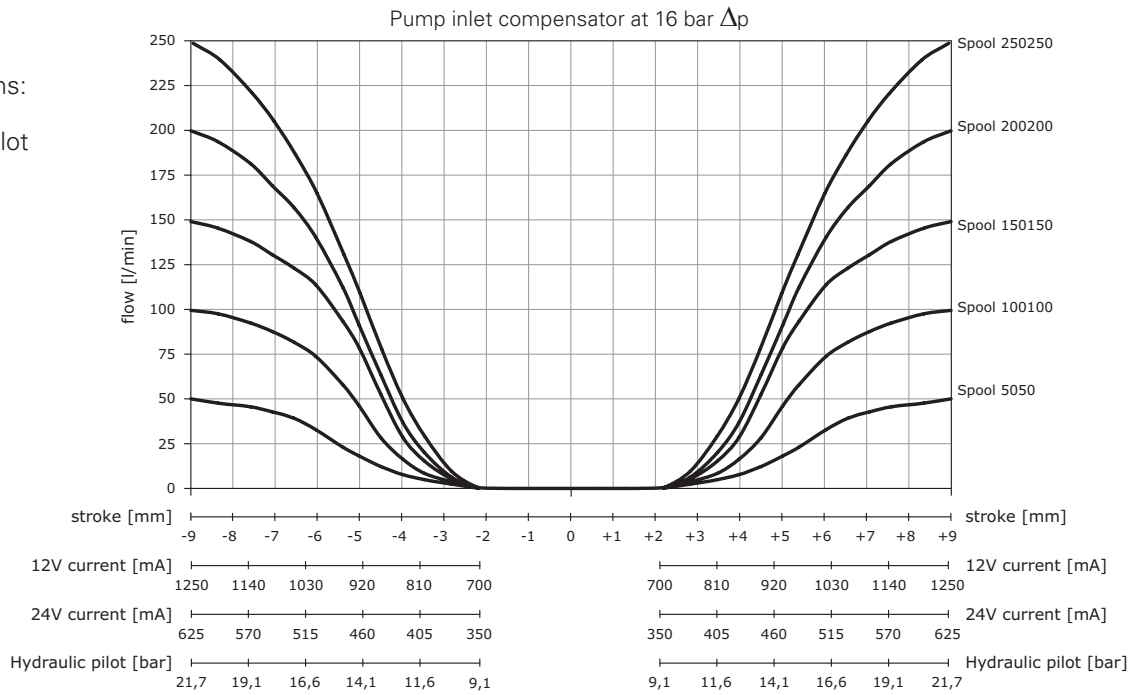

## Post compensated spool flow with variable displacement pumps

Variable displacement  
systems: spools maximum  
delivered flow as function of  
pump  $\Delta P$  setting

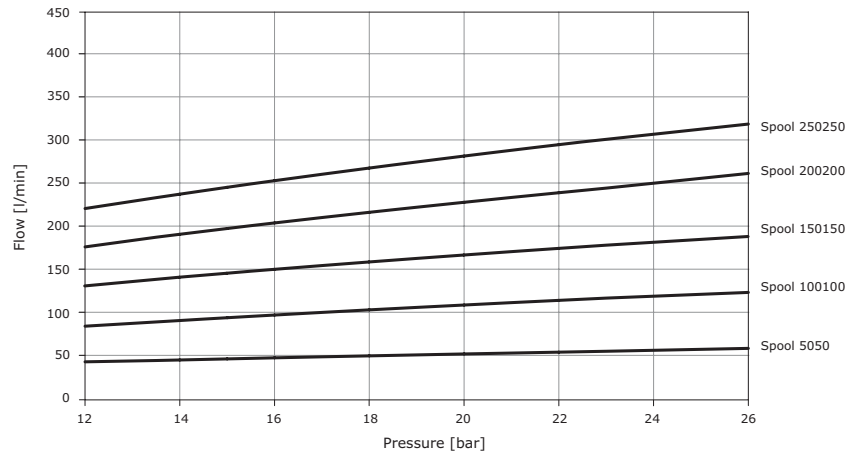

# CLS250 Load Sense Sectional Mobile Valve

Typical work port auxiliary valve curves

## Combined valves (relieving function)

Pressure characteristic as function of flow

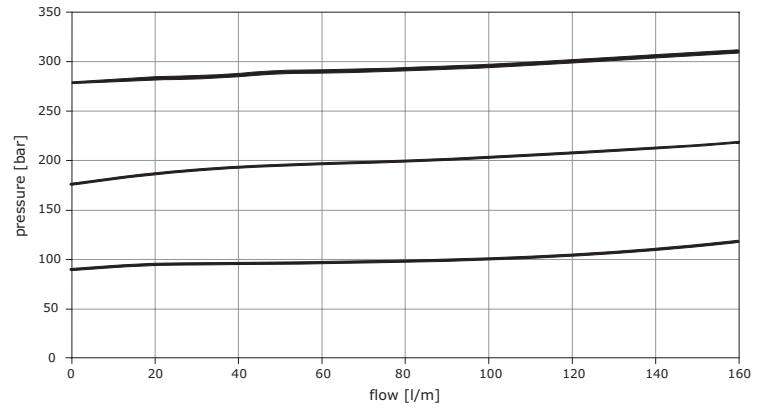

## Combined valves (anticavitation function)

Opening and pressure characteristic as function of flow

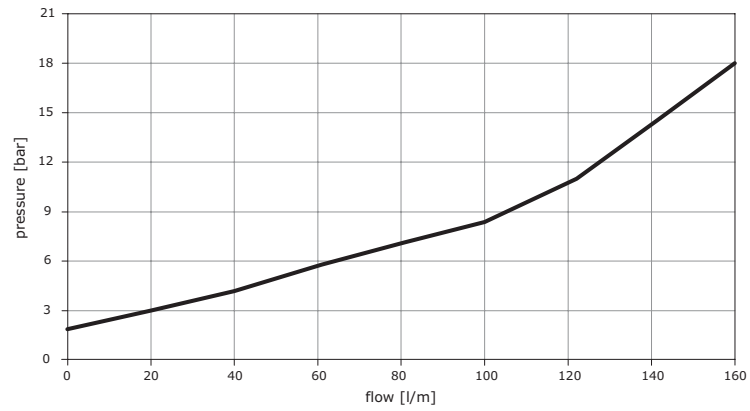

# Model code for valve bank inlet

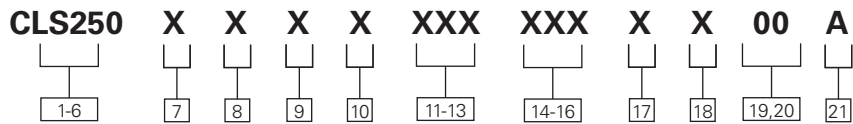

## 1-6 Product series

**CLS250** – Load sense sectional mobile valve: standard valve bank inlet

## 7 Inlet build

**R** – Right hand build  
**L** – Left hand build

## 8 Inlet type

**L** – Load sensing  
**U** – Unload for open center

## 9 Inlet ports

**B** – BSP (P - G 1" 1/4, T - G 1" 1/4)  
**S** – SAE (P - 1" 5/8 - 12 UNF, T - 1" 5/8 - 12 UNF)  
**F** – Split flange (P - 1" UNC ISO 6162-2, T - 1" 1/4 UNC ISO 6162-1)  
**G** – Split flange (P - 1" MA ISO 6162-2, T - 1" 1/4 MA ISO 6162-1)

## 10 Inlet reliefs

**D** – LS & full flow reliefs  
**L** – LS relief only  
**R** – Full flow relief only  
**Z** – No reliefs

## 11-13 Load sense relief setting

**XXX** – 3 Digit load sense relief setting in 5 Bar increments, code 000 if none  
Note: 0-350 bar  
Requires minimum 40 bar difference in setting of full flow and LS relief valves.

## 14-16 Full flow relief setting

**XXX** – 3 Digit full flow relief setting in 5 bar increments, code 000 if none  
Note: 0-420 bar  
Requires minimum 40 bar difference in setting of full flow and LS relief valves.

## 17 Inlet dump valve

**F** – Full flow dump valve  
**L** – LS dump valve  
**Z** – No dump valve

## 18 Inlet coil

**A** – 12V Coil with DIN connector  
**B** – 24V Coil with DIN connector  
**C** – 12V Coil Deutsch connector  
**D** – 24V Coil Deutsch connector  
**E** – 12V Coil AmpJr connector  
**F** – 24V Coil AmpJr connector  
**Z** – No coil

## 19-20 Special features

**00** – No special features

## 21 Design level

**A** – Initial release

# CLS inlet - build and type

Dimensions and configurations for model code positions 9 & 10

## R - Right hand build

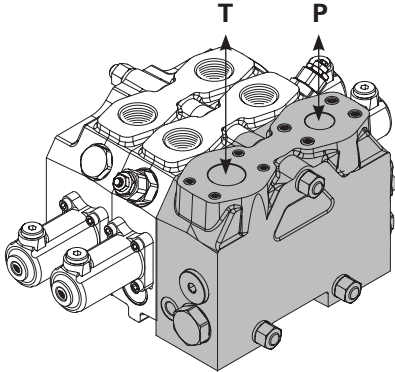

## L - Left hand build

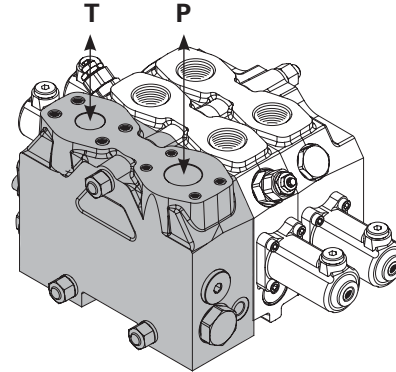

## L - Load sensing

Closed center inlet section for variable displacement pumps

The inlet section with L configuration enables control valve usage with variable displacement pumps. With this configuration the presence of LS relief valve (A) is suitable to adjust the system maximum pressure. A LS electric dump valve can also be added as a safety device. An additional full flow relief valve can be added to protect the system from pump regulator failures. An additional solution for variable displacement pumps is available on request to allow a constant reduced free flow in stand by condition through the system: this is sometimes required to guarantee a stand by flow for oil cooling.

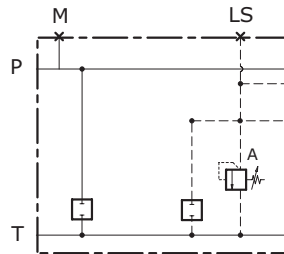

Schematic represents inlet for valve bank consisting of only sections operated by hydraulic ports.

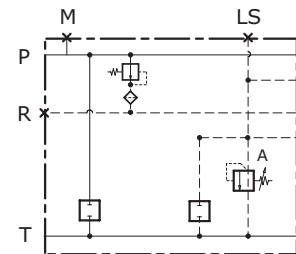

Schematic represents inlet for valve bank where any of the sections are operated using an EH solenoid pilot valve, requiring the presence of a pressure reducing valve.

## U - Unload for open center

Open center inlet section for fixed displacement pumps

The inlet section with U configuration enables control valve usage with fixed displacement pumps. With this configuration the presence of LS relief valve (A) is suitable to adjust the system maximum pressure. A full flow electric dump valve can also be added as a safety device.

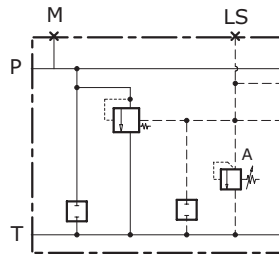

Schematic represents inlet for valve bank consisting of only sections operated by hydraulic ports.

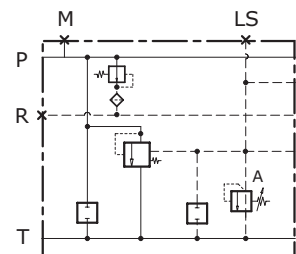

Schematic represents inlet for valve bank where any of the sections are operated using an EH solenoid pilot valve, requiring the presence of a pressure reducing valve.



# CLS inlet - relief valve options

Schematics and configurations for model code position 12

## D - LS & full flow reliefs

**Note:**  
This combination requires that the full flow relief be set at least 40 bar higher than the LS relief.

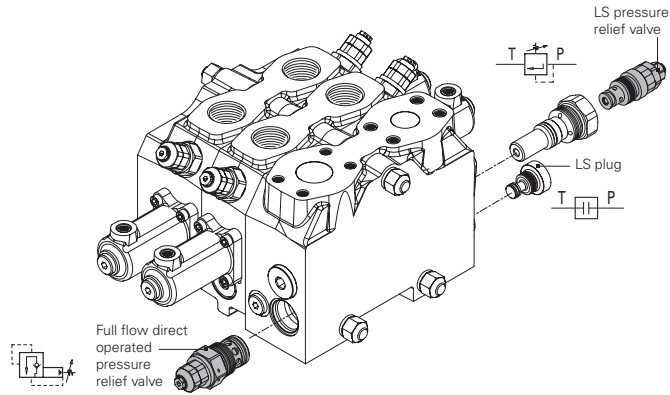

## L - LS relief only

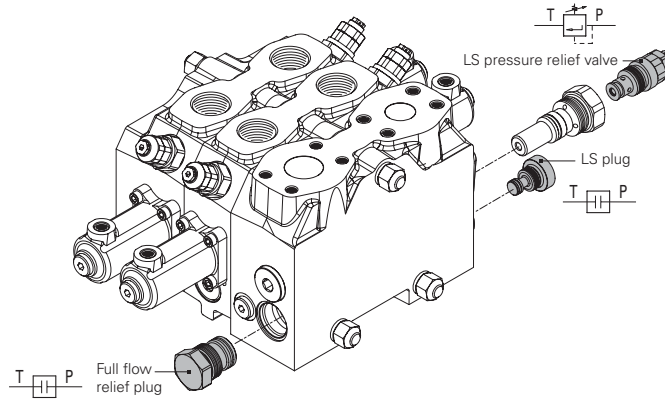

## R - Full flow relief only

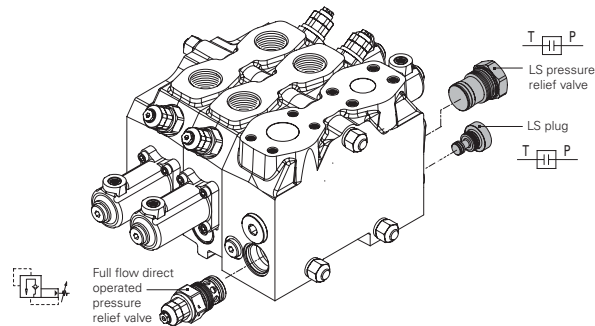

# CLS inlet - dump valve options

Model code positions 19 & 20

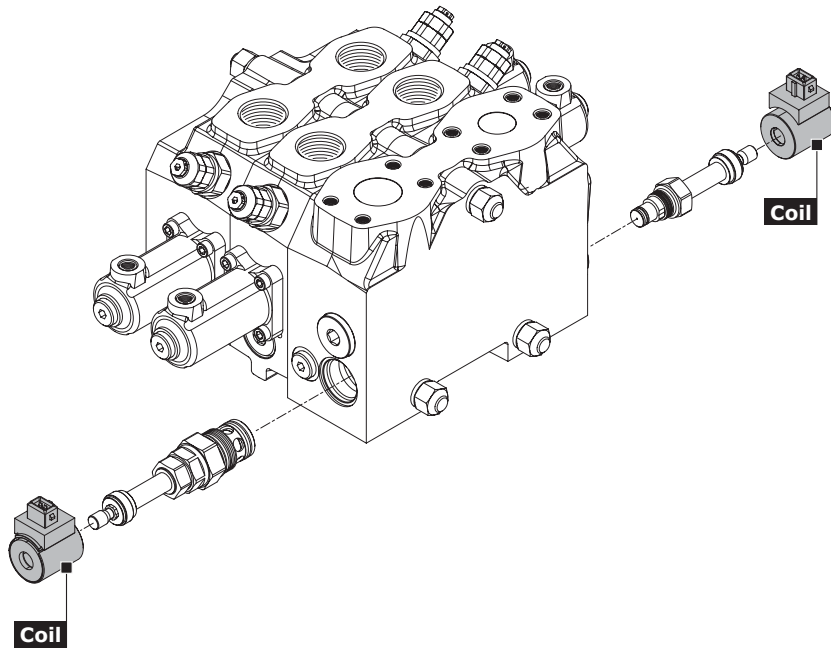

## Coil and connectors specifications for inlet section

Option	Supply Voltage (Vdc)	Connector	Ingress Rating	Coil Resistance R20 (Ω)	Connector Material	Coil Body	Duty Cycle	Coil Insulation	Power
A	12	DIN	IP 65	7	Nylon	Zinc plated steel	ED 100%	Class H coil - IEC 85 Standard (200°C)	20.5 W
B	24	DIN	IP 65	28					
C	12	Deutsch	IP 67	7					
D	24	Deutsch	IP 67	28					
E	12	AmpJr	IP 65	7					
F	24	AmpJr	IP 65	28					

### F - Full flow dump valve

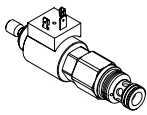
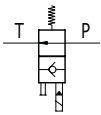

### L - LS Electric dump valve

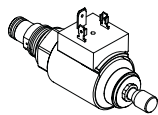
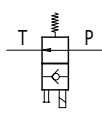

# Model code for sections

The following 35 digit coding system has been developed to identify preferred feature options for the CLS250 Load Sense Sectional Mobile Valve series. Use this code to specify a valve with the desired features. All 35-digits of the code must be present to release a new product number for ordering.

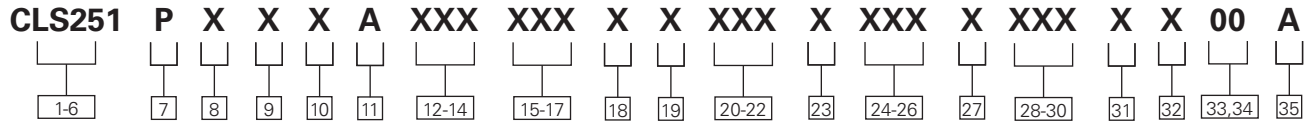

<p><b>1-6 Product series</b></p> <p><b>CLS250</b> – Load sense sectional mobile valves</p>	<p><b>10 Spool type</b></p> <p><b>D</b> – Double acting (4 Way) cylinder</p> <p><b>H</b> – Bi-directional (4 Way) motor, full open to tank in neutral</p>	<p><b>19 Port A option function</b></p> <p><b>A</b> – Anti-cav</p> <p><b>B</b> – Relief</p> <p><b>R</b> – Relief/Anti-cav</p> <p><b>P</b> – Work port cavities machined and plugged</p>	<p><b>27 LS relief setting</b></p> <p><b>P</b> – EH and hydraulic section - local load sense relief (applies to both A and B ports)</p> <p><b>Z</b> – No LS relief</p>
<p><b>7 Compensation</b></p> <p><b>P</b> – Post-compensated</p>	<p><b>11 Spool action</b></p> <p><b>A</b> – Spring centered to neutral</p>	<p><b>20-22 Port A option setting</b></p> <p><b>XXX</b> – 040-350 (3 digit, in 10 bar increments), relief valve pressure setting, port A</p>	<p><b>28-30 LS relief setting</b></p> <p><b>XXX</b> – 3 Digit section LS relief setting in bar (000 if not present or if using remote LS relief)</p>
<p><b>8 Actuation</b></p> <p><b>A</b> – Hydraulic with top ports</p> <p><b>C</b> – Hydraulic with end ports</p> <p><b>E</b> – Electrohydraulic with lever override</p> <p><b>F</b> – Electrohydraulic only</p>	<p><b>12-14 Port A spool flow</b></p> <p><b>050</b> – 50 l/m</p> <p><b>100</b> – 100 l/m</p> <p><b>150</b> – 150 l/m</p> <p><b>200</b> – 200 l/m</p> <p><b>250</b> – 250 l/m</p>	<p><b>23 Port B option function</b></p> <p><b>A</b> – Anti-cav</p> <p><b>B</b> – Relief</p> <p><b>R</b> – Relief/Anti-cav</p> <p><b>P</b> – Work port cavities machined and plugged</p>	<p><b>31 Spool stroke limiter or position indicator</b></p> <p><b>A</b> – Electrohydraulic section w/Spool stroke limiter</p> <p><b>Z</b> – None</p>
<p><b>9 Port type</b></p> <p><b>B</b> – BSP G1 (ISO - 228)</p> <p><b>S</b> – 1”5/8 - 12 UNF (ISO - 725)</p> <p><b>F</b> – Split flange 3/4” UNC (ISO 6162-1)</p> <p><b>G</b> – Split flange 3/4” MA (ISO 6162-1)</p>	<p><b>15-17 Port B spool flow</b></p> <p><b>050</b> – 50 l/m</p> <p><b>100</b> – 100 l/m</p> <p><b>150</b> – 150 l/m</p> <p><b>200</b> – 200 l/m</p> <p><b>250</b> – 250 l/m</p>	<p><b>24-26 Port B option setting</b></p> <p><b>XXX</b> – 040-350 (3 digit, in 10 bar increments), relief valve pressure setting, port B</p>	<p><b>32 Lever kits</b></p> <p><b>A</b> – 135mm (5.5”) Lever Kit</p> <p><b>B</b> – 210mm (8.5”) Lever Kit</p> <p><b>Z</b> – None</p>
	<p><b>18 Coil type</b></p> <p><b>C</b> – 12V coil Deutsch connector</p> <p><b>D</b> – 24V coil Deutsch connector</p> <p><b>E</b> – 12V coil AmpJr connector</p> <p><b>F</b> – 24V coil AmpJr connector</p> <p><b>Z</b> – No coil</p>	<p><b>33,34 Special features</b></p> <p><b>00</b> – No special features</p>	<p><b>35 Design level</b></p> <p><b>A</b> – Initial release</p>

# Valve section options - compensation

Model code position 7

## P - Post compensated (flow sharing)

Only available with auxiliary ports, select plugs if no port reliefs required.

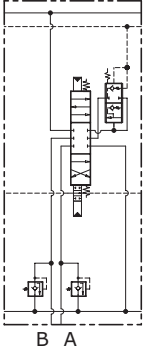

Mechanical Lever  
Actuation

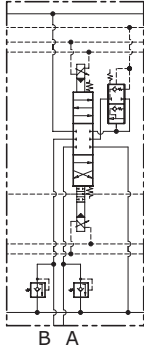

Electrohydraulic  
Actuation

# Valve section options - actuation for hydraulic control

Dimensions and configurations for model code position 8

Units: mm

## A - Hydraulic with top ports

Hydraulic actuation (pilot ports on the top)

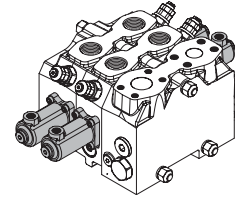
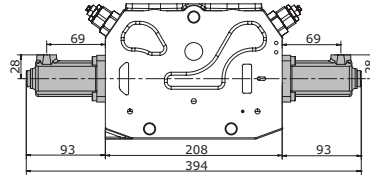

## C - Hydraulic with end ports

Hydraulic actuation (pilot ports on the sides)

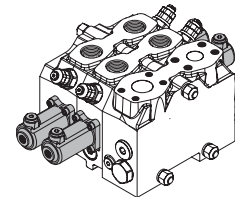
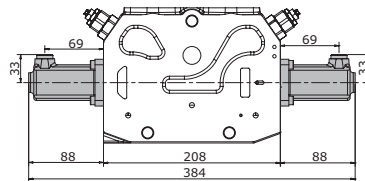

# Valve section options - actuation for electrohydraulic control

Dimensions and configurations for model code position 8

## E - Electrohydraulic with lever override

Note:  
Includes solenoid operated pilot valve

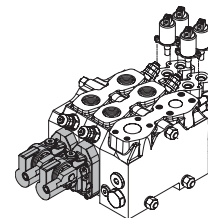
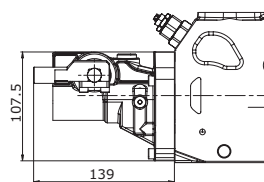

## F - Electrohydraulic only

Without lever

Note:  
Includes solenoid operated pilot valve

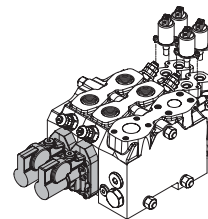
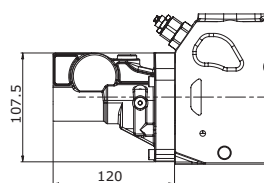

# Valve section options - spool type

Model code position 10

**D -  
Double acting (4 way)  
cylinder**

**H -  
Bi-directional (4 way)  
motor, full open to tank  
in neutral**

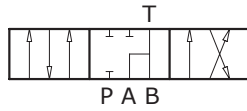
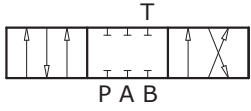

# Valve section options - spring action options

Model code position 11

**A -  
spring centered in neutral**

# Valve section options - port a & port b spool flows

Model code positions 12-14 (port a) & model code positions 15-17 (port b)

## Post Compensated Section

Spool Type	Flow Rates (l/min)				
	050	100	150	200	250
D	•	•	•	•	•
H	•	•	•	•	•

Note: Rated flows are defined for 16 bar  $\Delta p$ .

Listed flows are for symmetrical spools; for questions regarding asymmetric spools please contact your sales representative.

# Valve section options - coil voltage & connector

Model code position 18

## Coil and connector specifications

Option	Supply Voltage (Vdc)	Connector	Ingress Rating	Coil Resistance R20 (Ω)	Feeding Reducing Pressure	Prop. Current Control (mA)	Duty Cycle	Pwm Suggested Frequency (Hz)
C	12	Deutsch DT4	IP 67	4.7	40 bar	600-1300	2500	70-90
D	24	Deutsch DT4	IP 67	20.8		300-650	1150	
E	12	Amp Jr	IP 65	4.7		600-1300	2500	
F	24	Amp Jr	IP 65	20.8		300-650	1150	

# Valve section options - port a & port b functions and settings

Model code positions 20-26

## A - Anti-cav

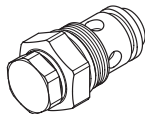

## B - Relief

Note: Factory setting 50-350 bar

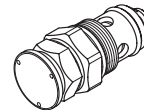

## P - Plugged - work port of is relief cavities machined and plugged

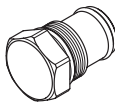

## R - Relief/Anti-cav

Note: Factory setting 40-350 bar

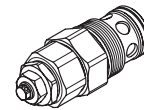

# Valve section options - load sense relief setting

Model code position 28

## P - Post compensated - section load sense relief (applies to both a & b ports)

Schematic for manual control

Schematic for electrohydraulic control

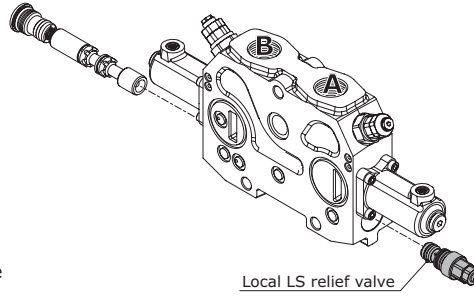
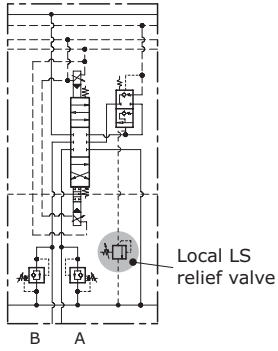
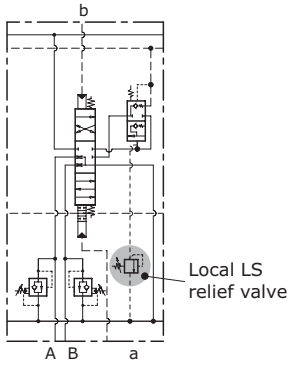

Note: Post comp load sense relief range is 0-350 bar.  
Requires left valve bank inlet selection



# Valve section options - spool stroke limiter or position indicator

Dimensions and configurations for model code position 32

Units: mm

## A - Electrohydraulic section with spool stroke limiter

with lever override

Note:  
Can be applied to sections with  
Lever Override

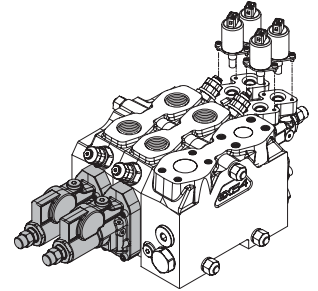
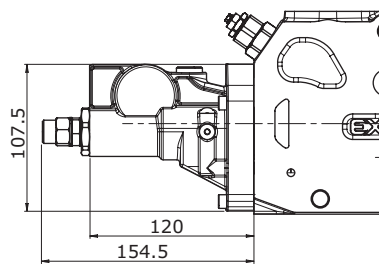

## B - Hydraulic section with spool stroke limiter

Hydraulic actuation with  
stroke limiter

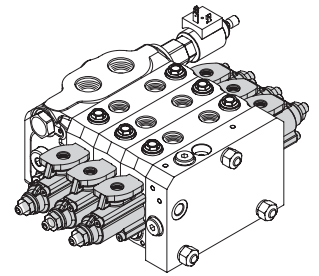
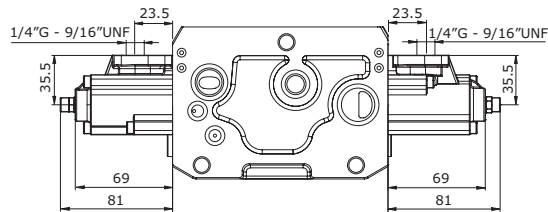

# Valve section options - lever kits

Model code position 33

## A - 135 Lever kit

Lever with knob - 135mm (5.5")

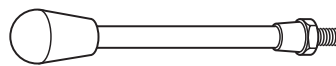

## B - 210 Lever kit

Lever with knob - 210mm (8.5")

# Model code for valve bank end cover section

The following 36 digit coding system has been developed to identify preferred feature options for the CLS250 Load Sense Sectional Mobile Valve End Cover Section. **Please note** that an end cover section includes all the standard features of a CLS250 section (pages 20-25) with the addition of load sense drain ports (page 27). All 36-digits of the code must be present to release a new product number for ordering.

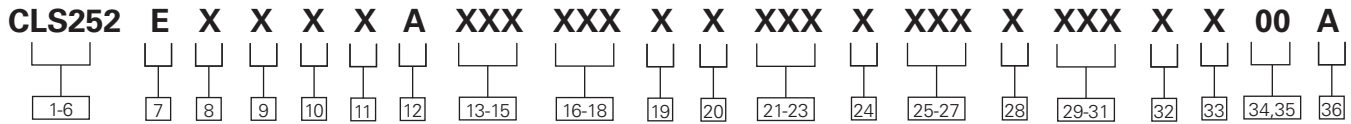

## 1-6 Product series

**CLS252** – Valve section

## 7 Compensation

**E** – Standard end cover section

## 8 Actuation

**A** – Hydraulic with top ports  
**C** – Hydraulic with end ports  
**E** – Electrohydraulic with lever override  
**F** – Electrohydraulic only

## 9 end cover load sense drain

**H** – Hydraulic with external LS end-rear drain  
**K** – Hydraulic with external LS drain on top  
**F** – Electrohydraulic with external LS end-rear drain  
**G** – Electrohydraulic with external LS drain on top

## 10 Port type

**B** – BSP G1 (ISO - 228)  
**S** – 1”5/8 - 12 UNF (ISO - 725)  
**F** – Split flange 3/4” UNC (ISO 6162-1)  
**G** – Split flange 3/4” MA (ISO 6162-1)

## 11 Spool type

**D** – Double acting (4 way) cylinder  
**H** – Bi-directional (4 way) motor, full open to tank in neutral

## 11 Spool action

**A** – Spring centered to neutral

## 13-15 Port A spool flow

**050** – 50 l/m  
**100** – 100 l/m  
**150** – 150 l/m  
**200** – 200 l/m  
**250** – 250 l/m

## 16-18 Port B spool flow

**050** – 50 l/m  
**100** – 100 l/m  
**150** – 150 l/m  
**200** – 200 l/m  
**250** – 250 l/m

## 19 Coil type

**C** – 12V coil Deutsch connector  
**D** – 24V coil Deutsch connector  
**E** – 12V coil AmpJr connector  
**F** – 24V coil AmpJr connector  
**Z** – No coil

## 20 Port A option function

**A** – Anti-Cav  
**B** – Relief  
**R** – Relief/Anti-cav  
**P** – Work port cavities machined and plugged

## 21-23 Port A option setting

**XXX** – 040-350 (3 digit, in 10 bar increments), relief valve pressure setting, port A

## 24 Port B option function

**A** – Anti-cav  
**B** – Relief  
**R** – Relief/Anti-cav  
**P** – Work port cavities machined and plugged

## 25-27 Port B option setting

**XXX** – 040-350 (3 digit, in 10 bar increments), relief valve pressure setting, port B

## 28 LS relief setting

**P** – EH and hydraulic section - local load sense relief (applies to both A and B ports)  
**Z** – No LS relief

## 29-31 LS relief setting

**XXX** – 3 digit dection LS relief setting in bar (000 if not present or if using remote LS relief)

## 32 Spool Stroke Limiter or Position Indicator

**A** – Electrohydraulic section w/Spool stroke limiter  
**Z** – None

## 33 Lever kits

**A** – 135mm (5.5”) lever kit  
**B** – 210mm (8.5”) lever kit  
**Z** – None

## 34,35 Special features

**00** No special features

## 36 Design level

**A** – Initial Release

# CLS assembly - end cover sections

Schematics and configurations for model code position 9

## H - Hydraulic with external LS end-rear drain

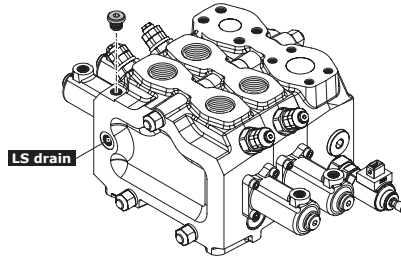

## K - Hydraulic with external LS drain on top

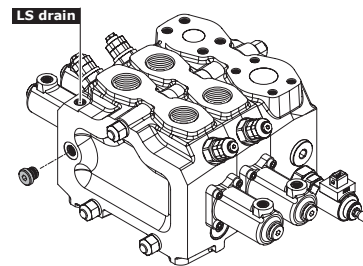

## F - Electrohydraulic with external LS end-rear drain

Note:  
Electrohydraulic end cover sections include components A and B as well as two (2) solenoid pilot valves.

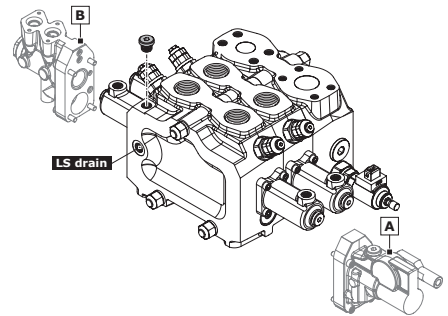
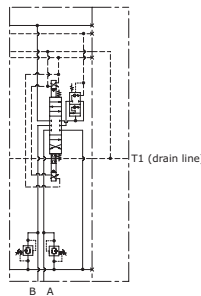

## G - Electrohydraulic with external LS drain on top

Note:  
Electrohydraulic end cover sections include components A and B as well as two (2) solenoid pilot valves.

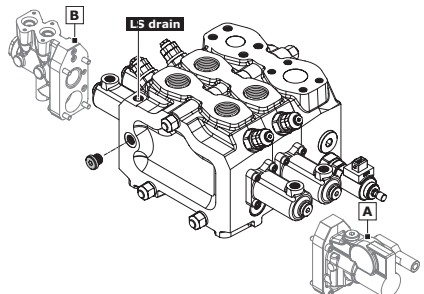
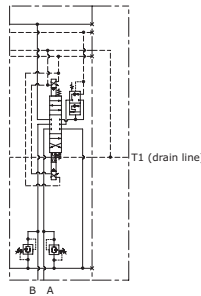

# General torque specifications

The following pictures provide the main torque specifications for the CLS250. The three drawings depict the inlet section, the working section and the end cover plate.

## Inlet section

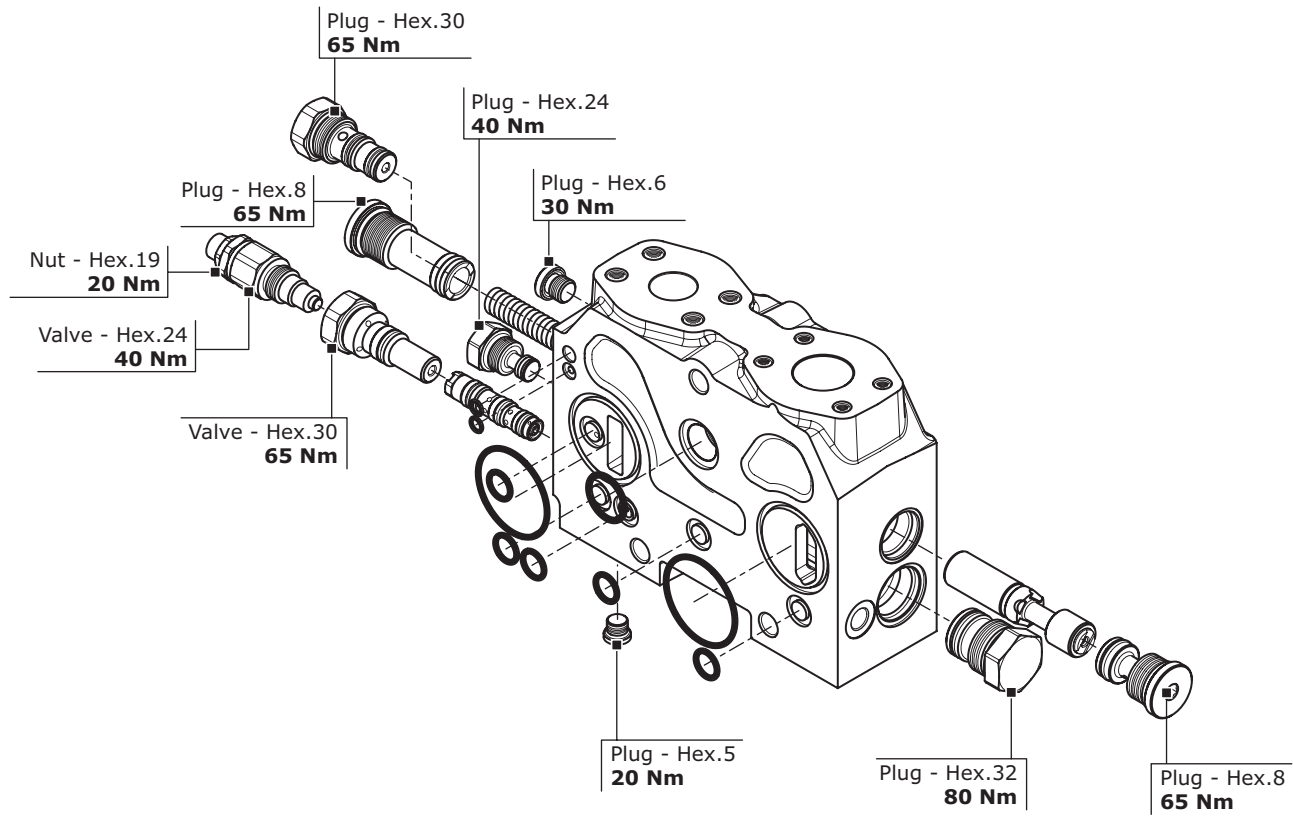

# General torque specifications

The following pictures provide the main torque specifications for the CLS250. The three drawings depict the inlet section, the working section and the end cover plate.

## Valve section

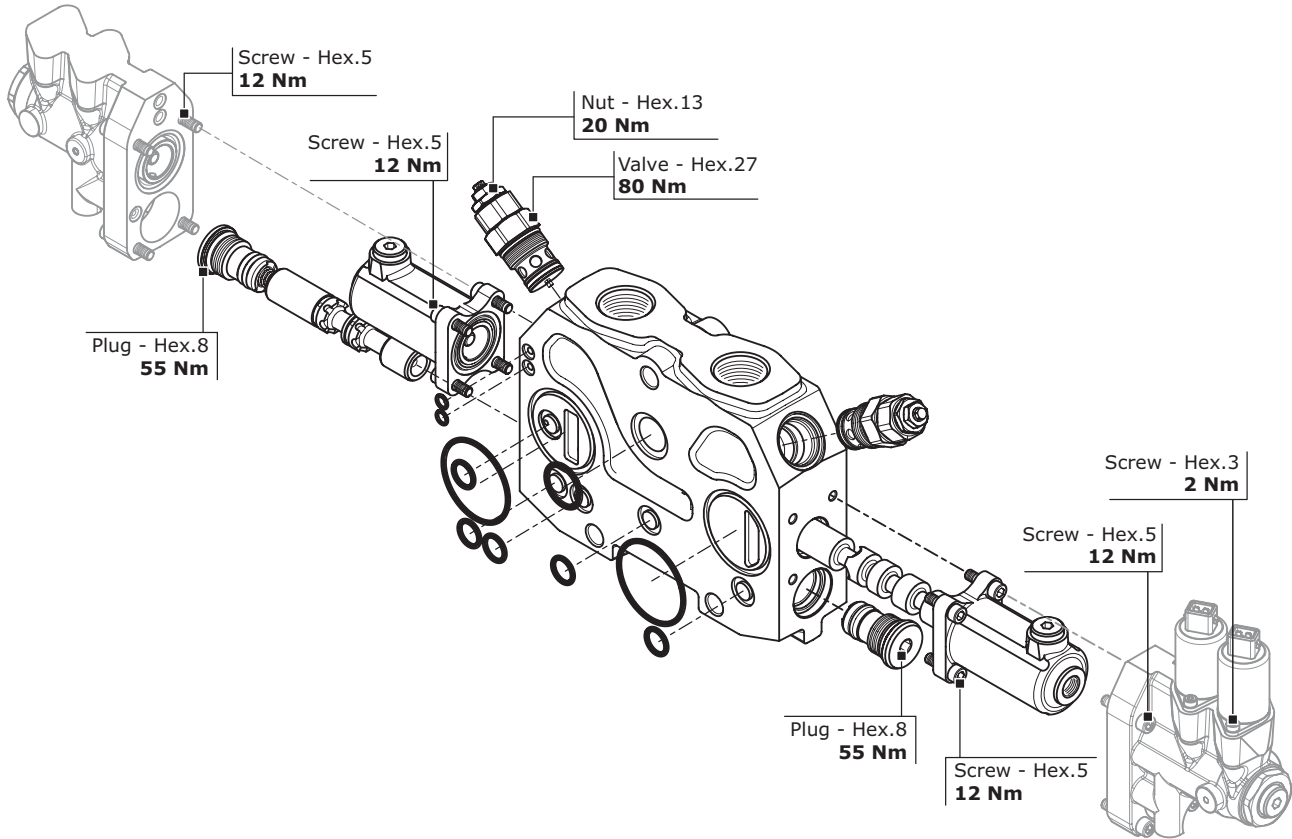

## End cover section

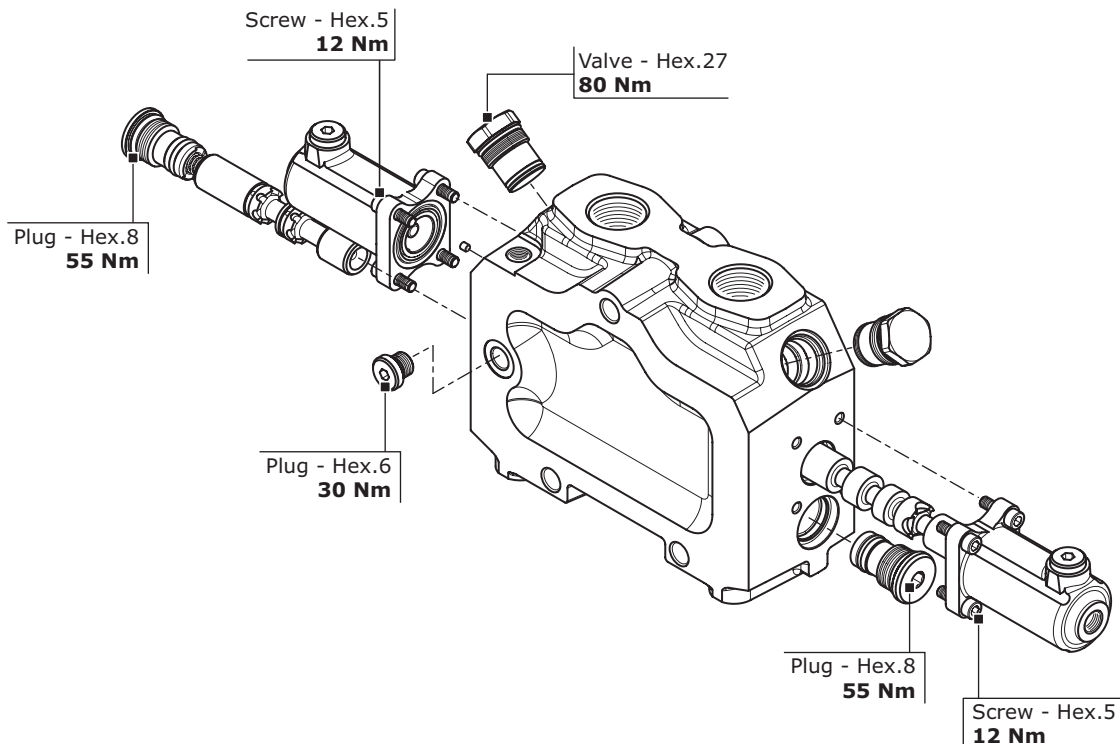

# Hydraulic fluid recommendations

## Introduction

Oil in hydraulic systems performs the dual function of lubrication and transmission of power. It is a vital element in a hydraulic system, and careful selection should be made with the assistance of a reputable supplier. Proper selection of oil assures satisfactory life and operation of system components, especially hydraulic pumps and motors.

Generally, oil selected for use with pumps and motors is acceptable for use with valves. Critical servo valves may need special consideration.

When selecting oil for use in an industrial hydraulic system, be sure the oil:

- Contains the necessary additives to ensure excellent anti-wear characteristics
- Has proper viscosity to maintain adequate sealing and lubrication at the expected operating temperature of the hydraulic system
- Includes rust and oxidation inhibitors for satisfactory system operation

## Types of hydraulic fluids

Hydraulic fluids are classified by the type of base stock used. Some fluids are further classified by fluid formulation and performance.

### Anti-wear hydraulic fluids

For general hydraulic service, Eaton recommends the use of mineral base anti-wear (AW) hydraulic oils meeting Eaton specification E-FDGN-TB002-E.

Eaton requests that fluid suppliers test newly developed lubricants on Eaton 35VQ25A high pressure vane pump, according to Eaton ATS-373 test procedure, ASTM D

6973 test method and meet other requirements of the Eaton specification E-FDGN-TB002- E. Lubricants meeting the Eaton specification are considered good quality anti-wear hydraulic fluids that can be used with Eaton components at maximum allowable operating conditions. They offer superior protection against pump wear and long service life.

### Crank case oils

Automotive-type crankcase oils with American Petroleum Institute (API) letter designation SE, SF, SG, SH or higher per SAE J183 classes of oils are recommended for hydraulic service. The "detergent" additive tends to hold water in a tight emulsion and prevents separation of water.

Automotive type crankcase oils generally exhibit less shear stability, which can result in higher loss of viscosity during service life.

Multiple-viscosity, industrial grade hydraulic fluids with better shear stability will provide improved viscosity control. Other mineral oil based lubricants commonly used in hydraulic systems are automatic transmission fluids (ATFs) and universal tractor transmission oils (UTTOs).

### Synthetic hydrocarbon

Synthetic hydrocarbon base stocks, such as polyalphaolefins (PAOs), are also used to formulate AW hydraulic fluids, crankcase oils, ATFs and UTTOs.

### Synthetic hydrocarbon

Synthetic hydrocarbon base stocks, such as polyalphaolefins (PAOs), are also used to formulate AW hydraulic fluids, crankcase oils, ATFs and UTTOs.

### Environmentally friendly hydraulic fluids

Eco-friendly characteristics is becoming a critical need, and a number of biodegradable hydraulic fluids are being used more and more in environmentally sensitive areas.

Biodegradable hydraulic fluids are generally classified as vegetable oil based (HETG), synthetic ester (HEES), polyalkylene glycol (HEPG) and polyalphaolefin (HEPR). In addition, special water glycol hydraulic fluids are used in applications in which water miscibility is necessary, along with biodegradable properties.

### Fire-resistant hydraulic fluids

Fire-resistant fluids are classified as water containing fluids or synthetic anhydrous fluids. Water acts as the fire retarding agent in water containing fluids. The chemical structure of synthetic anhydrous fluids provides fire resistance.

Many applications that are prone to fire hazard, such as steel mills, foundries, die casting, mines, etc., require the use of fire resistant hydraulic fluid for improved fire safety. Fire resistant fluids may not be fireproof, but they have better fire resistance compared to mineral oil.

The alternative fluids are recommended when specific properties, such as fire resistance, biodegradability etc., are necessary for the application. Keep in mind that alternative fluids may differ from AW petroleum fluids in properties such as pressure viscosity coefficient, specific gravity, lubricity etc. Hence certain pumps / motors may need to be de-rated, some can be operated under full ratings and others are not

rated. Be sure to confirm product ratings with the specific fluid in the intended application.

### Viscosity

Viscosity is the measure of a selection of hydraulic fluid with a specific viscosity range should be based on the needs of the system, limitations of critical components, or proper performance of specific types of units. At system startup and during operation, Eaton recommends maintaining the fluid's maximum and minimum viscosity ranges (see chart). Very high viscosities at startup temperatures can cause noise and cavitation damage to pumps.

Continuous operation at moderately high viscosities will tend to hold air in suspension in the fluid, as well as generate higher operating temperatures. This can cause noise, early failure of pumps and motors and erosion of valves. Low viscosities result in decreased system efficiency and impairment of dynamic lubrication, causing wear.

It is important to choose the proper fluid viscosity for your particular system in order to achieve the startup viscosity and running viscosity range (see chart) over the entire temperature range encountered. Confirm with your fluid supplier that the fluid viscosity will not be less than the minimum recommended at the maximum fluid temperature of your application.

A number of anti-wear hydraulic fluids containing polymeric thickeners (Viscosity Index Improvers [VII]) are available for use in low temperature applications. Temporary or permanent viscosity loss of some of these fluids

# Hydraulic fluid recommendations

at operating temperature may adversely affect the life and performance of components. Before using polymer containing fluids, check the extent of viscosity loss (shear stability) to avoid hydraulic service below the recommended minimum viscosity. A fluid with good shear stability is recommended for low temperature applications.

Multi-grade engine oils, ATFs, UTTOs etc., also contain VIs, and viscosity loss will be encountered during use.

## Cleanliness

Fluid cleanliness is extremely important in hydraulic systems. More than 70% of all failures are caused by contamination, which can reduce hydraulic system efficiency up to 20% before system malfunction may be recognized. Different hydraulic components require different cleanliness levels. The cleanliness of a hydraulic system is dictated by the cleanliness requirement of the most stringent component in the system. OEMs and distributors should provide their customers with cleanliness requirements for Eaton hydraulic components used in their system designs. Refer to Eaton product catalogs for specific cleanliness requirements of individual components.

## Fluid maintenance

The condition of a fluid has a direct bearing on the performance and reliability of the system. Maintaining proper fluid viscosity, cleanliness level, water content, and additive level is essential for excellent hydraulic system performance. In order to maintain a healthy fluid, Eaton recommends performing periodic checks on the condition of the fluid.

## System design considerations

When designing a hydraulic system, the specific gravity of the hydraulic fluid needs to be taken into consideration. If the specific gravity of the fluid is higher than that of mineral oil, be sure the reservoir fluid level is adequately above the pump inlet to meet the recommended inlet operating condition of minimum 1.0 bar absolute pressure at the pump inlet.

## Filters

Proper filter type and size, which vary depending on the type of fluid used in a system, are essential for healthy system function. The primary types of filter materials are paper, cellulose, synthetic fiber, and metal.

Filter media, adhesive, and seals must be compatible with the fluid used in the system. To lengthen fluid change out intervals, special absorbent filter media may be used to remove moisture and acids from phosphate esters.

## Seals/elastomers

Select seal/elastomer materials that are suitable for the application, minimum and maximum operating temperature, and compatibility with the type of fluid used in the hydraulic system. The effect of hydraulic fluid on a particular elastomer depends on the constituents of the fluid, temperature range, and level of contaminants.

## Replacing hydraulic fluid

Although sometimes valid, arbitrary hydraulic fluid change-outs can result in wasting good fluid and unnecessary machine downtime.

A regularly scheduled oil analysis program is recommended to determine when fluid should be replaced. The program should include inspection of the fluid's color, odor, water content, solid contaminants, wear metals, additive elements, and oxidation products. Clean the system thoroughly and flush with

fresh, new fluid to avoid any contamination with the previous fluid/lubricant. Replace all seals and filters with new, compatible parts. Mixing two different fluids in the same system is not recommended.

Contact your Eaton representative with questions concerning hydraulic fluid recommendations.

# Viscosity requirements

Product Line	Minimum	Optimum Range	Maximum Allowed - Startup	Cleanliness Requirement (ISO 4406:99)
CMX, CML, and CLS proportional control valves	6 cSt (45 SUS)	20-43 cSt (100-200 SUS)	2158 cSt (10,000 SUS)	18/16/14

Eaton  
Hydraulics Group USA  
14615 Lone Oak Road  
Eden Prairie, MN 55344  
USA  
Tel: 952-937-9800  
Fax: 952-294-7722  
[www.eaton.com/hydraulics](http://www.eaton.com/hydraulics)

Eaton  
Hydraulics Group Europe  
Route de la Longeraie 7  
1110 Morges  
Switzerland  
Tel: +41 (0) 21 811 4600  
Fax: +41 (0) 21 811 4601

Eaton  
Hydraulics Group Asia Pacific  
Eaton Building  
4th Floor, No. 3 Lane 280 Linhong Rd.  
Changning District  
Shanghai 200335  
China  
Tel: (+86 21) 5200 0099  
Fax: (+86 21) 5200 0400