

HPC10-J48 HyPerformance™ Piloted Directional

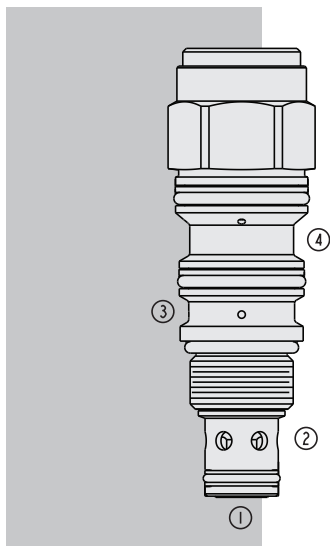

DESCRIPTION

A high pressure, two-way, bi-directional, pilot-to-open, balanced poppet-type, screw-in, cartridge-style, hydraulic directional element designed to function as a load-holding or blocking valve in applications requiring low internal leakage.

OPERATION

In the unpiloted state, the **HPC10-J48** blocks flow from 1 to 2 bi-directionally. On remote pilot signal at port 3, the valve shifts to allow flow from ports 1 to 2 bi-directionally. The spring chamber is vented to port 4. Pressure at port 4 will directly affect the pilot pressure required to shift the valve and must be added. The hydraulically balanced poppet will allow ports 1 and 2 to be fully pressurized without affecting required pilot pressure to actuate the valve. With port 4 vented, the valve will fully shift with a minimum pilot pressure of 17 bar (250 psi).

FEATURES

- Bi-directional flow.
- Balanced poppet.
- Low internal leakage.
- All HyPerformance products are tested to the rigorous standards of NFPA specification T2.6.1.
- All HyPerformance products are tested at a verification level of 90% and an assurance of 99%.

ISO SYMBOL

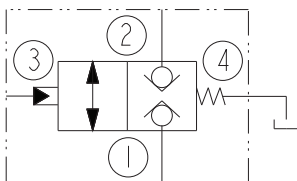

PERFORMANCE (Cartridge Only)

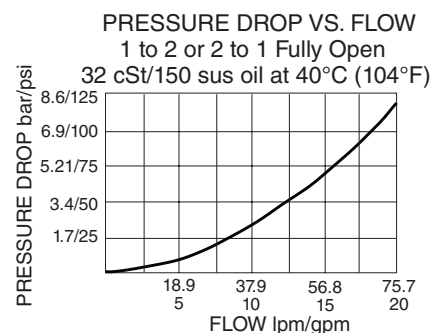

RATINGS

Operating Pressure: Ports 1 & 2 (work ports): 350 bar (5075 psi); 10% cycle life: 420 bar (6090 psi); Port 3 (pilot): 207 bar (3000 psi); Port 4 (tank): 69 bar (1000 psi)

Proof Pressure: 690 bar (10000 psi)

Burst Pressure: 1380 bar (20000 psi)

Flow Rating: 76 lpm (20 gpm)

Internal Leakage: 10 drops/min between ports 1 and 2 at 35 bar (500 psi) and 350 bar (5075 psi)

Cycle Life: Two million cycles (900K cycles at 350 bar and 100K at 420 bar in each flow direction)

Temperature: -40 to 100°C (-40 to 212°F) with Buna seals;

-26 to 204°C (-15 to 400°F) with fluorocarbon seals;

-54°C to 107°C (-65°F to 225°F) with urethane seals

Filtration: See page 9.010.1

Fluids: Mineral-based or synthetics with lubricating properties at viscosities of 7.4 to 420 cSt (50 to 2000 sus); See Temperature and Oil Viscosity, page 9.060.1

Installation: No restrictions; See page 9.020.1

Cavity: HVC10-J4; See page 9.110.1

Cavity Tool: HCT10-J4XX; See page 8.600.1

Seal Kits: SK10-J4N-BBM (Buna N); SK10-J4V-BBM (fluorocarbon); SK10-J4U-000 (urethane); See page 8.650.1

Element, Balanced Poppet, NC

HPC10-J48

DIMENSIONS

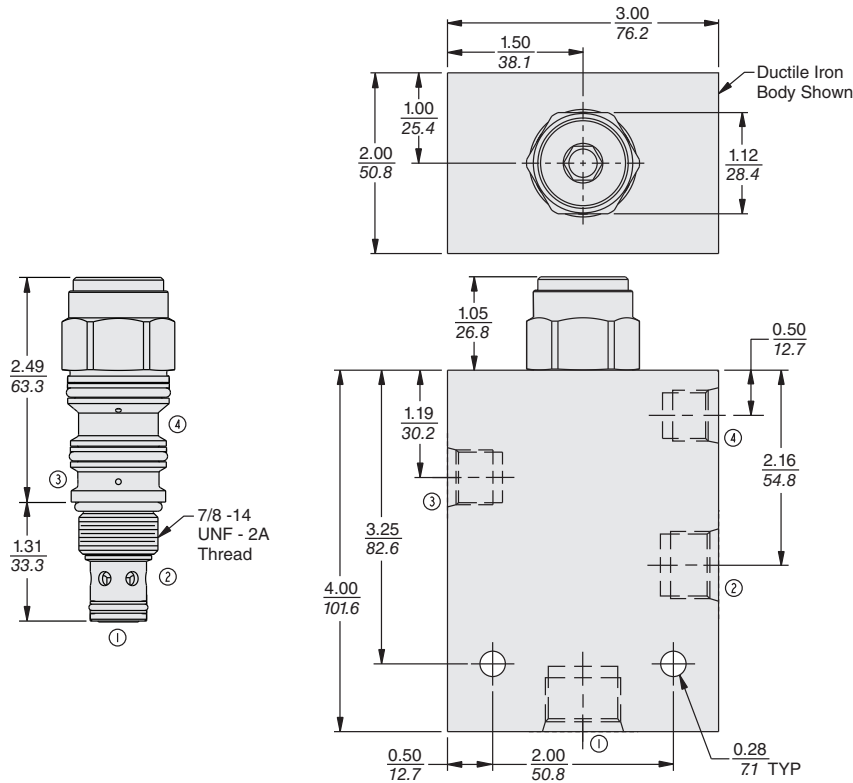

MATERIALS

Cartridge: Weight: 0.3 kg (0.65 lb)
Steel with hardened work surfaces. Zinc-nickel plated exposed surfaces. PPDI urethane seals without back-up rings standard. Buna N and fluorocarbon seals also available.

Standard Ported Body:
Weight: 2.3 kg (5.2 lb)
H-series ductile iron standard.
Rated to 345 bar (5000 psi)
See page 8.010.1

TO ORDER

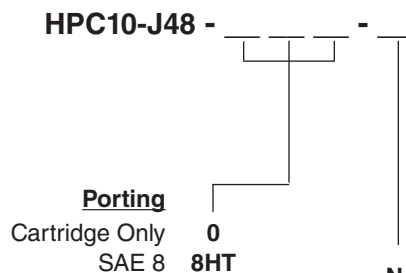

Seals
N Buna N
V Fluorocarbon
*** U** PPDI Urethane
* Urethane seals recommended for operating pressures above 241 bar (3500 psi).