

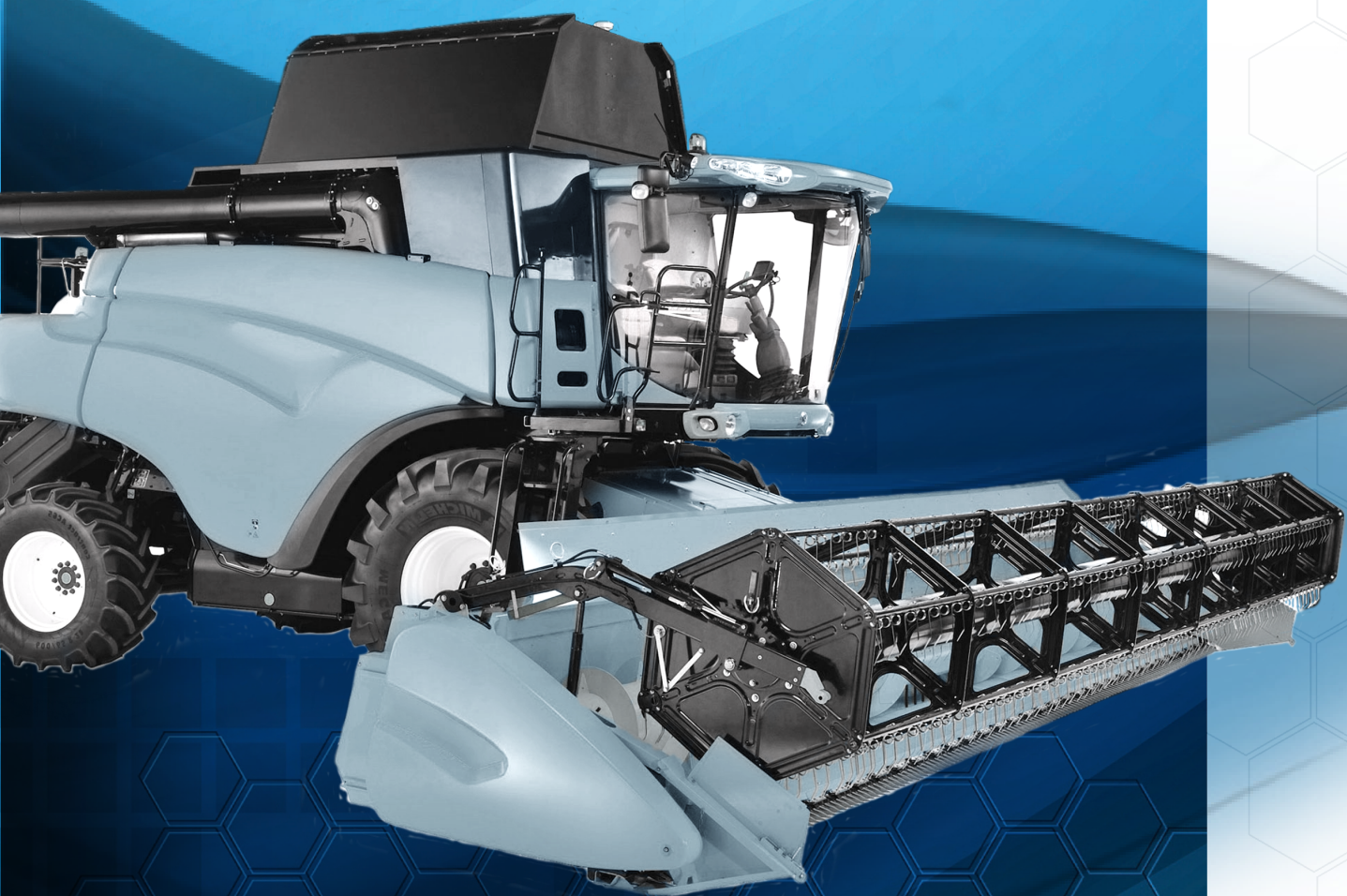

Harvester Solutions



www.hydraforce.com

Suspension

Cab

Spreader

Axle

Auto Steering

Track

Feeder

Header

TECHNOLOGY AND HARVESTERS

HydraForce technology is increasing productivity of harvesting machines around the world. Precise and responsive control of cutting, chopping, shaking, sorting, rotating, spreading, conveying, brushing, raising and lowering is made possible with our comprehensive line of cartridge valves, custom manifolds, and high performance electronic controls.

Our electrohydraulic control solutions can help you deliver the highest yields of quality crop from any field, vineyard, or orchard.

Innovative, custom-tailored control solutions provide a competitive advantage for agricultural equipment in the harvesting sector. Here are some of the many ways HydraForce controls can enhance your hydraulic equipment. ***It's what we do every day.***

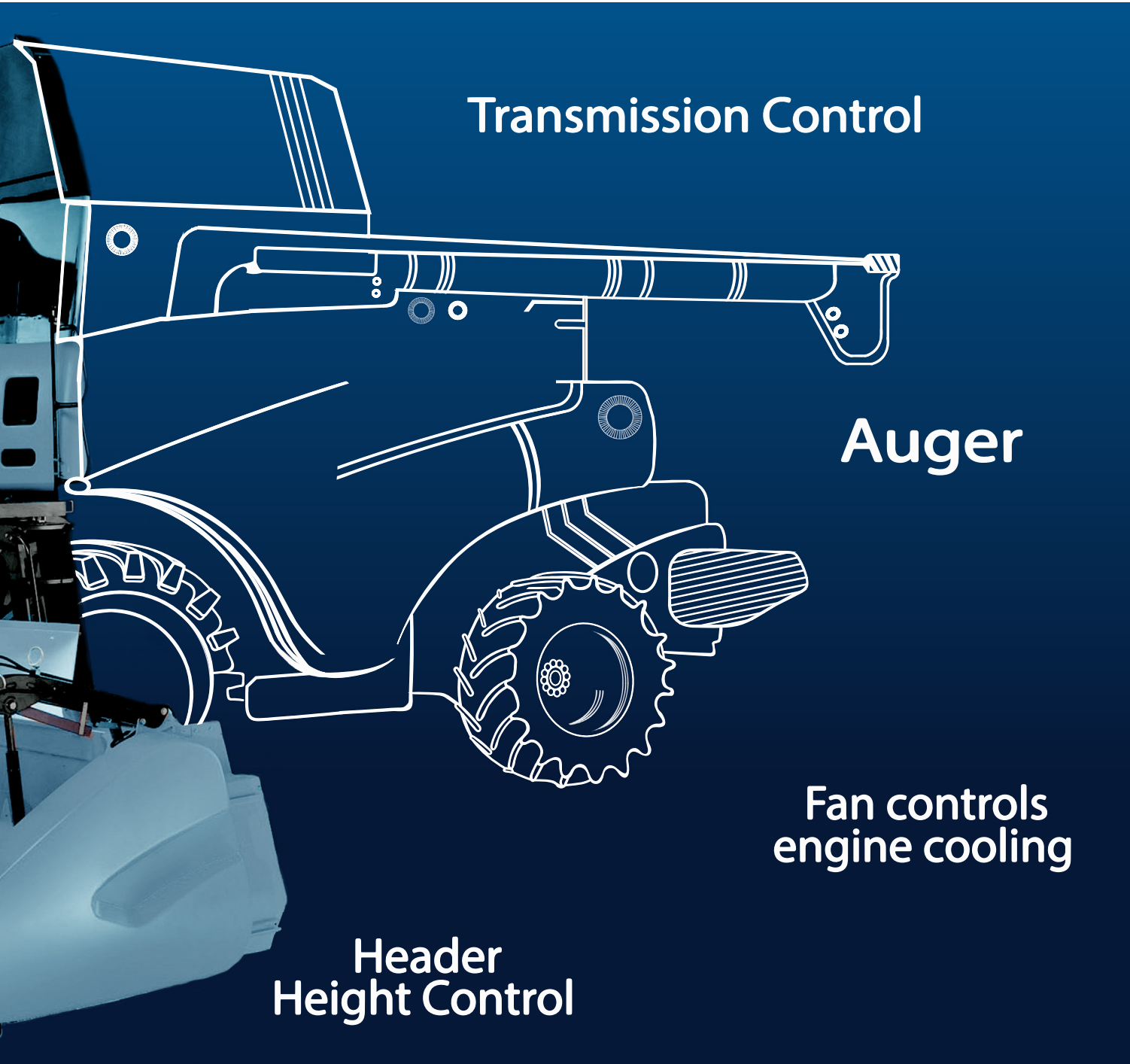

Transmission Control

Auger

Fan controls
engine cooling

Header
Height Control

CONTENTS

Combine Harvesters	Pages 4-5
Suspension, Powertrain, Fan Control	Pages 6-7
Cotton Harvesters	Page 8
Balers, Rice Harvesters, Digging Harvesters	Page 9
Sugarcane Harvesters	Page 10
Tree Shaking Harvesters	Page 11
Our Breadth of Product	Page 12
Electronic Controls	Page 13
The HydraForce Story	Page 14

THE HYDRAFORCE DIFFERENCE

- Highest quality guaranteed
- Speed to market
- Flexible and responsive
- Over 600 combined years of cartridge development experience
- Integration of electronic and hydraulic technologies

COMBINE HARVESTING

HydraForce takes a full systems approach when solving harvesting equipment control challenges. Our wide range of technology allows us to quickly find simple solutions as well as manage the intricacies of a more complex control scheme that might involve custom electronic controls or the integration of hydraulics with engine management or global positioning technologies. From header to spreader, this design flexibility is the key to a competitive advantage in the marketplace.

MAIN CONTROL

Crop harvesting depends on equipment that can combine the functions of reaping, threshing and winnowing, or separating the grain from the chaff. Today's combine harvesters have become more versatile than ever, with removable headers to handle different grains, suspension and leveling systems to scale terrain, continuously variable transmissions that make efficient use of fuel and fan drives that provide engine cooling or crop cleaning.

The main control for a combine consolidates all harvesting functions the chaff spreader, reel drive, auger swing, feeder - reverser, reel raise/lower and reel fore/aft - ensuring efficient use of available horsepower.

A new function can be added without affecting existing functions, allowing the opportunity for additional dealer-installed options after the combine leaves the factory. Applying our broad range of logic elements can resolve common system issues, such as pressure spikes and unstable or erratic operation.

HEADER CONTROL

HydraForce has a line of high-pressure, multi-function valves with integrated compensators and load sense capabilities to accomplish smooth and responsive raising/lowering and tilting of the combine header.

For smooth, steady speed rotary motion control for reel-type headers, HydraForce offers a new torque control solution that can outperform conventional flow controls for this type of application.

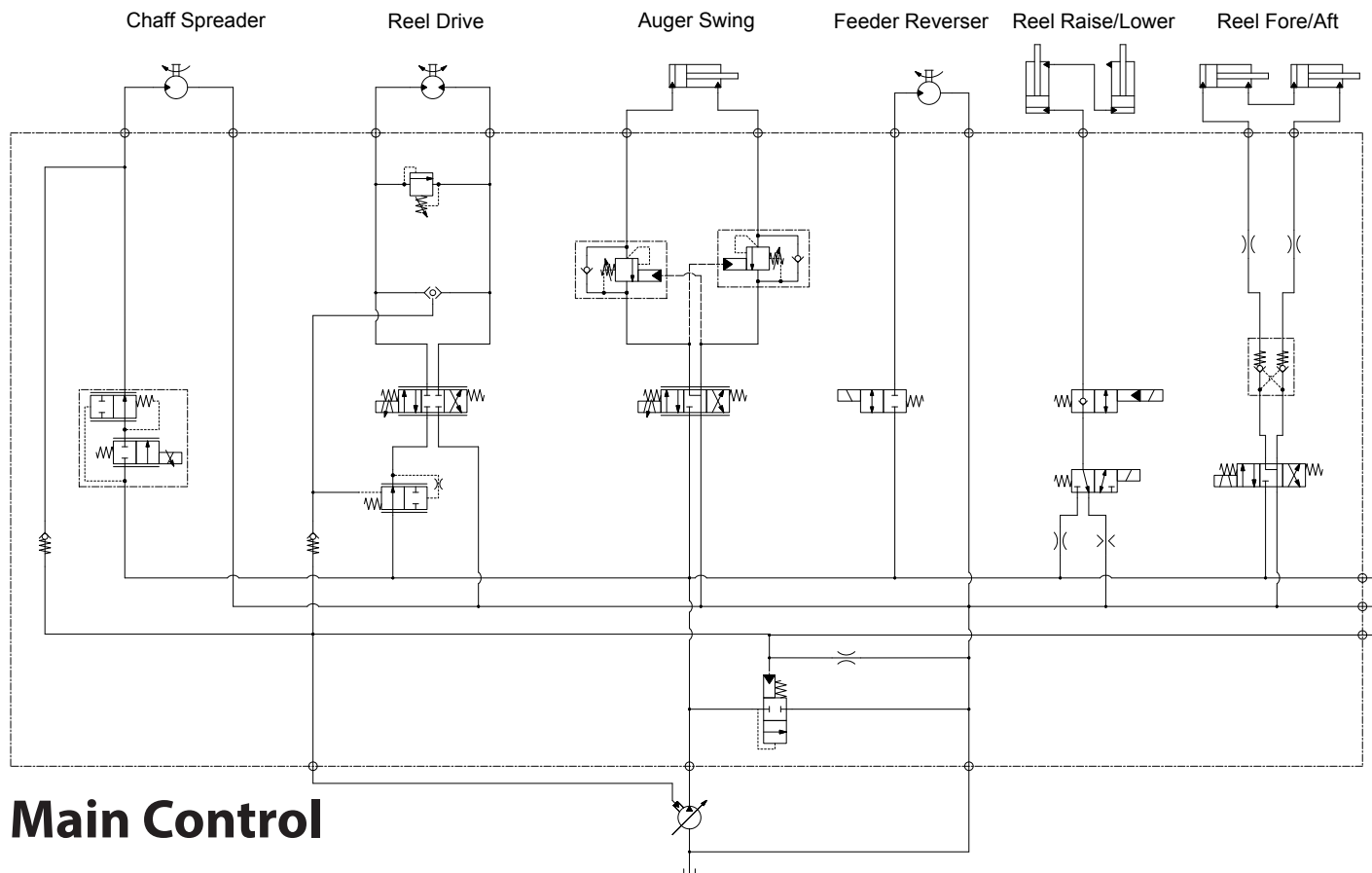

TORQUE CONTROL

The HydraForce constant torque control maintains pressure in the circuit by limiting the torque applied to the rotating load, rather than controlling flow with a throttling valve. For systems with a fixed displacement pump, this is done with a proportional relief valve. For systems with a variable displacement, load-sensing pump, a proportional pressure reducing/relieving valve is used.

For better tuning of control response, you can add an ECDR electronic controller and hall effect speed pickup to the circuit to achieve closed-loop PID control.

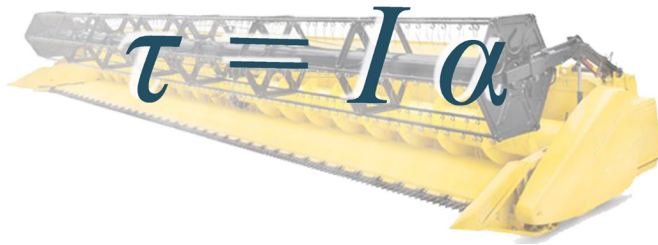

“HydraForce takes a full systems approach when solving equipment control challenges.”

rates to choose from, the HSPEC valve offers design flexibility for proper control of position and pressure while harvesting or during transport. HSPECxx-30 valves have a built-in post-compensator, enabling more compact and efficient directional control packages.

MULTI-FUNCTION COMPENSATOR VALVES

The HydraForce HSPEC family of multi-function cartridge valves ensures scalable flow capacity and precise control for any combine attachment. With three sizes and flow

HSPECxx-34 valves combine a proportional lowering valve with a pressure compensator and are ideal for lifting and lowering control of single-acting cylinders. When combined with the HSPECxx-30 valves, you can create a compact, cost-effective flow-sharing circuit that enables efficient use of available horsepower while offering controlled load lowering.

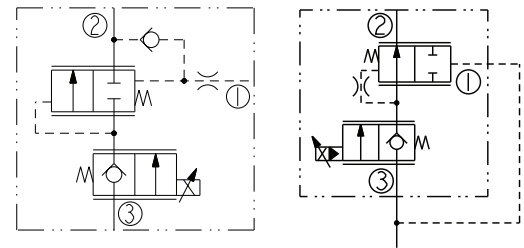
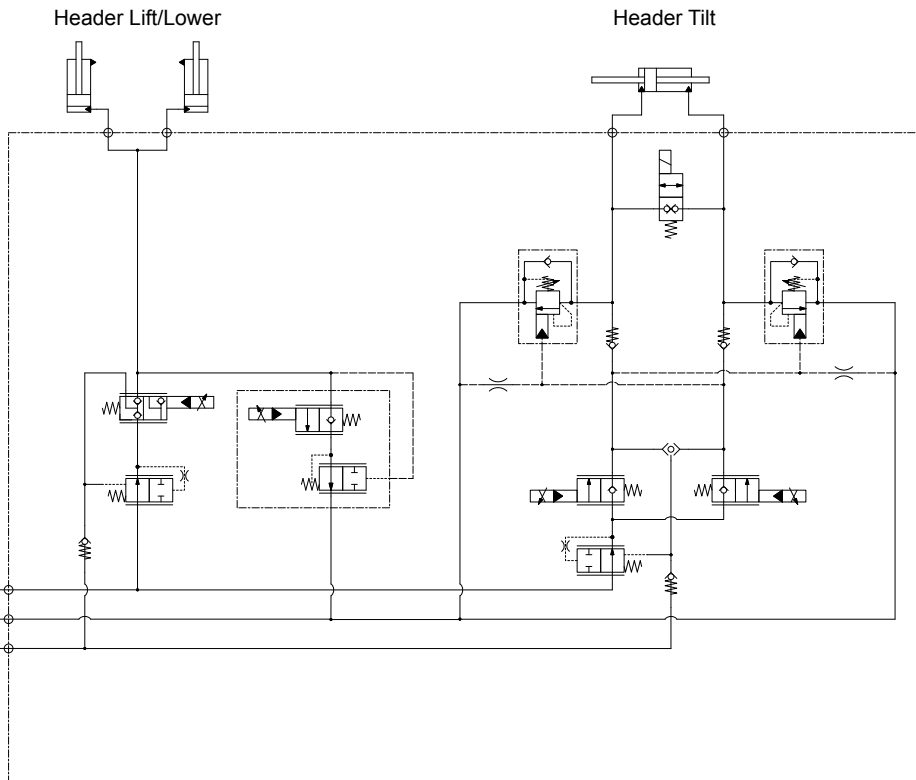

Header Control

SUSPENSION

Cartridge valving and manifolds are used extensively in axle, cabin, header and even track suspension systems.

Track Suspension - Rice and other crops in wet or muddy fields are harvested more effectively by combines with tracks that distribute weight evenly across a field instead of wheels that are likely to get stuck. Track systems use compact, efficient, and responsive cartridge valving for the suspension.

Header Suspension - During transportation mode the header suspension system isolates the header from the rest of the machine. It allows the header to move and prevents the header oscillations from causing instability in the rest of the system.

HydraForce custom header ride control solutions can be integrated into the header height control manifold, or designed as a stand alone system.

The following options are available:

- Stand-alone or integrated
- Flow rates up to 260 lpm (70 gpm)
- Dynamic or passive systems
-

BASIC SUSPENSION

This basic hydro-pneumatic suspension system is ideal for cabin or seat suspension.

- Single or double acting cylinder
- Accumulator
- Level control manifold
- Cartridge valves
- Pressure ratio 1:3 between min and max loaded axle

ADVANCED SUSPENSION

Traveling over rough or uneven ground is typical for harvesters. When there is a high variance between minimum and maximum axle load, a more sophisticated axle suspension system is required, with a spring rate that adjusts continuously to driving speed, acceleration, and terrain.

- Single or double-acting system
- Independent accumulators for piston/rod side
- Constant or variable pressure on rod side
- Variable damping
- Integral sensors
- Software development

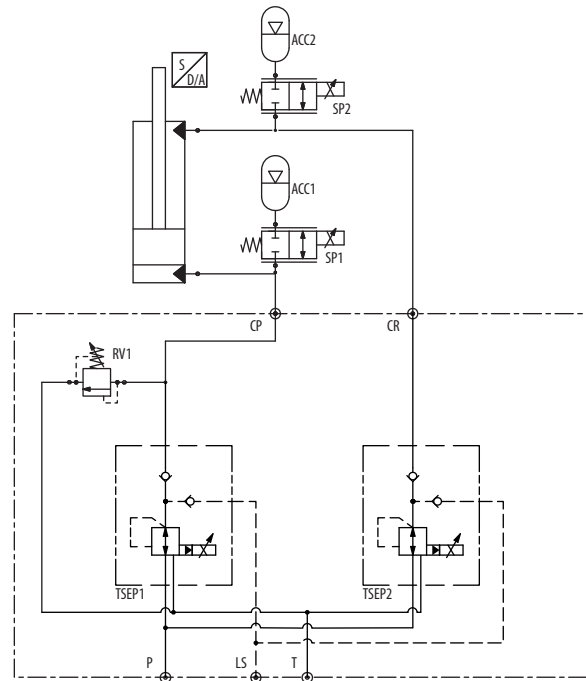

“HydraForce custom header ride control solutions can be integrated into the header height control manifold, or designed as a stand alone system.”

POWERTRAIN

The flexibility of cartridge valving is demonstrated in a multi-speed transmission circuit that provides the full range of control possibilities. On/off clutch control, four-wheel drive and park brake engagement, and gear shifting can all be orchestrated with a mix of electroproportional valves, solenoid valves, and piloted spool-type directional elements.

The electro-proportional pressure control valve is used to precisely ramp and engage the clutch packs for the smoothest possible shifting experience. The EPxx-S35 line of valves are very stable, high flow, pressure regulators used to provide oil to the valves that control the transmission's clutch packs and the torque converter.

Usually there is a state in transmission gearing when the use of clutches are mutually exclusive. In this example, the 3rd gear and reverse are never engaged at the same time. Here you can use a solenoid valve to allow a single proportional pressure control valve to control either clutch pack. This saves money by eliminating a proportional output and valve.

Drop-in solenoid valves provide a reliable and cost-effective method for controlling on / off pressure to accessories, such as parking brakes and differential locks.

FAN CONTROL

Fan drives controlled by hydraulic cartridge valves can adjust speed based on cooling demand, so they run on less horsepower than mechanical fan drives, providing greater fuel economy for combines.

Control valves with multiple temperature inputs can be used to provide variable fan speed control depending on air temperature, load, and cooling requirements. If the radiator gets clogged, two-position, four-way solenoid valves can automatically reverse fan direction.

- Flow rates up to 190 lpm (50 gpm)
- Fail safe high or low
- Preconfigured controls available
- Reduce horsepower consumption by up to 30%

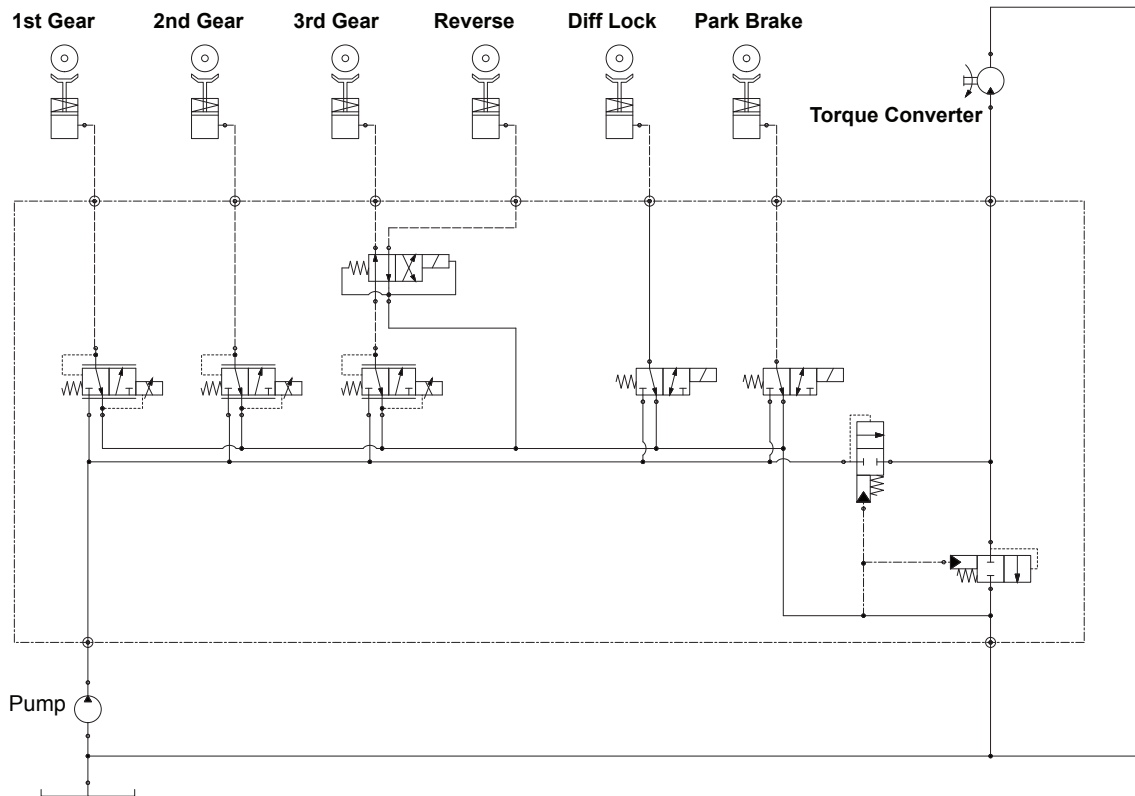
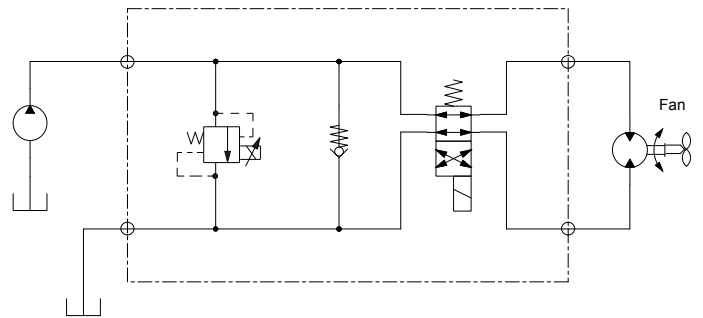

COTTON HARVESTERS

HydraForce has extensive experience developing main control manifolds for cotton harvesters including picking, conveying, baling, wrapping functions and proportional fan control that conserves energy when cleaning a light cotton crop and increases fan speed when handling a heavy cotton crop.

Proportional controls are attractive to the cotton harvesting market with its multitude of machine functions. Whether picking, stripping, or baling, efficient hydraulic control is the best solution for getting the highest yield from the field.

Proportional controls can conserve flow or pressure when harvesting or handling a light crop, and increase it for a heavy crop. This ability to adapt to dynamic load conditions also saves fuel.

HydraForce is the leader in electro proportional controls, with 2-, 3-, 4- and 5-way models for flow or directional control, with reducing/relieving, bidirectional, pressure-compensated, and load-sensing solutions.

Cotton harvesters rely on cartridge valving for efficient control of the picking and cotton stripping operations.

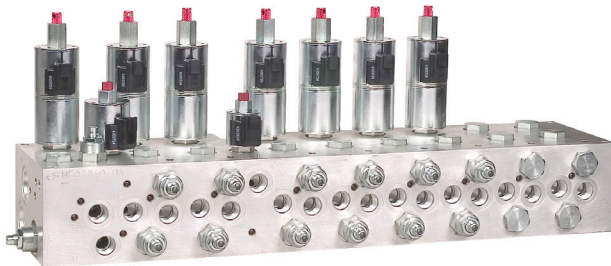

“HydraForce has extensive experience developing main control manifolds.”

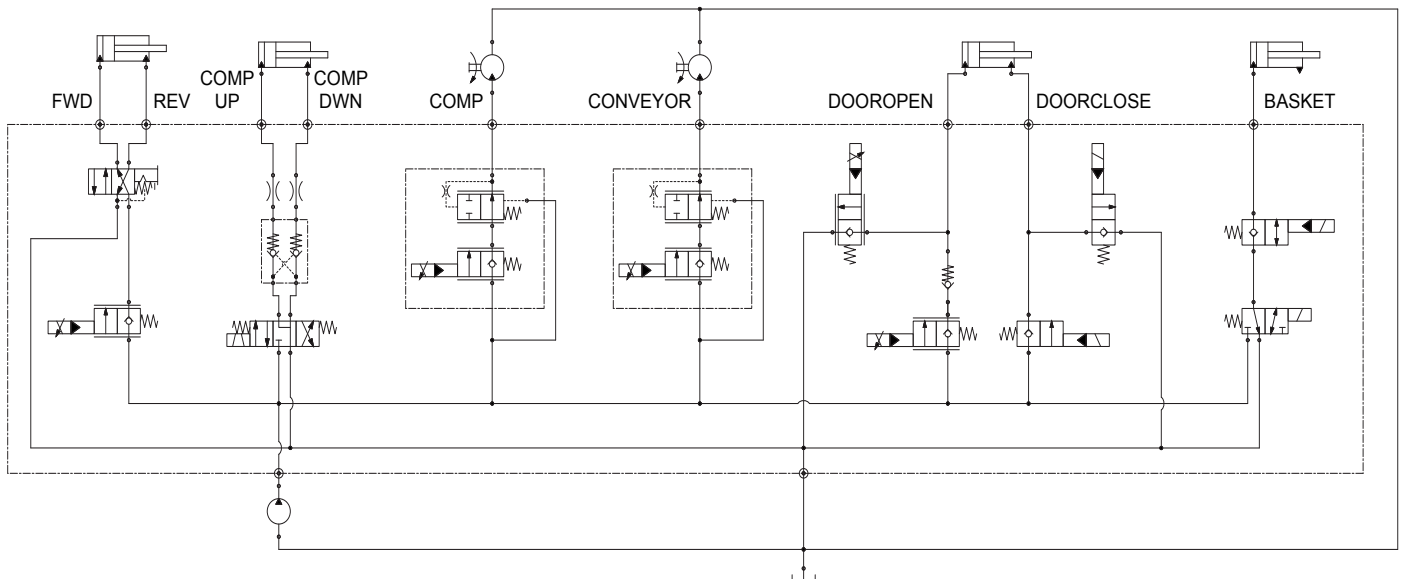

BALERS

Heavy bales of hay have a heavy reliance on hydraulics for compacting, wrapping and cutting. Our electrohydraulic solutions can provide fine control of hydraulically operated bale handling.

Proportional hydraulic control of the mechanisms for binding and wrapping bales is accomplished effectively with cartridge valves. Accurate proportional pressure control can ensure the correct bale density – soft in the center to allow enough air flow for drying, and hard on the outside to shed water.

“Our electrohydraulic solutions can provide fine control of hydraulically operated bale handling.”

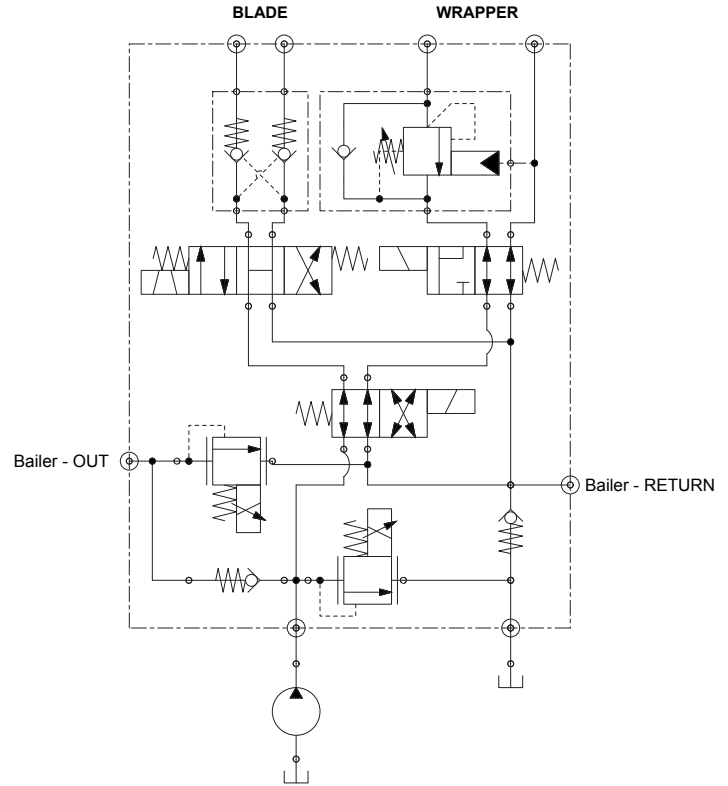

POTATO, CARROT, AND BEET HARVESTERS

Crops that grow underground, such as potatoes, carrots, and beets, require specialized harvesting equipment that trims or mows the plants first, then digs below the ground to harvest them.

Cartridge valves can provide the fine control required for these crops – whether cutting, digging, raising, lowering, or conveying. HydraForce has a solution that will perform in these demanding applications.

RICE HARVESTERS

Cartridge valves can simplify the mechanization of rice harvesting, with proportional control that improves efficiency for transmissions and fans. A variety of cartridge valves can be applied for crop handling functions, such as rice cutting, collection and separation.

The durability of HydraForce cartridge valves is a special advantage in rice field and paddies, which are typically wet or muddy.



SUGARCANE HARVESTERS

Sugarcane is the world's largest crop and one of the toughest to harvest. It grows in the heat and humidity of tropical countries and can reach heights of 2 to 6 meters (6 to 19 feet). The stalks are tall and tough and must be trimmed at the top and cut at the base during harvest. Cleaner cane means higher quality and less equipment damage from debris, so extracting fans are used to blow away trash before the trimmed cane is collected. All of these functions - cutting, chopping, lifting, cooling, propulsion and suspension - must be done with high performance, high torque, high efficiency and low fuel consumption.

Sugar cane harvesters can be equipped with a variety of dealer-installed options, so their manifolds are designed with the flexibility to add cartridges and functions for the end user.

Sugar cane harvesting thrives on efficiency, since its intense operations require many high flow hydraulic circuits with logic elements. Proportional control cartridge valves provide an excellent way to achieve that efficiency.

Speed control of the elevator is another opportunity for the proportional control provided by cartridge valves. Fast speed is needed for a heavy crop and slower speed for a lighter crop. Being able to vary the speed as needed increases efficiency and extends the life of the elevator chain.

Large capacity flow controls in combination with numerous logic elements are especially useful for the sugarcane harvesting market, and HydraForce has the range of products to handle the most demanding requirements.

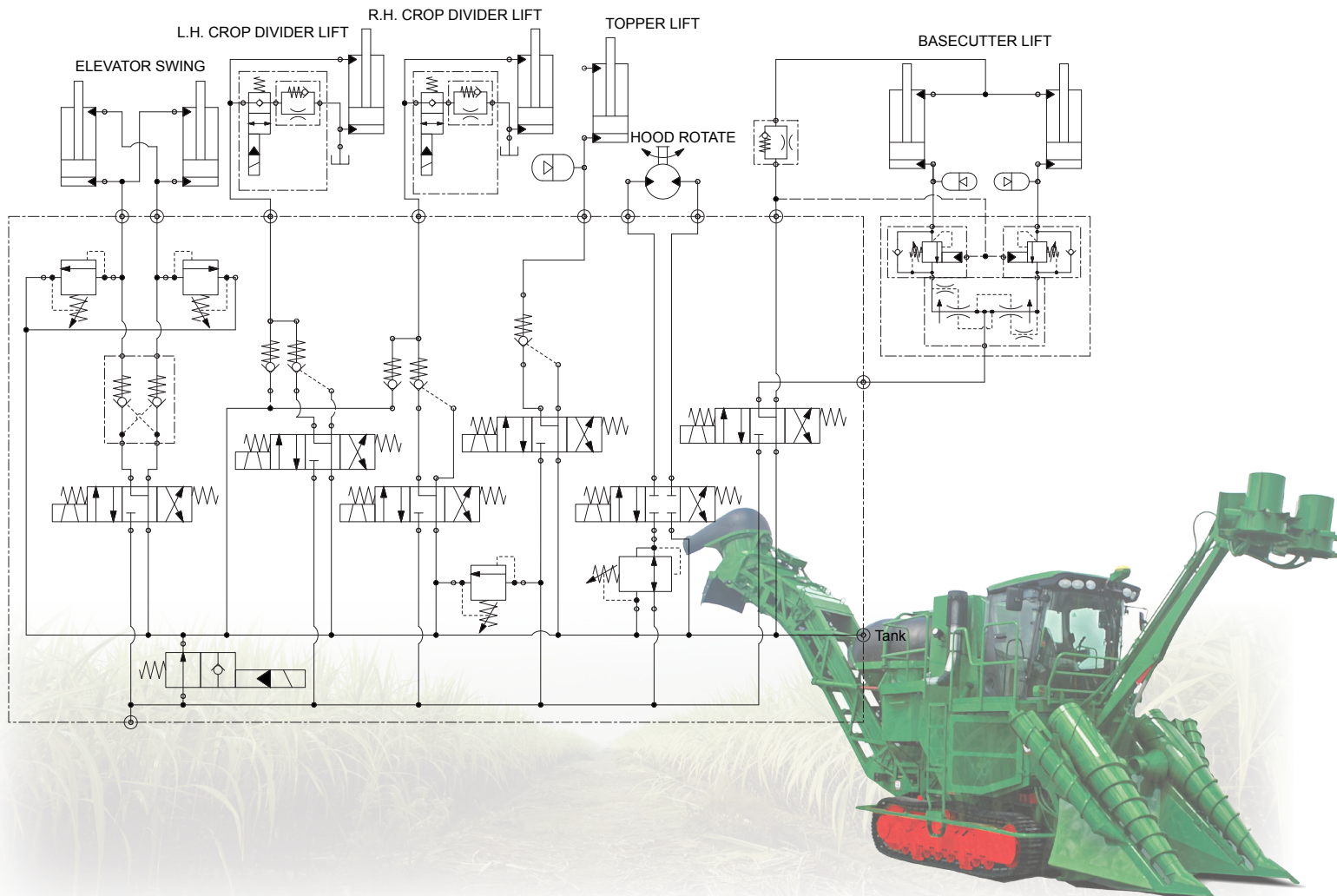

OLIVE, GRAPE, AND NUT HARVESTERS

Olives and nuts are harvested with machines that clamp to the tree and shake it. An umbrella-like collector is raised and opened to gather the crop. HydraForce can provide coordinated and smooth proportional control of the three electrohydraulic functions of clamping, shaking, and opening. Grapes, like olives, are a delicate crop that requires equipment capable of special handling and versatility. Hydraulic cartridge valves can handle the variety of controls needed on multi-function harvesting equipment that shakes the grapes off the vines, collects and conveys them, separates the leaves and stems, and prunes the vines.

SHAKER CONTROL

Accurate and stable control of shaker speed is vital to vineyard harvesting. Shake too slow and crop is left on the tree or vine. Shake too fast and the plants and supporting trellises may be damaged. In some cases, vines or trees might have bare patches, so the shaker speed may need manual adjustment. This example shaker and clamp circuit provides stable and reliable speed and pressure control of the shaker motor and clamp function as the harvester moves through the field, and is able to compensate for field conditions that can change the load demand on the motor.

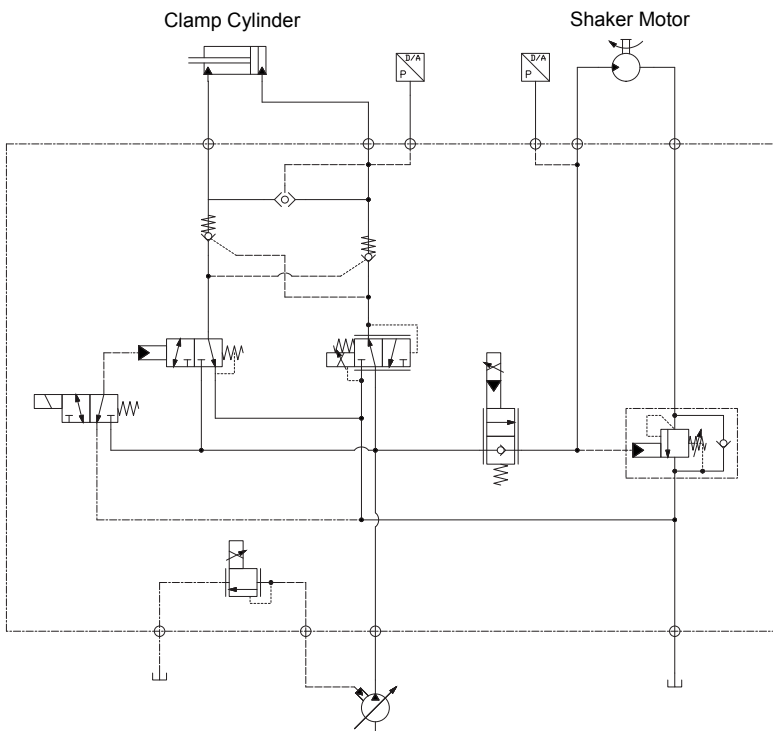

BLOWER FAN CONTROL

Fans are used by tree and vine harvesting equipment to help clean the crop, blowing away leaves and broken stems. The fan speed should be set to ensure a clean crop without wasting excess energy. The operator sets the speed of the upper and lower fans by adjusting the current supplied to the proportional pressure relief valve. Our range of low leakage solenoid and proportional valves can be applied for on/off control and variable speed control during the harvesting process.

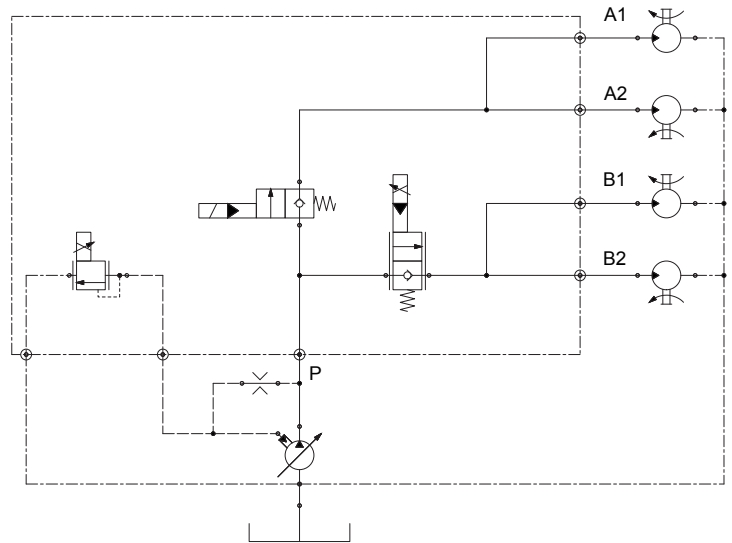

Hydraulic cartridge valves provide stable, efficient control of the shaker and cleaning fans of grape harvesting machines.

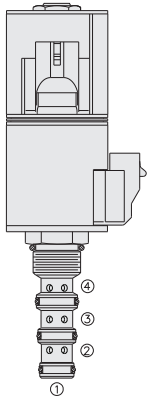

HSP10-47D
High Pressure Spool 4-Port,
3-Position, Closed Center

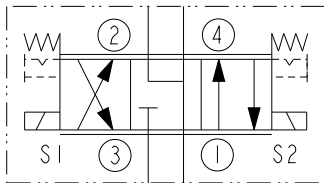

Flow: 37.9 lpm/10 gpm
Pressure: 350 bar (5075 psi)

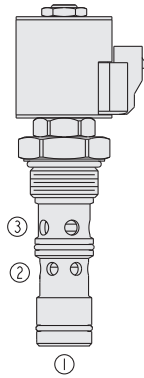

HSPECxx-30
Proportional Flow Control Valve with
Integral Compensator

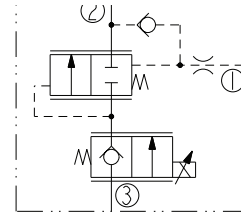

Flow: 132 lpm/35 gpm
Pressure: 350 bar (5075 psi)

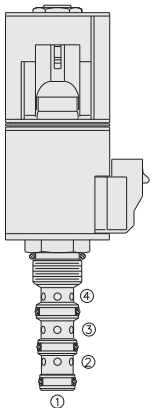

HSV10-47C
High Pressure Spool 4-Port,
3-Position, Closed Center

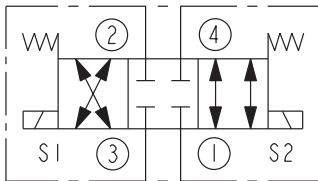

Flow: 37.9 lpm/10 gpm
Pressure: 350 bar (5075 psi)

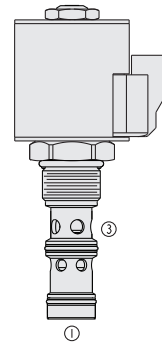

HSPECxx-34
Relief, Directing Acting Poppet with
Reverse Flow Check

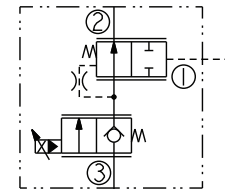

Flow: 115 lpm/30 gpm
Pressure: 420 bar (6100 psi)

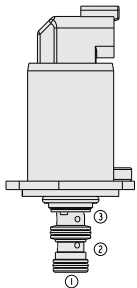

EHPR98-G3x
Proportional, Reducing / Relieving,
Drop-in

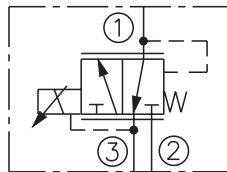

Flow: 4-6 lpm/1-4 gpm
Pressure: 20-30 bar (290-435 psi)

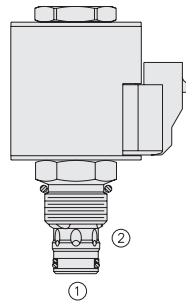

TSxx-27
Proportional Pressure Control,
Pilot-Operated Relief

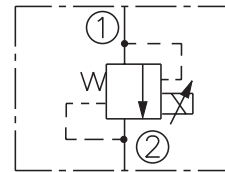

U.S. Patent
6,267,350 & 7,137,406

Flow: up to 189 lpm/50 gpm
Pressure: 241 bar (3500 psi)

OUR BREADTH OF PRODUCT

As the largest manufacturer of hydraulic cartridge valves in the world, HydraForce offers an extensive range of solenoid, electro-proportional, directional, flow, and pressure control valves. Last year, more than 200 new valves were introduced, including many high pressure and multi-function models. Cartridge valves for flow rates up to 570 lpm/150 gpm and operating pressures up to 350 bar/5,000 psi are sold individually, with housings or in manifold blocks. Valves can be custom-designed or standard product.

HydraForce designs, manufactures and supports valve, manifold and accessory products supported by heavy duty electronic machine control capabilities.

To request a free hydraulic integrated circuit (HIC) consultation, please visit:

<http://info.hydraforce.com/Free-Custom-Circuit-Consultation/>

“**HydraForce**
has more
than **600**”
standard cartridge valve products”

PROGRAMMABLE MACHINE CONTROLLERS

It's easy to add electronic control to your hydraulic application with the HydraForce line of electronic control units (ECUs) and electronic valve drivers (ExDRs).

HydraForce electronic controllers are designed to withstand the environmental demands of mobile, off-highway equipment applications. With flexible input and output configuration, these versatile controllers can easily be customized for a wide variety of applications, including fan control, generator set control, transmission and timed control applications, and more.



ExDRS-ELECTRONIC VALVE DRIVERS

ExDRs are compact, economical and reliable electronic drivers for proportional solenoid valves. They mount directly onto the solenoid coil and are configurable using *HF-Impulse* software on a computer and serial cable or CAN to USB adapter.

ExDR-0101A

One input and one output. Input can be accepted from analog or digital operator interface devices.

ExDR-0201A

One or two outputs and one input that can be accepted from analog or SAE J1939 operator interface devices.

ExDR-0203A

Feature three configurable inputs and two outputs. This larger valve driver will be able to provide precise, repeatable control of four proportional valves and one on/off solenoid. LED signal will provide quick status check.

ExDR-0506A

Features six configurable inputs and five PWM outputs.

HF-IMPULSE CONFIGURATION SOFTWARE

HydraForce has developed an easy-to-use configuration platform - *HF-Impulse*, available for free download from the HydraForce Electronics Portal at www.hydraforce.com/electronics. *HF-Impulse* allows you to flash devices with the latest firmware and configure all parameters for operation. You can configure a number of HydraForce electronic controllers using *HF-Impulse*.

ECU-ELECTRONIC CONTROL UNITS

Model ECU-2415

Up to 39 digital, pulse, current measuring feedback and analog inputs along with 24 outputs consisting of up to 24 PWM or digital high-side drivers.

Model ECU-2820

Up to 52 inputs and 28 outputs consisting of up to 24 PWM or digital high-side drivers and up to four digital low-side drivers.



ECU 2415 and 2820

Model ECU-0809

Features 8 flexible sourcing outputs, 9 flexible inputs, and 4 feedback inputs. This controller is built on a powerful 32-bit microprocessor and features a diagnostic indicator, unlimited F-RAM and CAN capability.



ECU 0809

SENSOR VALVES

Select HydraForce valves can be ordered with an integral position sensing option capable of transmitting an on or off signal. This simple sensing solution was designed for interchangeable use with existing HydraForce cartridge valves, is compatible with manual override options and uses an industry standard cavity.

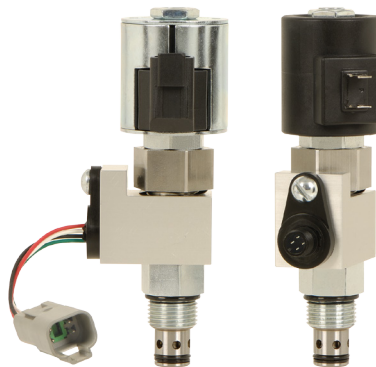

HEAVY DUTY SENSORS

HydraForce has accurate sensors designed for off-road applications.

ERT 120 Temperature Sensor (left)

Our temperature sensor is thermistor style with padded resistors and an output signal between 5427.9 to 436.3 ohms.

ERP Pressure Sensor (right)

Our pressure sensors have 1% total error band accuracy, are IP67 rated.

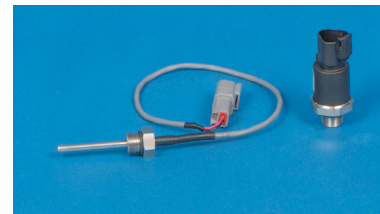

ERP035 – for pressure ranges up to 35 bar (500 psi)

ERP414 – for higher pressures up to 414 bar (6000 psi)

OUR STORY

The HydraForce story began in 1985 when the company was founded near Chicago by several partners who saw the mobile equipment industry's need for quality hydraulic cartridge valves and manifolds delivered in a timely and responsive manner. They also saw the potential for engineering innovation and design flexibility offered by cost-effective and space-saving cartridge valves and hydraulic integrated circuits.

Since its founding, HydraForce continues to be a privately held company as it has grown to several manufacturing locations in North and South America, Europe and Asia, with a network of 120 stocking distributors who can offer local support across the globe.

To maintain our core competency of speed to market, HydraForce has invested in application technical support tools including i-Design, our free hydraulic system design software, which integrates seamlessly with 3rd party simulation software, monthly webinars on new products and application tips, and an online product catalog. All HydraForce products carry a five-year limited warranty against defects in material and workmanship.

OUR QUALITY AND MANUFACTURING GUARANTEE

All three HydraForce plants in North and South America, Europe and Asia follow the same manufacturing processes and standards to ensure global consistency in product quality.

- All products 100% tested
- Use of Lean and Six Sigma practices
- New product introduction tools such as:
 - Advanced Product Quality Planning (APQP)
 - Production Part Approval Process (PPAP)
 - Failure Mode and Effect Analysis (FMEA)
 - Statistical Process Control (SPC)
- Continuous improvement through Kaizen
- Responsive delivery with Kanban throughput system



OUR VISION:
“To be
an independent
provider of
innovative
technical solutions that can
change the
world.”

OUR MISSION:
“To provide our customers
with the highest
quality hydraulic
valves
and the most responsive
customer support
in the world.”



HYDRAFORCE TIMELINE

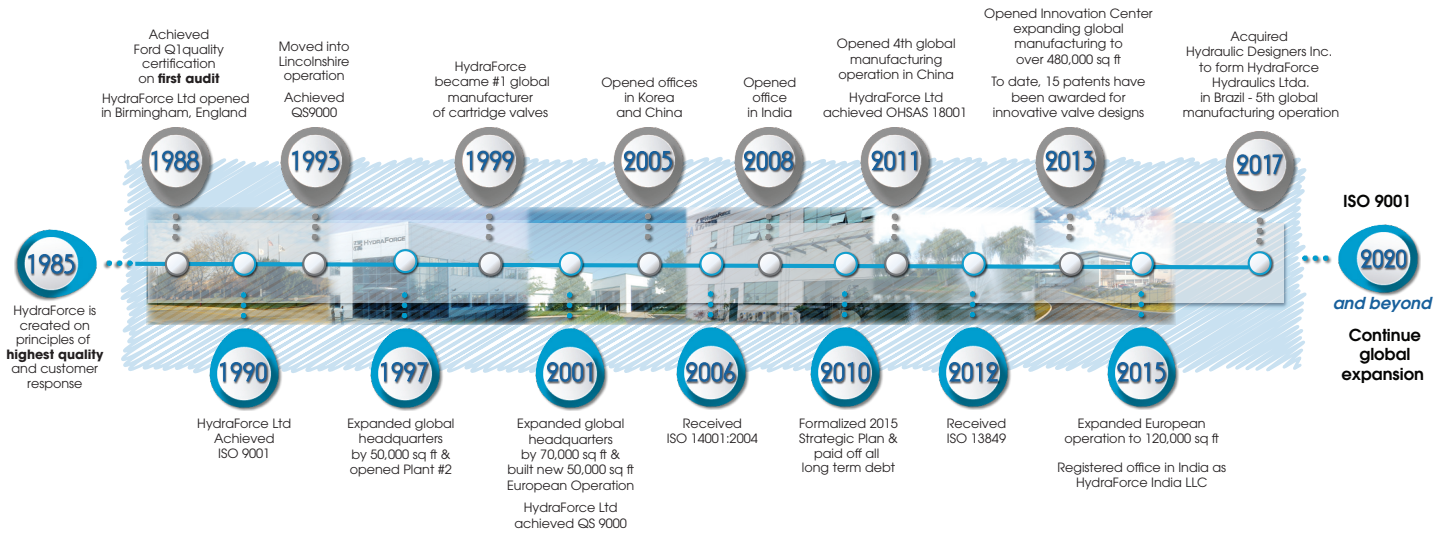

WORLDWIDE SUPPORT

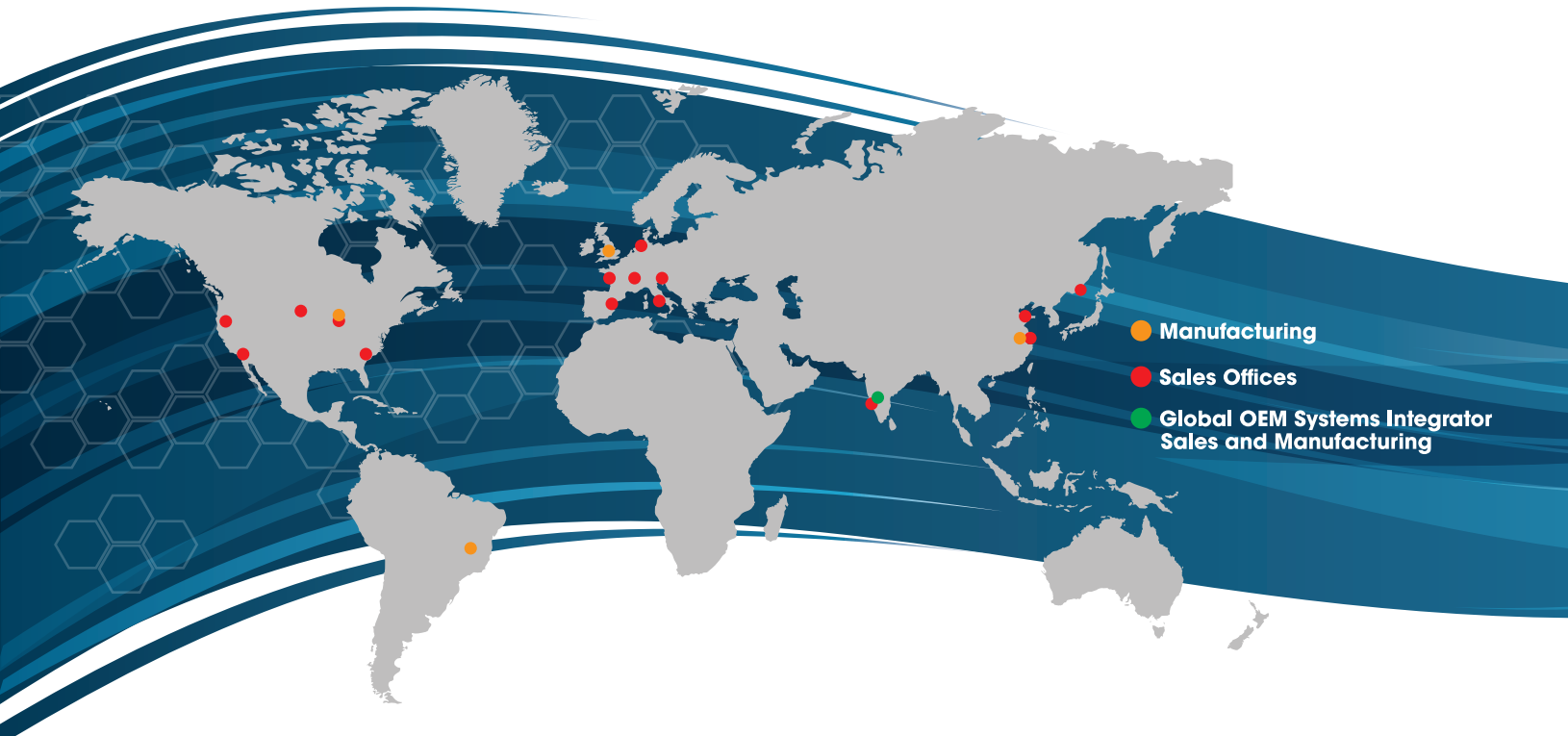

WHY CONSIDER HYDRAFORCE?



- World's largest privately owned cartridge valve manufacturer focused on EH system controls
- Broadest range of cartridge valves
- Designed EH systems for mobile equipment in every industry



- Integrate sensors, fittings, ancillary valves, and other custom components into a single manifold
- Simplified circuit design
- Consolidated or distributed hydraulic systems

- All manifolds are end-of-line function tested
- Use of Lean and Six Sigma practices
- Five year warranty on valves and manifolds



RoHS COMPLIANT HydraForce valve and manifold products comply with the European Council and Parliament RoHS directive 2002/95/EC limiting the use of hazardous substances. For all other products, consult factory.

The content of this document implies no warranty of merchantability or fitness for a particular purpose. This information provides technical illustration only and is not a statement of suitability for any particular application. Each application is unique and we advise you to conduct your own tests and studies to determine the fitness of our products for your application.

© Copyright 2017 HydraForce, Inc. All rights reserved. HydraForce and the HydraForce logo are registered trademarks of HydraForce, Inc.

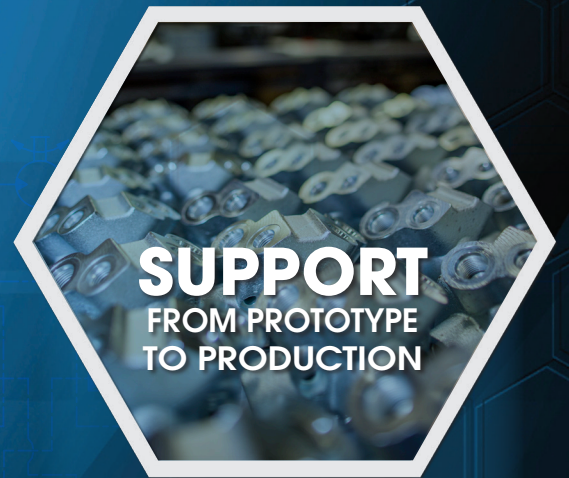

- Free design support
- Simulation software
- Fast prototypes

