

Better performance comes from working together.



HYDRAFORCE
POWER FORWARD

Page 1 of 8

Efficient Electro-Hydraulic (EH) Control Solutions for Off-Highway Transmissions

Working with a specialized, full-line provider of electrohydraulic controls like HydraForce can give the transmission designer an advantage in size, cost, ease of installation, and fuel efficiency. With 28 years of transmission experience, HydraForce has provided numerous customized transmission solutions and is capable of functioning as a full partner in the development of new and improved transmission solutions.

HydraForce provides a full line of contamination-resistant transmission valves that feature IP69K-rated coils and salt-spray resistant plating.

For the transmission market, HydraForce offers the following solutions:

- Pilot-operated proportional clutch solutions
- Direct-acting proportional clutch solutions
- On/Off clutch solutions
- Pressure regulation
- Pressure modulation
- Electronic controllers for clutch engagement, clutch fill and PTO functions
- Highly customizable packaging - block, casting and transmission interface
- Custom valve options available

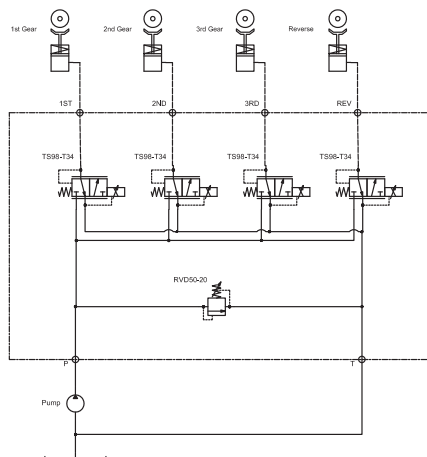

Innovative transmission control solutions for any machine can be quickly configured with the full range of HydraForce electro-hydraulic control options.

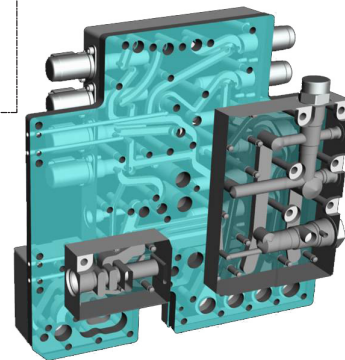

For detailed information and specifications, visit www.hydraforce.com or contact your local HydraForce representative at www.hydraforce.com/distrib/world.htm

HYDRAFORCE, INC.

500 Barclay Blvd. • Lincolnshire, IL 60069 USA
Ph: +1 847 793 2300 • Fx: +1 847 793 0086
Web: www.hydraforce.com • E-Mail: sales@hydraforce.com
ISO 9001 & QS 9000 • Member: National Fluid Power Association

HYDRAFORCE HYDRAULICS, LTD.

Advanced Manufacturing Hub
250 Aston Hall Road • Birmingham B6 7FE • United Kingdom
Ph: +44 121 333 1800 • Fx: +44 121 333 1810
Web: www.hydraforce.com • E-Mail: sales-uk@hydraforce.com
Member: British Fluid Power Association and
Verband Deutscher Maschinen-und Anlagenbau e.V. (VDMA)
ISO 9001 & ISO 14001

HYDRAFORCE HYDRAULIC SYSTEMS (CHANGZHOU) CO., LTD.

388 W. Huanghe Road • Building 15A
GDH Changzhou Airport Indl Park
Xinbei District • Changzhou, China 213022
Ph: +86 519 6988 1200 • Fx: +86 519 6988 1205
Web: www.hydraforce.com • E-Mail: sales@hydraforce.com
ISO 9001: 2008

Transmission control plays a critical role in optimizing performance through all stages of a machine's operating cycle. A good control system can deliver power when it's needed and conserve power when it's not. Speed of response, smooth operation and the ability to deliver a variable pressure for smooth clutch engagement are also the hallmarks of a superior transmission control system.

Smooth clutch engagement results in smoother machine operation, driver comfort, increased fuel efficiency, productivity and longer life for both the clutch and the machine. And of course, controls should be designed to minimize hydraulic leakage in order to optimize fuel efficiency. Among the many control options for transmissions are proportional control with pilot-operated or direct-acting valves, simple on/off control with solenoid valves, and pressure regulation with logic elements that keep the supply of pressure stable despite fluctuations in oil flow.

Pilot-Operated Proportional Clutch Solutions

Two-stage, pilot-operated proportional pressure reducing/relieving valves offer a number of "pluses" for transmission clutch control. These valves consist of a solenoid-driven proportional pilot stage, which controls a main stage reducing/relieving spool function. Pilot-operated valves are available in flow ranges of 30 lpm (8 gpm) to 189 lpm (50 gpm) at pressures from 30 bar (435 psi) to 241 bar (3500 psi).

- Pilot-operated valves are widely available in the ideal flow range needed for transmission control and have low pressure drop at relatively high flows.
- Smaller coil and actuator sizes have lower current draw - less than 1 amp to reach maximum regulated pressure - and lower electrical cost.

Visit www.HydraForce.com for full specifications on these options for transmission control.

Direct-Acting Proportional Clutch Solutions

Single-stage, direct-acting proportional valves are now available with flow ratings comparable to pilot-operated valves. The standard versions of direct-acting valves are capable of 0 to 19 lpm (0 to 5 gpm) and specialized models can now handle flows rates of up to 30 lpm (8 gpm). This provides adequate flow for clutch filling.

- Direct-acting valves have lower leakage rates, which allows the use of a smaller pump. And the use of a smaller pump provides additional reductions in the areas of fuel consumption, exhaust emissions and horsepower losses.
- Shorter main stage stroke and simpler design provides faster response than pilot-operated clutches.
- Direct-acting valves have fewer moving parts which equates to fewer modes of failure and less leakage potential.
- Contamination resistance. Friction disc wear can make transmissions susceptible to contamination and the higher actuator forces of direct-acting valves gives them an ability to "push through" contamination.

PILOT-OPERATED

The TS98-T34 pilot-operated proportional pressure reducing/relieving valve has a flow rating of 34 lpm (9 gpm), pressure drop (reducing) of 5.5 bar (80 psi), de-energized leakage of 550 ml/min and response time of 50 milliseconds.

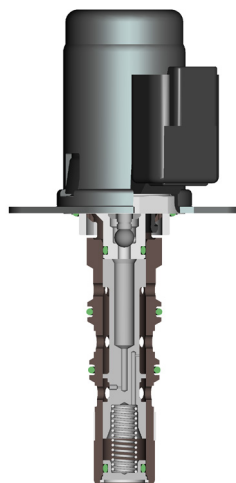
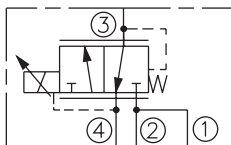

DIRECT-ACTING

The EHPR98 series of direct-acting proportional pressure reducing/relieving valves have flow ratings ranging from 0 to 19 lpm (0 to 5 gpm) for standard models and up to 30 lpm (8 gpm) for specials, de-energized leakage of 50 ml/min, and response time of 30 milliseconds, which is nearly faster than pilot-operated valves.

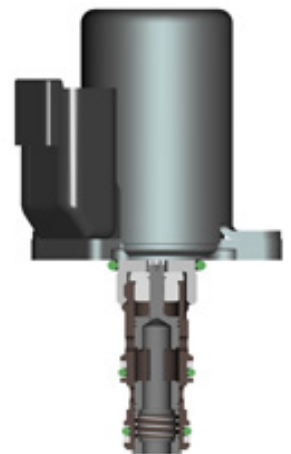
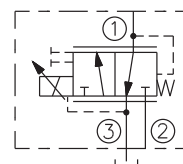

On/Off Clutch Solutions

HydraForce can provide on/off clutch solutions and control of ancillary functions that need to be "on" when the vehicle is in a "stopped" or "ignition-off" condition, such as:

- Four-wheel drive engagement
- Park brake
- Differential lock

SV98-T39 and **SV98-T40** solenoid valves are well-suited for use in specialized low-pressure pilot systems or power shift transmission control. They are economical drop-in style, direct-acting solenoid valves that provide high flow, low pressure drop and low operating pressure. They have IP69-rated, continuous-duty solenoid coils with an corrosion-resistant coating.

Pressure Regulation

HydraForce has the widest variety of pressure regulating solutions, from single cartridge valves to a combination of valves in a custom manifold.

EPxx-S35 logic elements are used specifically in transmission pressure-regulating applications because they provide a relatively flat rate of pressure rise with large fluctuation in oil flow which makes your transmission more efficient. Choose from seven sizes, including several high-pressure models rated at 350 bar. EPxx-S35 valves have flow ratings ranging from 38 lpm for the EP08-S35 up to 379 lpm (100 gpm) for the EP20-S35 and HEP42-S35. A wide range of spring settings, manual override, and corrosion-resistant G-coating options are available.

Pressure Modulation

For applications that need a simple and cost-effective way to modulate pressure, HydraForce offers the TCRV modulating valve. When paired with a cost-effective drop-in solenoid valve, it offers the benefits of proportional control without a complex proportional control algorithm.

TCRV16-20 is a clutch control ramp valve with constant inlet flow. Port 1 is installed in parallel to the clutch. With constant inlet flow at Port 1, the valve will build system pressure according to specified limits.



Custom TCRV modulating valve

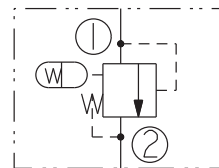

TCRV16-20 Modulating Performance

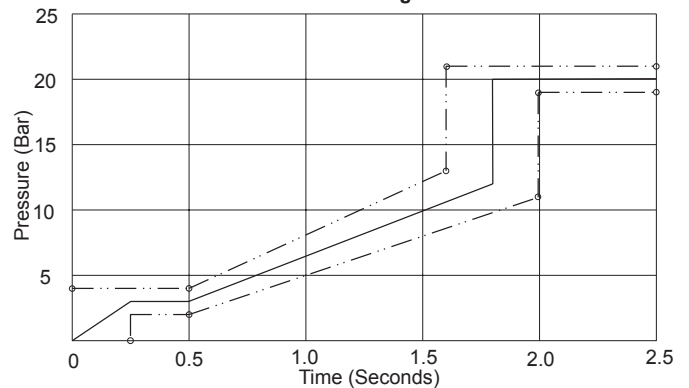

ON/OFF SOLUTIONS

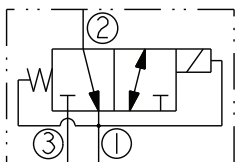

SV98-T39

The **SV98-T39** solenoid valve has a flow rating of 30 lpm (8 gpm), operating pressure of 45 bar (650 psi) and response time of 50 milliseconds.

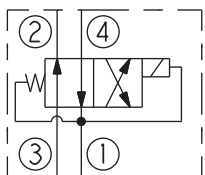
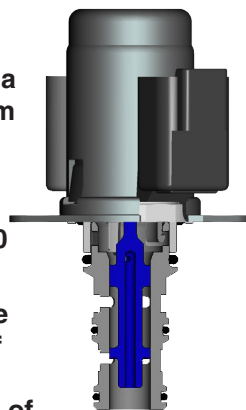

SV98-T40

The **SV98-T40** valve has a flow rating of 30 lpm (8 gpm), operating pressure of 30 bar (435 psi) and response time of 50 milliseconds.

PRESSURE REGULATION

EPxx-S35 logic elements come in seven sizes with flow ratings from 38 lpm up to 379 lpm, operating pressures up to 350 bar and can be ordered with options such as various spring settings, manual override and corrosion-resistant G-coating.

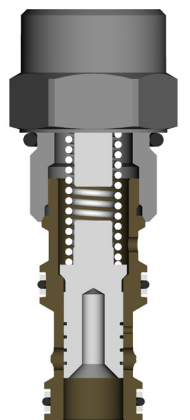
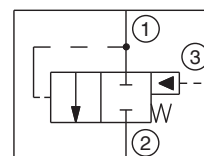

Optimize your machine's powertrain systems and synchronize control of transmission clutch and engine speed with hydraulic cartridge valves.

Hydrostatic Transmission

HydraForce offers many valves that will work in hydrostatic transmission circuits. High pressure check valves (such as the HCVxx-20 line) can be used in charging circuits to inject charge flow into the main loop. Hot shuttles pull oil from the low side of the circuit and feed it into flushing circuits which helps keep the loop oil fresh, filtered, and running at its optimum temperature.

HydraForce also offers an extensive line of relief valves and flow regulators to regulate the pressure and flow of the critical charging and flushing circuits. All of these components are rated to 350 bar with a 10% duty cycle at 420 bar which makes them perfect for hydrostatic applications.



Hydrostatic Transmission

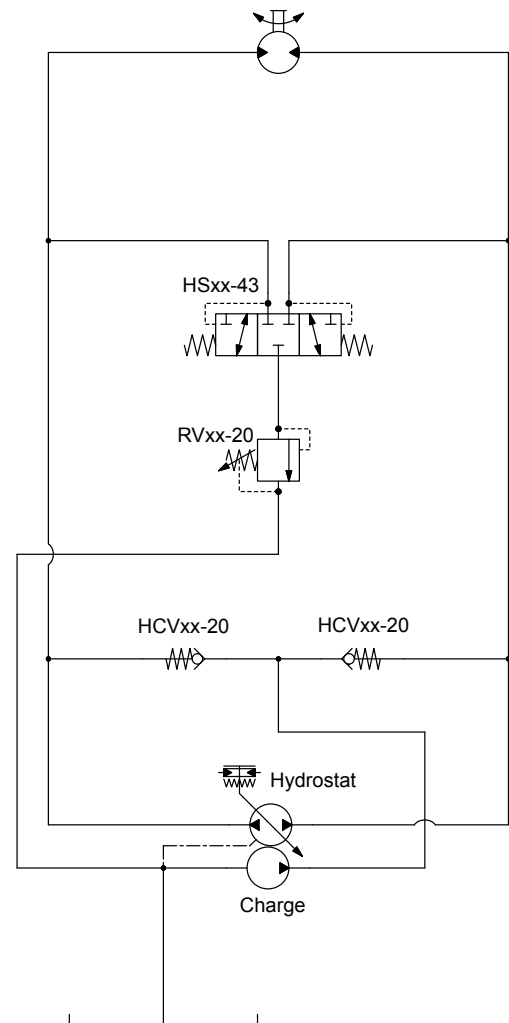

Electronically Controlled Modulation

HydraForce cartridge valves can be paired with an EVDR valve driver to provide electronically controlled modulation of a single speed transmission.

- Forward and reverse
- Modulated fill of the clutch
- Intuitive GUI allows for easy configuration
- Close the loop on throttle or brake pedal
- Inching and trolling functionality built in
- Modulating of forward or reverse clutch control valve

Multi-Speed Transmission

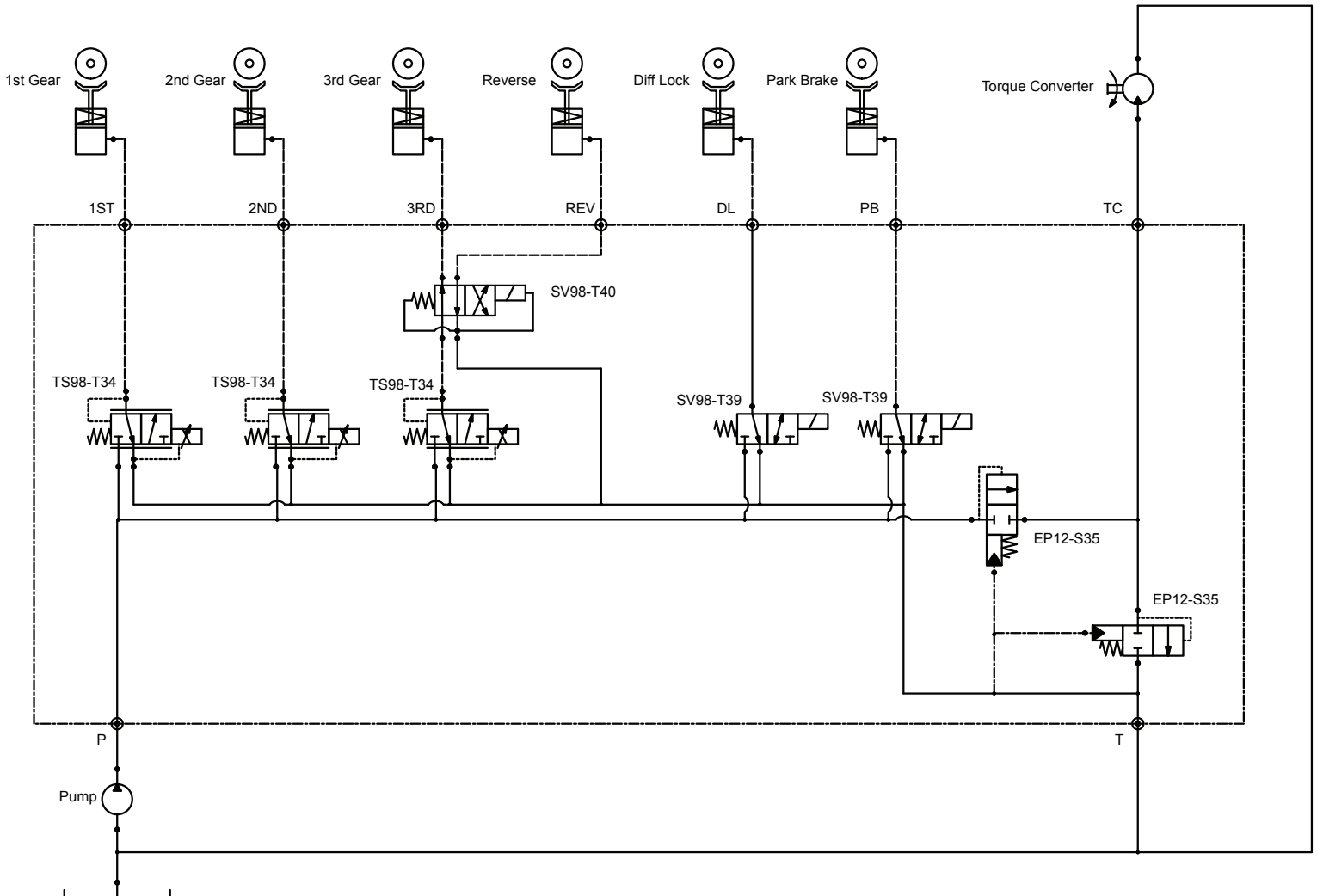

Multi-Speed Transmission

The flexibility of cartridge valving is demonstrated in a multi-speed transmission circuit that provides the full range of control possibilities. On/off clutch control, four-wheel drive and park brake engagement, and gear shifting can all be orchestrated with a mix of electroproportional valves, solenoid valves, and piloted spool-type directional elements.

The EPxx-S35 line of valves are very stable, high flow, pressure regulators used to provide oil to the valves that control the transmission's clutch packs and the torque converter.

The TS98-T34 electro-proportional valve is used to precisely ramp and engage the clutch packs for the smoothest possible shifting experience.

Usually there is a state in transmission gearing when the use of clutches are mutually exclusive. In this example, the 3rd gear and reverse are never engaged at the same time. Here we can use the SV98-T40 to allow a single TS98-T34 to control either clutch pack. This saves money by eliminating a proportional output and valve.

SV98-T39 solenoid valves provide a reliable and cost-effective method for controlling on / off pressure to accessories, such as parking brakes and differential locks.

When you partner with HydraForce, you can utilize the full resources of the largest, independent manufacturer of cartridge valve technology in the world.

Our engineering team specializes in custom applications and uses computerized simulation and analysis software for fast development of the most innovative hydraulic control solutions. With more than 2,000 models of cartridge valves in stock as standard products, there is a large base of parts available to draw upon for custom valve designs to meet any flow or pressure rating.

Computational fluid dynamics (CFD) and finite element analysis (FEA) are used to analyze valve performance and fine-tune designs to meet customer specifications. Once a new design is created, the application engineering team can simulate its performance and rapidly build a prototype for lab or field testing.



HydraForce engineers apply computational fluid dynamics (CFD) to develop custom cartridge valve designs for transmissions and other applications.

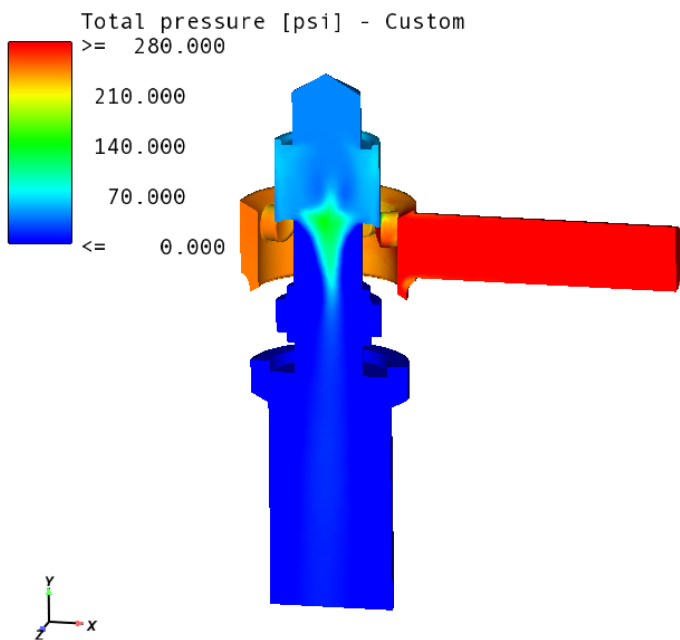

BEFORE - Original CFD image of the EHPR98-T38xx valve shows change in pressure from red to orange.

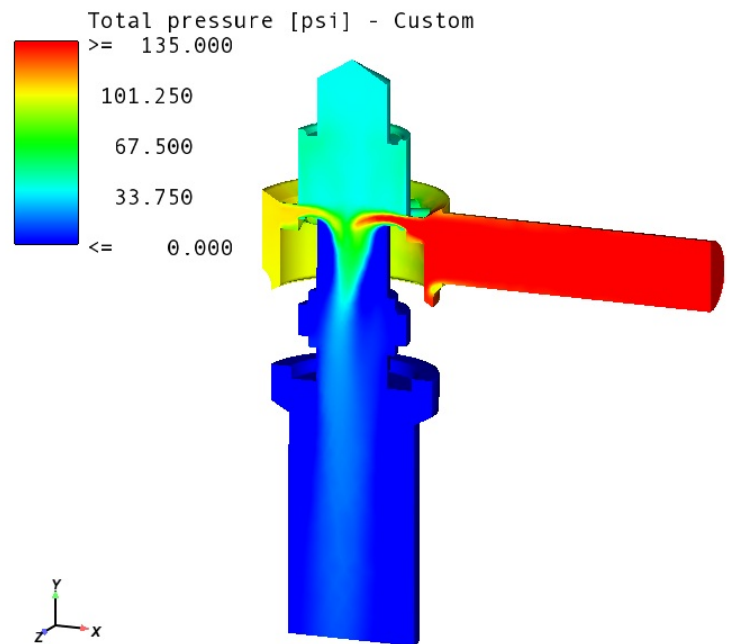

AFTER analysis, improvements made in the valve design reduced pressure drop, as you can see with the color change from orange to yellow.

Innovation and Technology Center Enables Rapid Prototyping

The HydraForce Innovation and Technology Center at 700 Woodlands Parkway in Vernon Hills, Illinois, is the new focal point for virtual and actual testing of hydraulic valves, integrated circuit manifolds and electronic controllers. This 142,000 sq. ft. building houses computer resources for computational fluid dynamics and finite element analysis used in valve design as well as simulation software for hydraulic circuits. There is also an electronics lab for development of electrohydraulic machine controls.

Investments in rapid prototyping machinery have allowed HydraForce to reduce its initial prototype manufacturing lead time by 85%. This ensures the support of prototyping efforts, even during unanticipated product or machinery specification changes. A new high-pressure hydraulic test stand will allow HydraForce to test hydraulic valves and circuits at up to 448 bar (6,500 psi) with flow rates of up to 454 lpm (120 gpm). New valves and manifolds installed on customer equipment can be field-tested on an outdoor proving ground that will be large enough for agricultural, construction and material-handling equipment, including tractors, combines, excavators, wheel loaders and telehandlers.

HydraForce also maintains technical resources for manifold and cartridge valve development at locations in Birmingham, England and Changzhou (near Shanghai), China.

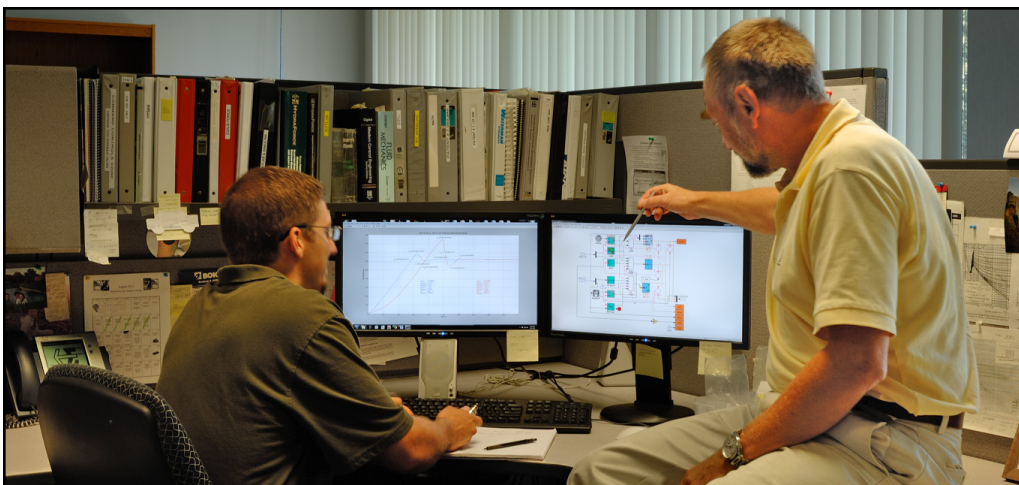
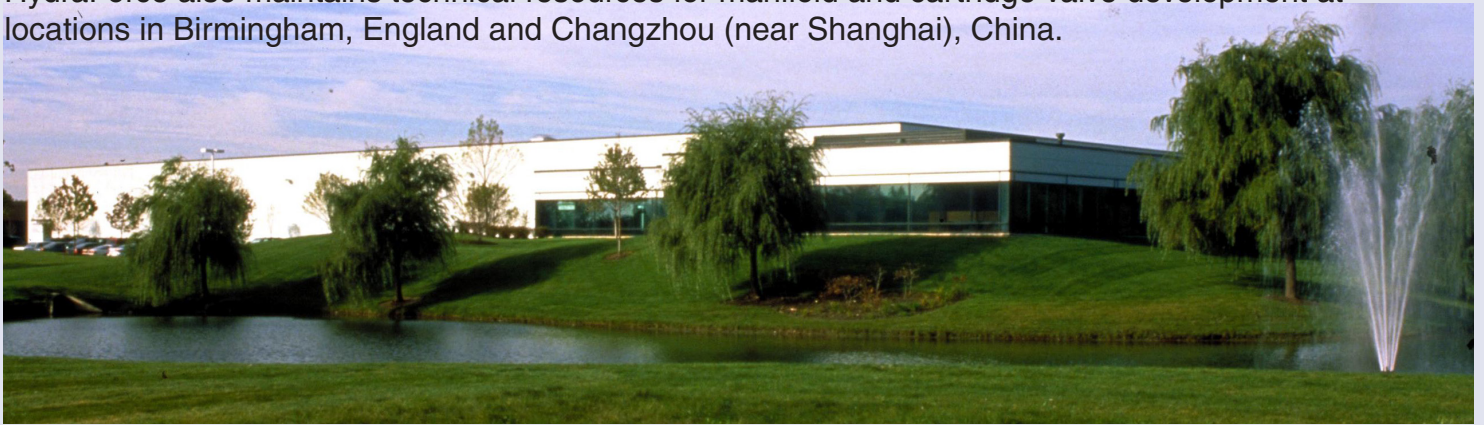

Simulation software allows HydraForce to generate a comparison of the typical pressure response performance of direct-acting and pilot-operated valves for any application.

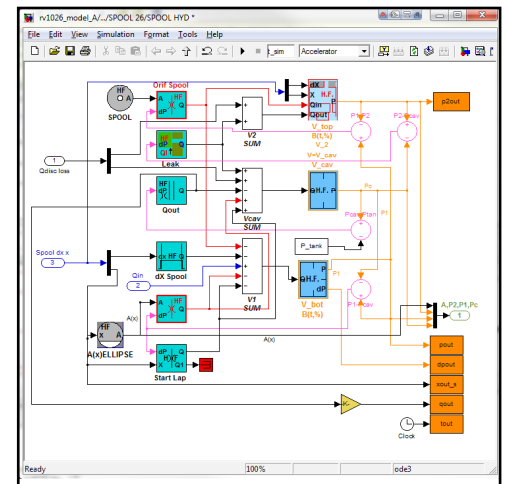

A graphical representation of the mathematical calculations used to analyze the flow of fluid in a valve.

Electronic Control

Synchronize control of transmission clutch, fill, hold, inching and trolling with HydraForce electronic controllers. Our product offering includes program-it-yourself controllers and valve drivers designed especially for use in the off-highway markets.

EVDR-0201

Single or dual output valve driver can control one or two coils to a user-defined and configurable metering profile. Ideal for marine and material-handling applications, it is CAN capable and meets European Commission CE requirements.



ECUs

For multiple inputs and outputs, use an Electronic Control Unit (ECU). HydraForce has ECUs for 20 to 52 inputs and seven to 28 outputs.



SPECIALIZED CONTROLLERS are available for programmable clutch fill, hold and ramp profiles as well as inching and trolling features.

For More Application Ideas . . .

Application engineering assistance is available through your HydraForce distributor or sales representative. They are trained and qualified to assist you with application engineering and technical services for new designs and applications.

For more ideas, you can request a free consultation at <http://info.hydraforce.com/Free-Custom-Circuit-Consultation/>

If you are interested in doing your own circuit, you can download free iDesign hydraulic circuit design software at <http://info.hydraforce.com/download-i-design>

You can also email HydraForce at one of the following addresses:

From the U.S.

sales-us@hydraforce.com

From U.K. and Europe

sales-uk@hydraforce.com

From India

sales-uk@hydraforce.com

From Asia, Africa, Australia, Pacific

sales-intl@hydraforce.com

Corrosion-Resistance at Any Pressure

Transmissions are a demanding application - they run hot and must perform in extreme temperatures, they're running all the time, are sensitive to pressure drop and low battery charge, and are located on the chassis where they are exposed to the elements and are vulnerable to corrosion. HydraForce has two answers to the corrosion issue.

1. All HydraForce environmental E-coils are now rated to endure 1000 hours of salt spray per ASTM standard B117. When you specify HydraForce, you automatically get this protection at no extra charge.
2. All HydraForce standard products can now be ordered with a protective, corrosion-resistant G-coating that guards against corrosion. To order, use the G prefix on the HydraForce model code.