

SEZIONE A-A

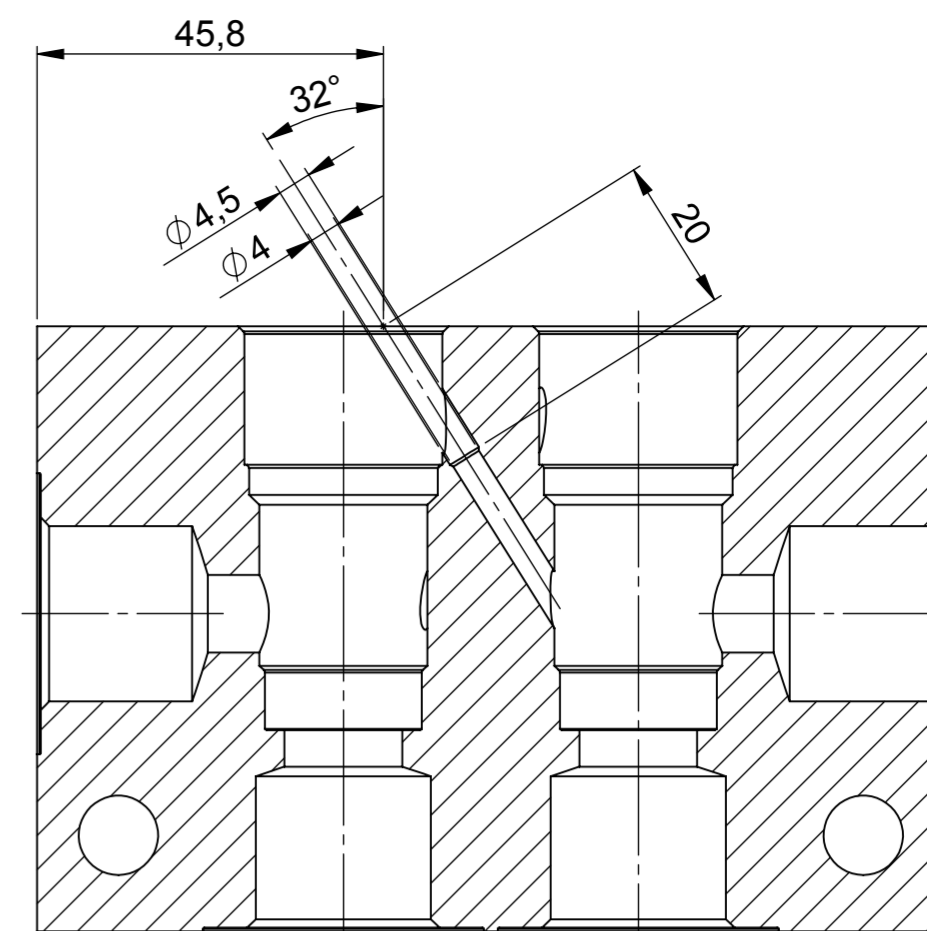

SEZIONE B-B

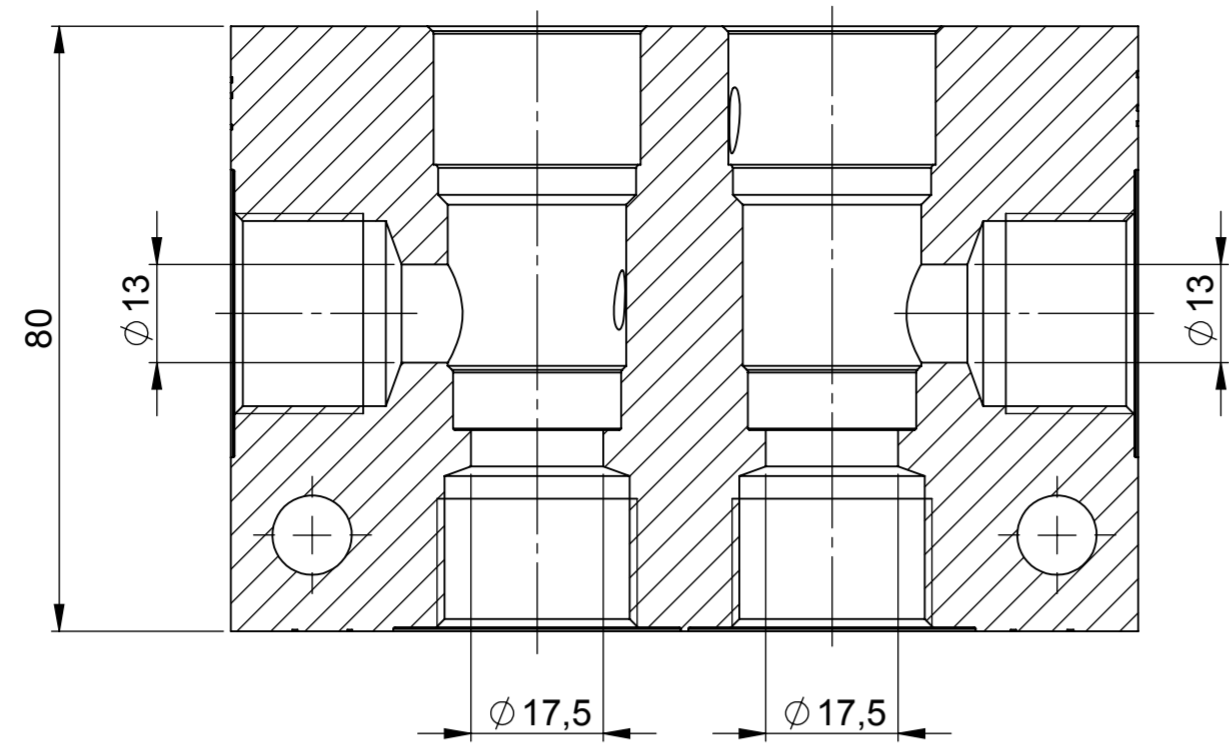
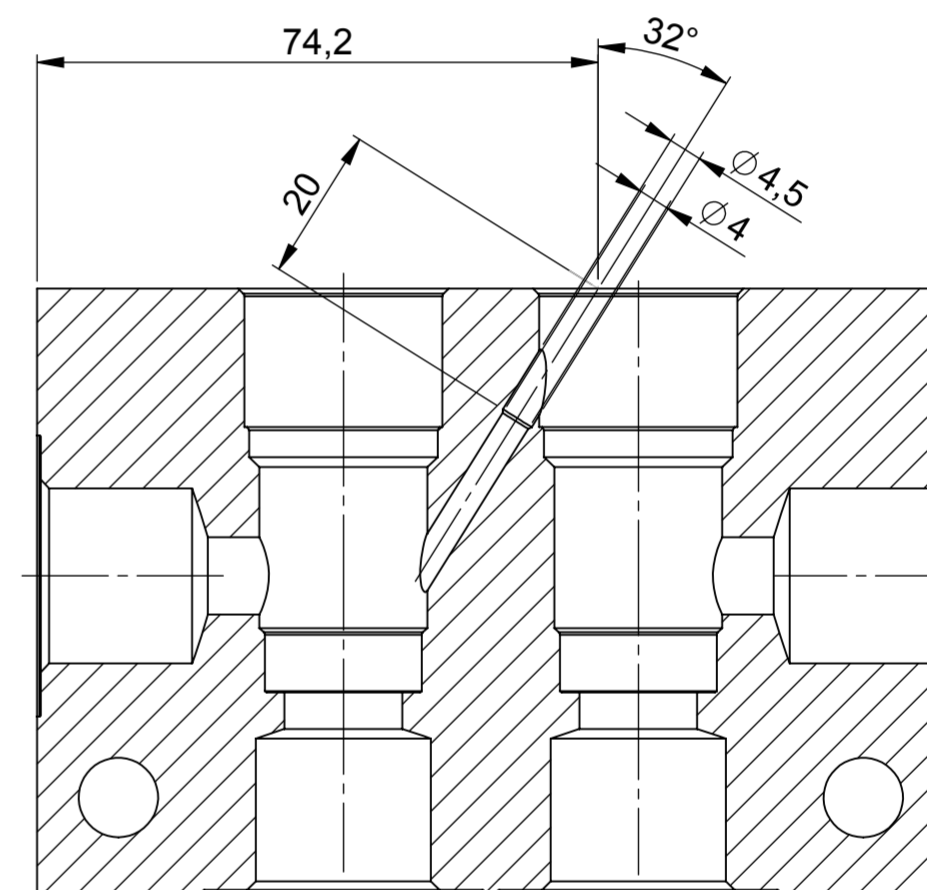

SEZIONE C-C

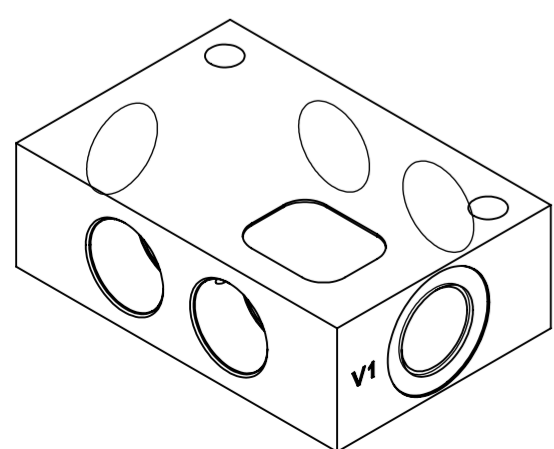
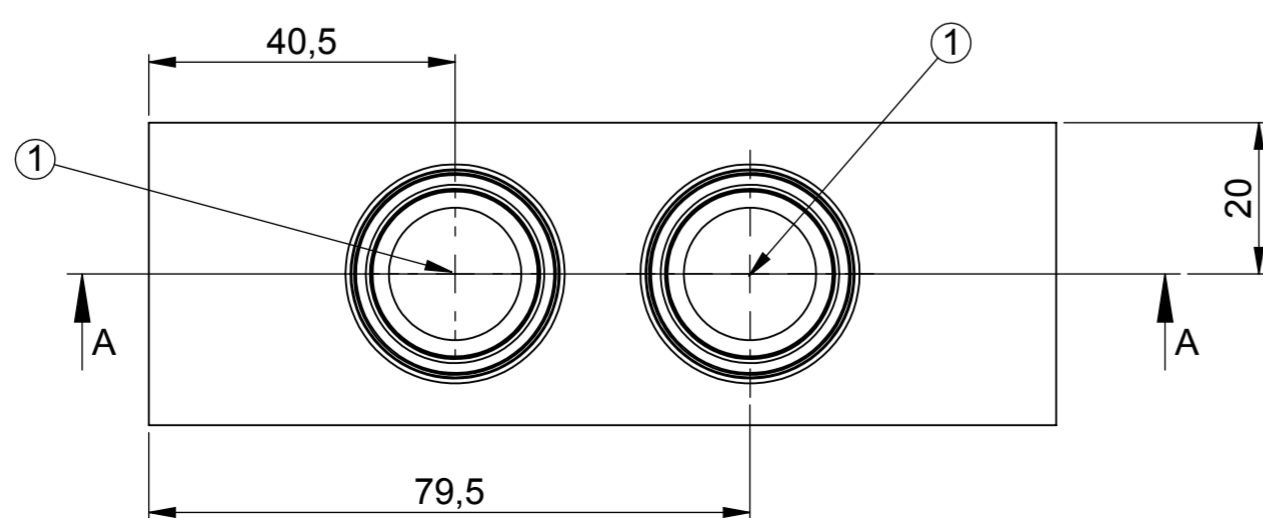
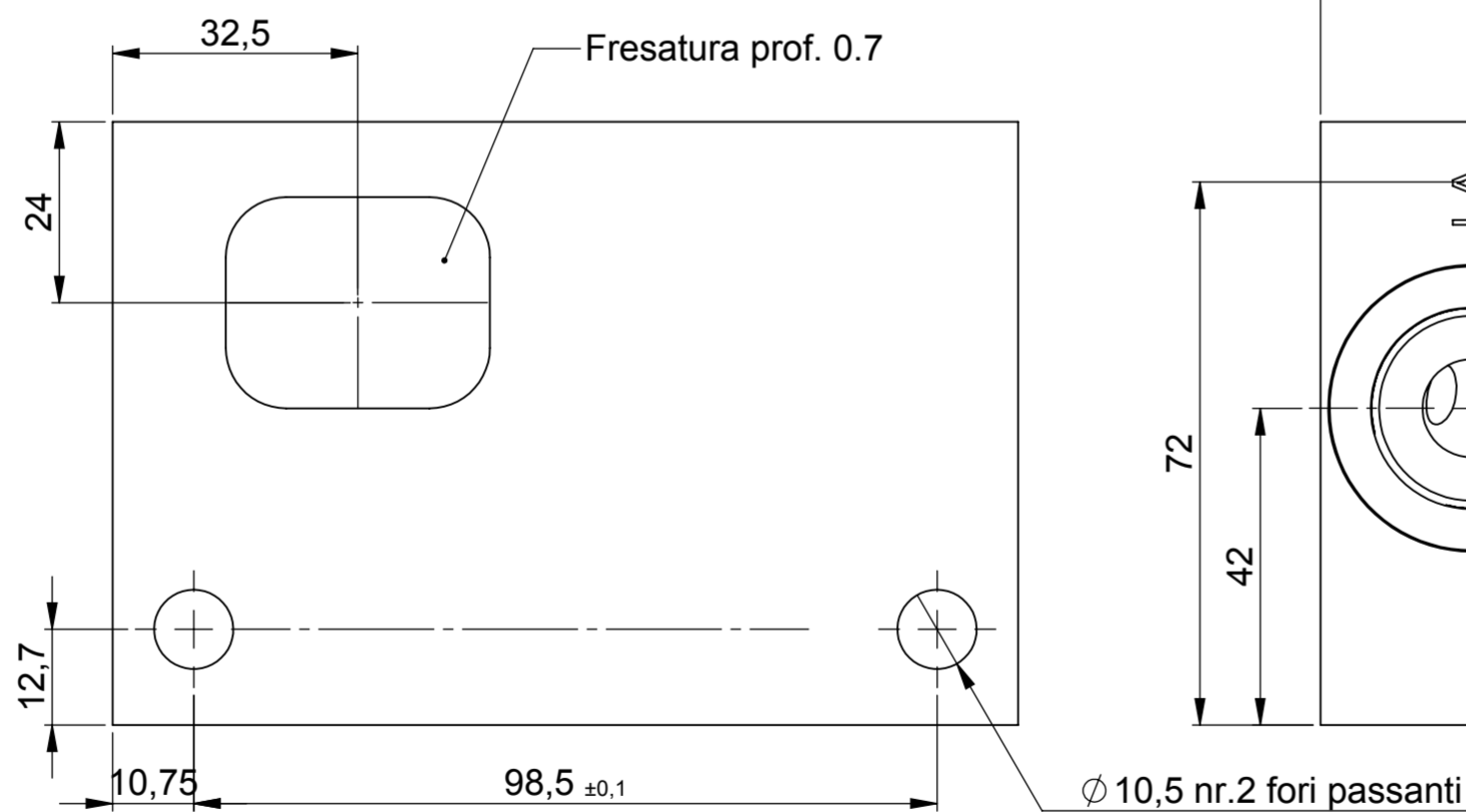
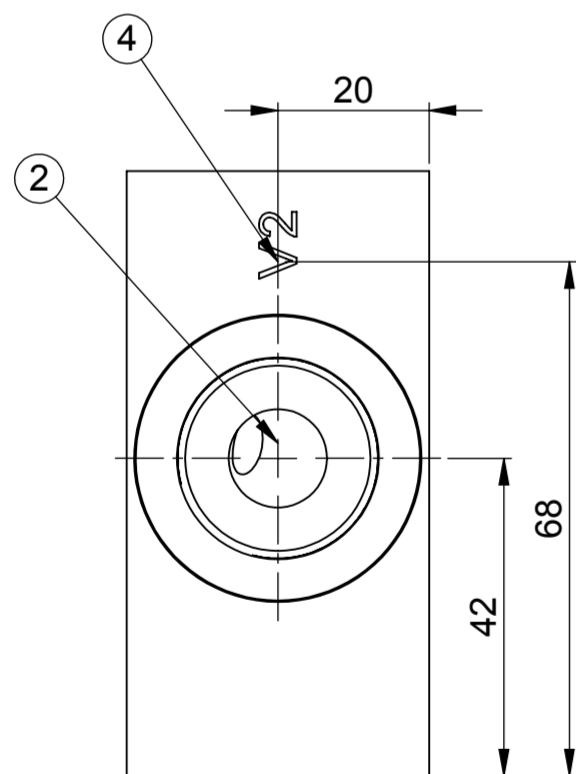
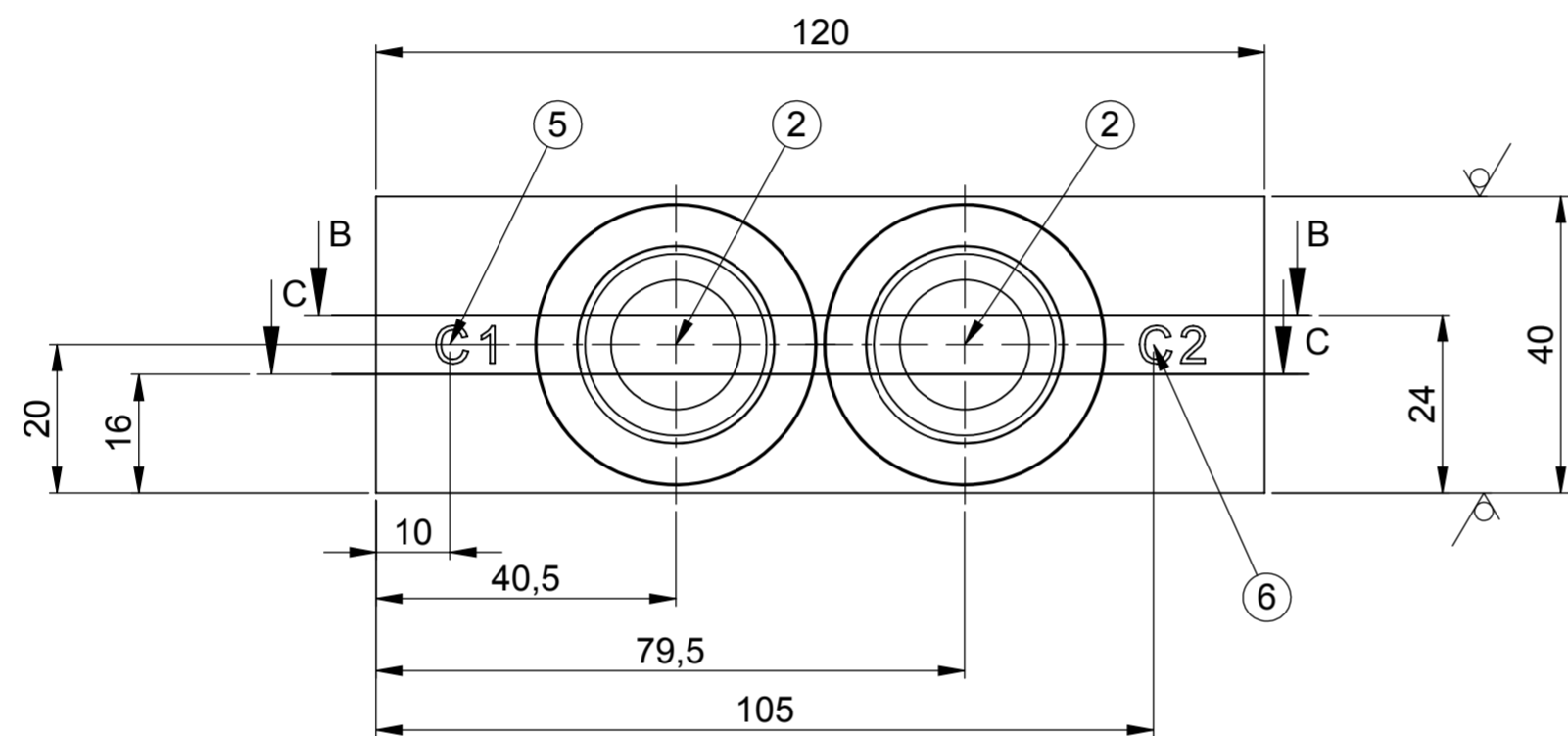

Profondità lamature (tutte) = 0.5

Ra 3.2 (✓)

TABELLA FORI			
Pos.	Codice	Q.tà	Descrizione
1	CACMSUN00011413	2	CAVITA' 3V 1"-14 UNS-2B (SUN T-2A)
2	VI001G340000000	4	ATTACCO G 3/4 ISO 1179-1
3	VI0150000000003	1	MARCATURA V1
4	VI0150000000004	1	MARCATURA V2
5	VI0150000000012	1	MARCATURA C1
6	VI0150000000013	1	MARCATURA C2

UNLESS OTHERWISE SPECIFIED

DIMENSIONS mm

TOLERANCES ACCORDING TO (ISO2768-mk)

BASE SHAFT (h13)

BASE HOLE (H13)

LINEAR DIMENSIONS TILL (0.5 +/- 0.05)

ANGULAR DIMENSIONS TILL (0.5 +/- 0.05)

FILLETS AND CHAMFERS TILL (0.5 +/- 0.05)

DEBUR AND BREAK SHARP EDGES (0.1 +/- 0.05)

TITLE

C NORMALE T2A 4:1 TV 3/4

MATERIAL HEAT TREATMENTS SURFACE TREATMENTS HARDNESS

11SMn37 UNI EN 10277-3 (1.0736)

VI500-S

SCALE	WEIGHT	REVISIONS	
1:1	2.174		
DRAWING BY	DATE	REPLACES DRW. N.	DRAWING N.
Pedata	09/08/17		COAVP1000000301

REVISIONS DESCRIPTIONS

Blocchetto	
INGOMBRO	Valore
H	120
L	40
P	80