

SEZIONE B-B

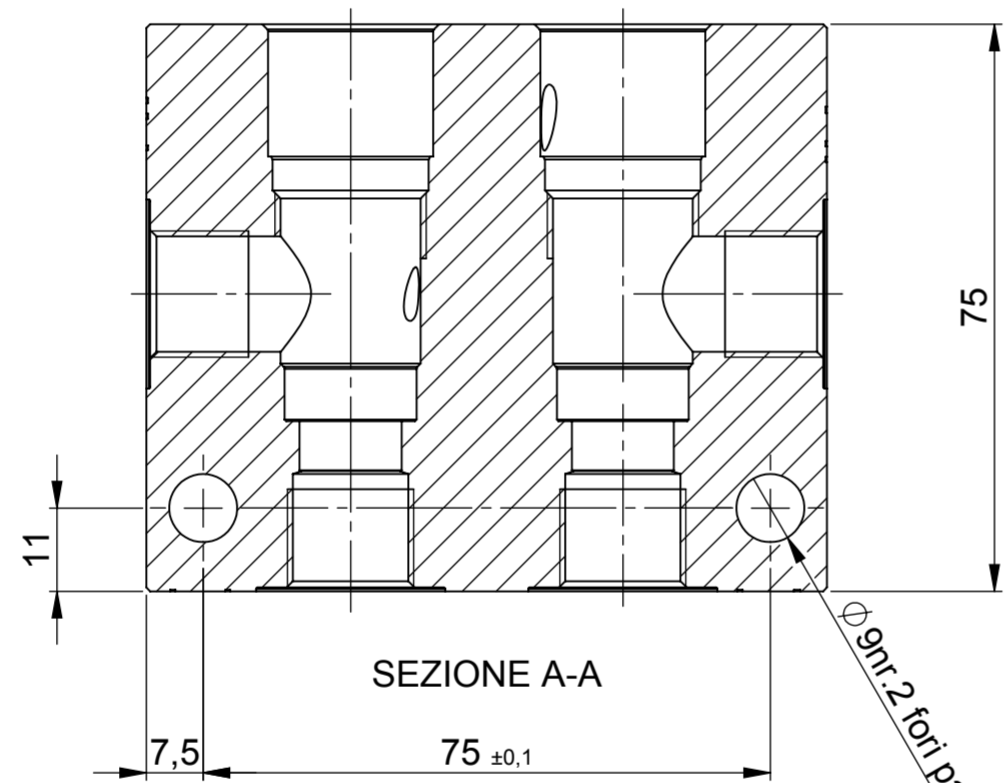

SEZIONE A-A

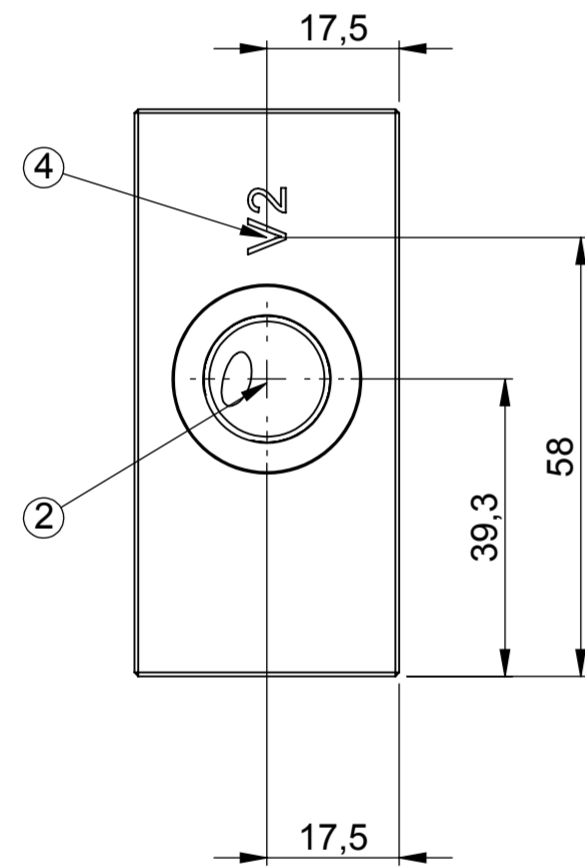
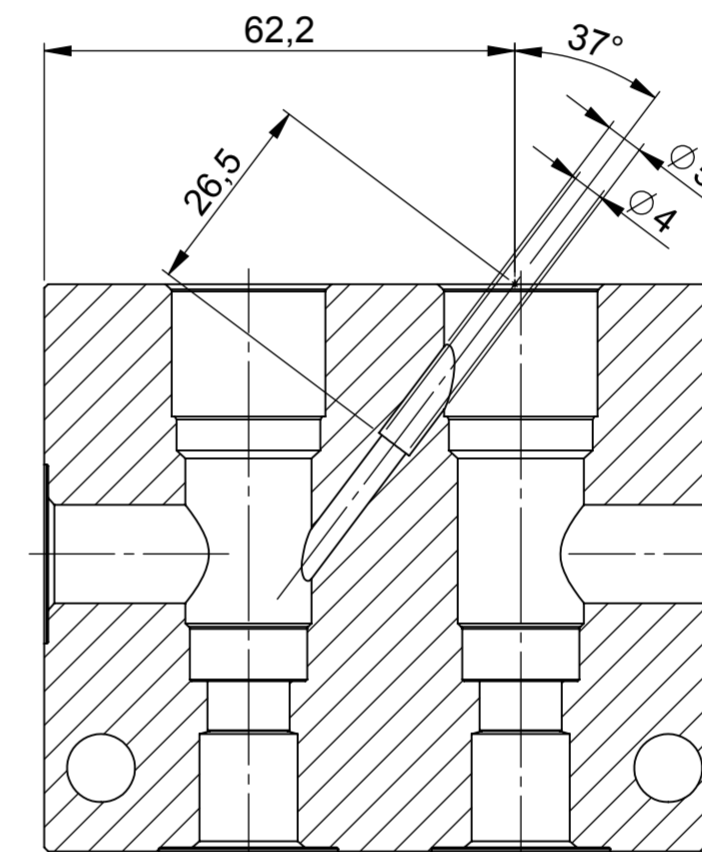
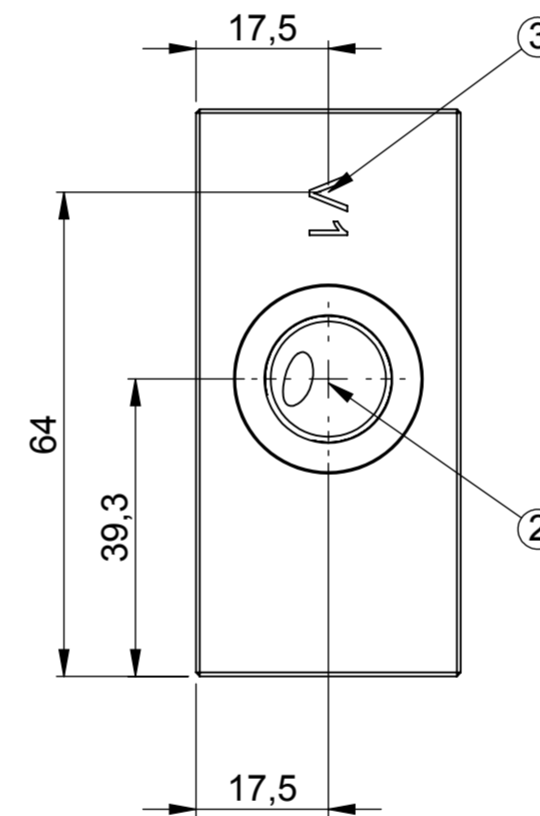

SEZIONE C-C

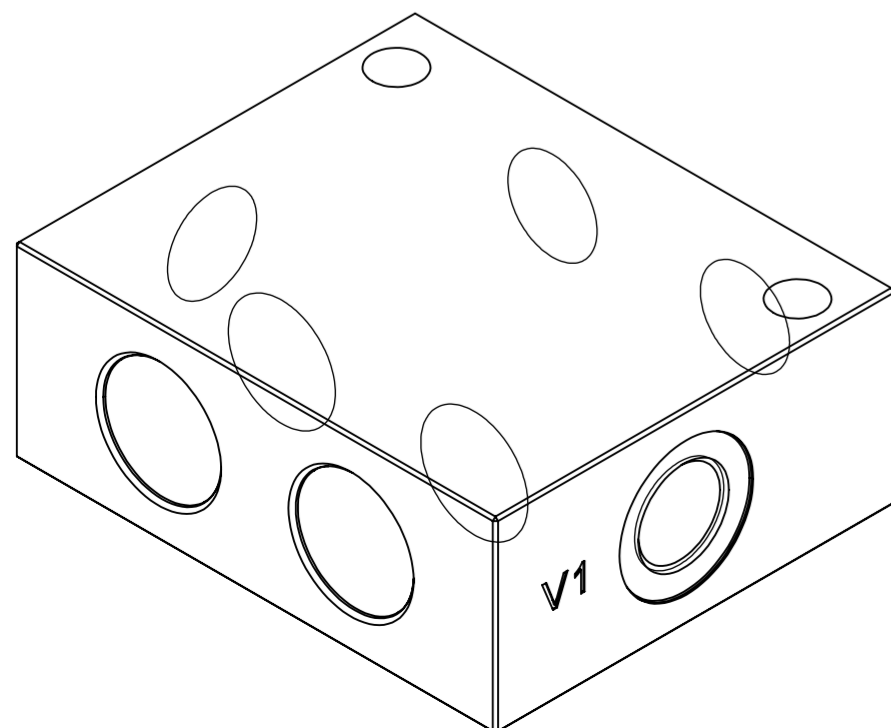
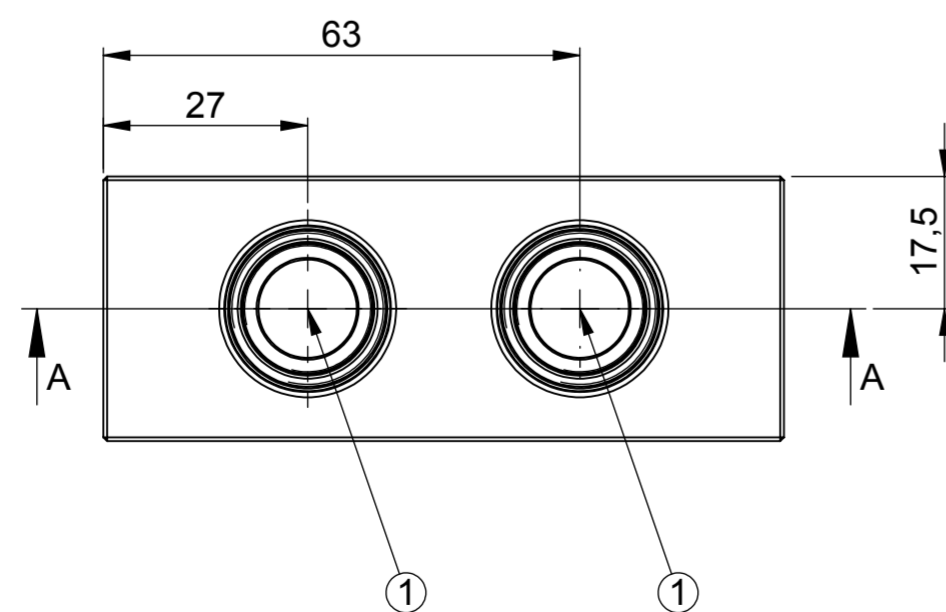

Nota: profondità lamatura attacchi VI001G380000000 accettabile : min.0.2/max 0.8

| TABELLA FORI |                 |      |                                |
|--------------|-----------------|------|--------------------------------|
| Pos.         | Codice          | Q.tà | Descrizione                    |
| 1            | CACMSUNM20X1515 | 2    | CAVITA' 3V M20X1.5 (SUN T-11A) |
| 2            | VI001G380000000 | 4    | ATTACCO 3/8 BSPP ISO1179-1     |
| 3            | VI0150000000003 | 1    | MARCATURA V1                   |
| 4            | VI0150000000004 | 1    | MARCATURA V2                   |
| 5            | VI0150000000012 | 1    | MARCATURA C1                   |
| 6            | VI0150000000013 | 1    | MARCATURA C2                   |

UNLESS OTHERWISE SPECIFIED

DIMENSIONS mm ANGLE PROJECTION

TOLERANCES ACCORDING TO (ISO2768-mk)

BASE SHAFT (h13)

BASE HOLE (H13)

LINEAR DIMENSIONS TILL (0.5 +/- 0.05)

ANGULAR DIMENSIONS TILL (0.5 +/- 0.05)

FILLETS AND CHAMFERS TILL (0.5 +/- 0.05)

DEBUR AND BREAK SHARP EDGES (0.1 +/- 0.05)

TITLE

C NORMALE RISTRETTA T11A 3:1 SP L 382

MATERIAL HEAT TREATMENTS SURFACE TREATMENTS HARDNESS

11SMn37 UNI EN 10277-3 (1.0736)

VI500-S

| SCALE      | WEIGHT   | REVISIONS        |                 |
|------------|----------|------------------|-----------------|
| 1:1        | 1.440    |                  |                 |
| DRAWING BY | DATE     | REPLACES DRW. N. | DRAWING N.      |
| Pedata     | 05/10/17 |                  | COAVP1000000317 |

PROPRIETARY AND CONFIDENTIAL THE INFORMATION CONTAINED IN THIS DRAWING IS THE SOLE PROPERTY OF VALVOLE ITALIA. NO REPRODUCTION IN PART OR AS A WHOLE WITHOUT THE WRITTEN PERMISSION OF VALVOLE ITALIA. NO IS FORBIDDEN.

Ra 3.2 ( )

REVISIONS DESCRIPTIONS